

RUSSIAN MARITIME REGISTER OF SHIPPING

RULES
FOR THE CLASSIFICATION
AND CONSTRUCTION
OF SEA-GOING SHIPS

PART X
BOILERS, HEAT EXCHANGERS
AND PRESSURE VESSELS



Saint-Petersburg
Edition 2018

Rules for the Classification and Construction of Sea-Going Ships of Russian Maritime Register of Shipping have been approved in accordance with the established approval procedure and come into force on 1 January 2018.

The present edition of the Rules is based on the 2017 edition taking into account the amendments developed immediately before publication.

The unified requirements, interpretations and recommendations of the International Association of Classification Societies (IACS) and the relevant resolutions of the International Maritime Organization (IMO) have been taken into consideration.

The Rules are published in the following parts:

Part I "Classification";

Part II "Hull";

Part III "Equipment, Arrangements and Outfit";

Part IV "Stability";

Part V "Subdivision";

Part VI "Fire Protection";

Part VII "Machinery Installations";

Part VIII "Systems and Piping";

Part IX "Machinery";

Part X "Boilers, Heat Exchangers and Pressure Vessels";

Part XI "Electrical Equipment";

Part XII "Refrigerating Plants";

Part XIII "Materials";

Part XIV "Welding";

Part XV "Automation";

Part XVI "Hull Structure and Strength of Glass-Reinforced Plastic Ships and Boats";

Part XVII "Distinguishing Marks and Descriptive Notations in the Class Notation Specifying Structural and Operational Particulars of Ships";

Part XVIII "Common Structural Rules for Bulk Carriers and Oil Tankers". The text of the Part is identical to that of the IACS Common Structural Rules;

Part XIX "Additional Requirements for Structures of Container Ships and Ships, Dedicated Primarily to Carry their Load in Containers". The text of the Part is identical to IACS UR S11A "Longitudinal Strength Standard for Container Ships" (June 2015) and S34 "Functional Requirements on Load Cases for Strength Assessment of Container Ships by Finite Element Analysis" (May 2015).

Parts I to XVII are published in electronic format and hard copy in Russian and English. In case of discrepancies between the Russian and English versions, the Russian version shall prevail.

Parts XVIII to XIX are published in English and in electronic format only.

As compared to the 2017 edition, the present edition of the Rules contains the following amendments.

RULES FOR THE CLASSIFICATION AND CONSTRUCTION OF SEA-GOING SHIPS

PART X. BOILERS, HEAT EXCHANGERS AND PRESSURE VESSELS

1. Paras 1.4.5, 1.4.8, 1.5.2, 2.1.1.2, 2.1.4.5, 2.1.6.6, 2.1.6.8, 2.4.1.2, 2.5.3, 2.9.1.3, 3.3.4.3, 3.5.9, 6.1.2, 6.4.4.5 and 6.4.4.8: the requirements have been specified to avoid the ambiguous phrases "special consideration".
2. Paras 1.5.3, 2.6.7, 2.9.1.4, 6.1.4 have been deleted to avoid the ambiguous phrase "special consideration".
3. Para 2.5.3: the requirements have been specified.
4. Chapter 2.6: para 2.6.7 has been deleted, subsequent para 2.6.8 has been renumbered 2.6.7 accordingly;
5. Chapter 2.9: para 2.9.1.4 has been deleted subsequent paras 2.9.1.5 and 2.9.1.6 have been renumbered 2.9.1.4 and 2.9.1.5 accordingly;
new para 2.9.1.4: the requirements have been specified.
6. Editorial amendments have been made.

CONTENTS

PART X. BOILERS, HEAT EXCHANGERS AND PRESSURE VESSELS

1	General	5	3.4	Incinerator boilers	33	
1.1	Application	5	3.5	Thermal liquid boilers	34	
1.2	Definitions and explanations	5	4	Controls, governors, protective devices and alarms for boilers	36	
1.3	Scope of surveys	5	4.1	General	36	
1.4	Materials	7	4.2	Governors and controls	36	
1.5	Welding	8	4.3	Protective devices	36	
1.6	Heat treatment	8	4.4	Alarms	36	
1.7	Tests	8	5	Oil burner units of boilers	37	
1.8	Boiler rooms and spare parts	8	5.1	General	37	
2	Strength calculations	10	5.2	Burners	37	
2.1	General	10	5.3	Automatic burner units	37	
2.2	Cylindrical and spherical elements and tubes	15	6	Heat exchangers and pressure vessels	39	
2.3	Conical elements	17	6.1	General	39	
2.4	Flat walls, end plates and covers	18	6.2	Construction requirements	39	
2.5	Tube plates	20	6.3	Valves and gauges	39	
2.6	Dished ends	21	6.4	Special requirements for heat exchangers and pressure vessels	40	
2.7	Flanged end plates	22	7	Strength characteristics of boiler steel	42	
2.8	Headers of rectangular section	23	7.1	Lower yield stress as a function of design temperature, MPa	42	
2.9	Reinforcement of openings in cylindrical, spherical, conical walls and in dished ends	23	7.2	Average stress to produce rupture in 100 000 hours as a function of design temperature, MPa	42	
2.10	Stays	27	Appendix. Typical examples of allowable welded joints for boilers, heat exchangers and pressure vessels			43
2.11	Top girders	28				
3	Boilers	29				
3.1	General	29				
3.2	Construction requirements	29				
3.3	Valves and gauges	30				

PART X. BOILERS, HEAT EXCHANGERS AND PRESSURE VESSELS

1 GENERAL

1.1 APPLICATION

1.1.1 The requirements of the present Part of the Rules apply to boilers, heat exchangers and pressure vessels, excluding:

- .1 water heating boilers (not mentioned in 1.3.2.1 and 1.3.2.3);
- .2 manned submersibles and diving systems as regards the construction and strength of their pressure hulls;
- .3 non-stationary standard liquefied gas cylinders (refer to 1.3.2.4);
- .4 assemblies and components of units that are not self-contained pressure vessels;
- .5 units comprising pressure pipe systems and installed outside boilers, heat exchangers or pressure vessels;
- .6 air coolers designed to operate at a working pressure less than 0,1 MPa in the air space;
- .7 heat exchangers and vessels subjected exclusively to liquid pressure (not mentioned in 1.3.2.1 and 1.3.2.3).

1.1.2 The requirements of the present Part also apply to oil burner units of boilers.

1.2 DEFINITIONS AND EXPLANATIONS

1.2.1 The definitions and explanations relating to general terminology of the Rules are given in Part I "Classification".

For the purpose of the present Part the following definitions have been adopted.

Automatic boiler oil burner unit is a device for combustion of fuel oil, the operation of which is controlled automatically, without any direct attendance of the operating personnel.

Auxiliary boilers for essential services are boilers, which supply steam to the auxiliary machinery, systems and equipment providing propulsion of the ship, safety of navigation and proper carriage of goods, if no other sources of power being available on board the ship for operating the said machinery, equipment and systems in case the boilers fail to operate.

Water heating boiler is a ship's boiler heating water or water-base liquid systems (e.g.ethylene glycol solution in water) of appropriate temperature.

Steam boiler is a ship's boiler generating steam of appropriate steam conditions.

Working pressure is the maximum permissible pressure under normal conditions on continuous running, excluding permissible short-time pressure rises, such as may be occasioned by the operation of a safety valve or other protective devices.

Design boiler capacity is the maximum amount of steam that can be generated by the boiler at design parameters during 1 h on continuous running.

Design wall temperature is the average wall thickness temperature used in calculation of allowable stresses in dependence upon the temperature of the medium and the heating conditions.

Design pressure is the pressure used in strength calculations.

Walls of boilers, heat exchangers and pressure vessels are the walls of steam and water (gas and liquid) spaces as well as the walls of branch pipes up to the stop valves and the walls of stop valve bodies.

1.3 SCOPE OF SURVEYS

1.3.1 General.

1.3.1.1 The general provisions relating to procedure of classification, survey during construction and in service are given in the General Regulations for the Classification and Other Activity and in Part I "Classification".

1.3.1.2 Boilers, heat exchangers and pressure vessels are classified in accordance with Table 1.3.1.2 depending on the parameters and design features.

Table 1.3.1.2

Item	Class		
	I	II	III
Boilers including waste-heat boilers and water heating boilers designed for water temperature above 115 °C, steam superheaters and steam headers	$p > 0,35$	$p \leq 0,35$	—
Thermal liquid boilers, pressure vessels and heat exchangers with toxic, inflammable or explosive working medium	Any parameters	—	—
Pressure vessels and heat exchangers	$p > 4$ or $t > 350$ and $s > 35$	$1,6 < p \leq 4$ or $120 < t \leq 350$ and $16 < s \leq 35$	$p \leq 1,6$ and $t \leq 120$ and $s \leq 16$
Symbols: p = design pressure, in MPa; t = design wall temperature, in °C; s = wall thickness, in mm.			

1.3.1.3 Boilers and heat exchangers of Class I and II shall be produced by manufacturers having the Recognition Certificate of the Register.

1.3.2 Scope of surveys.

1.3.2.1 Subject to survey by the Register in the process of construction are:

.1 steam boilers (including waste-heat boilers), steam superheaters and economizers operating at working pressure of 0,07 MPa and upwards;

.2 thermal liquid boilers (with organic working medium), including waste-heat boilers;

.3 heat exchangers and vessels, which under operating conditions are filled fully or partially with gas or vapour at working pressure of 0,07 MPa and over, and which have a capacity of 0,025 m³ and over, or with the product of pressure, in MPa, by capacity, in m³, being 0,03 MPa·m³ and upwards;

.4 desalinating plants;

.5 condensers of main and auxiliary machinery;

.6 oil burning equipment;

.7 water heating boilers designed for water temperatures above 115 °C;

.8 coolers, heaters and filters of fuel and lubricating oil and water for main and auxiliary engines;

.9 automatic devices for control of salinity of boiler feed water;

.10 incinerator boilers.

1.3.2.2 Exempt from the survey by the Register in the process of construction are the heat exchangers and pressure vessels indicated in 1.1.1.2 and 1.1.1.6.

1.3.2.3 Water heating boilers designed for water temperatures above 115 °C shall comply, as regards the materials used and scantlings of elements, with the requirements for steam boilers specified in the present Part.

Filters and coolers of main and auxiliary machinery shall comply, as regards the materials used and scantlings of elements, with the requirements for heat exchangers and pressure vessels specified in the present Part.

1.3.2.4 Cylinders designed for storage of compressed gases and used in various systems and units for the purposes of ship's operation may be manufactured to the current standards under the supervision of a competent technical supervision body.

1.3.2.5 The scope of survey of the heat exchangers and pressure vessels incorporated into refrigerating plants is specified in 1.1.3, 1.3.2 and 1.3.3, Part XII "Refrigerating Plants".

1.3.3 Components subject to survey.

The components specified in Table 1.3.3 are subject to survey by the Register during manufacture according to the technical documentation approved by the Register, the list of which is given in 1.3.4.

1.3.4 Technical documentation.

1.3.4.1 The following technical documentation shall be submitted to the Register before manufacture of boilers, heat exchangers and pressure vessels is commenced:

.1 construction drawings with sections and descriptions, giving all necessary data for checking the calculations and structures (scantlings, materials, electrodes, location and dimensions of weld seams, fastenings, heat treatment methods to be used, etc.);

Table 1.3.3

Nos	Components of boilers, heat exchangers and pressure vessels	Material	Chapter of Part XIII "Materials"
1	Boilers, steam superheaters, economizers and steam-heated steam generators		
1.1	Shells, end plates, tube plates, drums, headers and chambers	Rolled steel	3.3
1.2	Heated and non-heated tubes	Seamless steel	3.4
1.3	Furnaces and elements of combustion chambers	Rolled steel	3.3
1.4	Girders, long and short stays	Forged steel	3.7
		Rolled steel	3.3
1.5	Bodies of valves for pressure of 0,7 MPa and over	Forged steel	3.7
		Cast steel	3.8
		Cast iron	3.9
		Copper alloys	4.1
2	Heat exchangers and pressure vessels		
2.1	Shells, distributors, end plates, headers and covers	Forged steel	3.7
		Rolled steel	3.3
		Cast steel	3.8
		Copper alloys	4.1
		Cast iron	3.9
2.2	Tube plates	Rolled steel	3.3
		Copper alloys	4.1
2.3	Tubes	Seamless steel	3.4
		Copper alloys	4.1
2.4	Reinforcing elements, long and short stays	Forged steel	3.7
		Rolled steel	3.3
2.5	Bodies of valves for pressure of 0,7 MPa and over, 50 mm in diameter and over	Forged steel	3.7
		Cast steel	3.8
		Copper alloys	4.1
		Cast iron	3.9
Note. The material shall be selected according to 1.4.			

.2 construction drawings for the components listed in Table 1.3.3, unless all necessary data are shown in the drawings mentioned in 1.3.4.1.1;

.3 valve replacement with technical data;

.4 strength calculations made in accordance with the present Part of the Rules for components subject to pressure other than valves, flanges and fastenings if the latter comply with the standards approved by the Register;

.5 calculation of cross-sectional area of safety valves;

.6 welding process;

.7 drawings of oil burning equipment, chambers and arrangements for combustion of oil residues and garbage (for incinerator boilers);

.8 for thermal liquid boilers: circuit scheme of the system with description and indication of working parameters, drawings of expansion, drainage tanks and storage tank;

.9 bench test programme.

1.3.4.2 Documentation on automatic control system, protective devices and alarms, as well as on automatic oil burning installations shall be submitted in accordance with the requirements of 3.2.9, Part I "Classification" and 1.4, Part XV "Automation".

1.4 MATERIALS

1.4.1 Materials intended for manufacture of components of boilers, heat exchangers and pressure vessels shall satisfy the requirements of the relevant chapters of Part XIII "Materials" specified in column 4 of Table 1.3.3.

Materials for components of boilers, heat exchangers and pressure vessels of Class III as well as components specified in items 1.5 and 2.5 of Table 1.3.3 may also be selected in accordance with the standards. In this case, the use of materials is subject to agreement with the Register during consideration of the technical documentation.

Materials for components of boilers, heat exchangers and pressure vessels of Class I and Class II, which are listed in Table 1.3.3 (except components specified in items 1.5 and 2.5), are subject to survey by the Register during manufacture.

1.4.2 Carbon and carbon-manganese steels are permitted for manufacture of components of boilers, heat exchangers and pressure vessels at design temperatures up to 400 °C, and low-alloy steel, at design medium temperatures up to 500 °C. The use of these steels for media with temperatures above the specified values may be permitted on condition that their mechanical properties and average stress to produce rupture in 100000 h satisfy the current

standards and are guaranteed by the manufacturer at the specified elevated temperature. For media with temperatures above 500 °C the components, valves of boilers and heat exchangers shall generally be made of alloy steel.

1.4.3 For heat exchangers and pressure vessels with design medium temperatures below 250 °C, on agreement with the Register, hull structural steel may be used according to the requirements of 3.2, Part XIII "Materials".

For some components of heat exchangers and pressure vessels with working pressures below 0,7 MPa and design medium temperatures below 120 °C semi-killed steel may be used on agreement with the Register.

1.4.4 When the yield stress at the elevated temperature is taken as the design characteristic of the material (refer to 2.1.4.1), tensile tests of the material shall be carried out at the design wall temperature; when the design characteristic is the average stress to produce rupture in 100 000 h, the data on the average stress at the design wall temperature shall be submitted to the Register.

1.4.5 During the use of alloy steel for boilers, heat exchangers and pressure vessels it is necessary to submit to the Register data on mechanical properties, average stress at the design wall temperature for steel and welded joints, technological characteristics, welding technique and heat treatment.

The use of cast iron and copper alloys for valves of thermal fluid boilers is not permitted.

1.4.6 Boiler valves of nominal diameter from 50 up to 200 mm designed for working pressure up to 1 MPa and temperatures up to 350 °C may be manufactured from spheroidal or nodular graphite cast iron of entirely ferritic structure meeting the requirements of Table 3.9.3.1, Part XIII "Materials".

For the same valves with nominal diameter d below 50 mm, the product $p \cdot d$ shall not exceed 250 MPa·mm.

1.4.7 Components and valves of heat exchangers and pressure vessels with diameters up to 1000 mm and working pressures up to 1 MPa may be manufactured from spheroidal or nodular graphite cast iron of entirely ferritic structure meeting the requirements of Table 3.9.3.1, Part XIII "Materials".

1.4.8 The use of copper alloys for components of boilers, heat exchangers and pressure vessels as well as for their valves is allowed at design medium temperatures up to 250 °C and working pressures up to 1,6 MPa.

1.4.9 For components specified under items 1.2 and 2.3 of Table 1.3.3, on agreement with the Register, electric welded tubes with longitudinal seams may be used if it is demonstrated that they are equivalent to seamless tubes (refer also to 3.2.14).

1.4.10 Composite materials (structures made of laminated fibrous composite materials and metals, having cylindrical or spherical configuration) may be used in pressure vessels for the design temperatures not higher than 60 °C. The manufacturer or designer shall submit to the Register full details of the materials used (structure and density of reinforcement, moduli of elasticity and shear, yield point, tensile strength, ultimate strains, impact toughness, low cycle fatigue resistance, etc). Moreover, details of product structure, method of manufacture (residual stresses after liner moulding, heat treatment, etc), working environment and service loads shall be submitted as well.

1.5 WELDING

1.5.1 Welding and non-destructive testing of welded joints shall comply with the requirements specified in Part XIV "Welding".

1.5.2 Typical examples of allowable welded joints are given in the Appendix.

Strength of the structures using fillet joints or joints affected by bending stresses shall be checked by the strength and fatigue calculations.

1.6 HEAT TREATMENT

1.6.1 Components, in which the material structure may undergo changes after welding or plastic working, shall be subjected to appropriate heat treatment.

When performing heat treatment of a welded structure, the requirements of 2.4.4, Part XIV "Welding" shall be duly observed.

1.6.2 Heat treatment is required for:

.1 plate-steel elements of boilers, vessels and heat exchangers, which are subjected during manufacture to cold stamping, bending and flanging resulting in plastic deformation of surface fibres exceeding 5 %;

.2 tube plates welded of several components (heat treatment, in this case, may be performed before drilling for tube holes);

.3 welded end plates manufactured by cold stamping;

.4 elements subjected to hot forming, with the temperature at the end of this process being lower than that of forging;

.5 welded structures manufactured from steels with a carbon content higher than 0,25 per cent.

1.7 TESTS

1.7.1 On completion of manufacture or assembly all the components of boilers, heat exchangers and pressure vessels shall be subjected to hydraulic tests in accordance with the requirements of Table 1.7.1.

1.7.2 Hydraulic tests shall be carried out on completion of all welding operations and prior to application of insulation and protective coatings.

1.7.3 Where an all-round inspection of the surfaces to be tested is difficult or impossible after assembling the individual components and units, they shall be tested prior to assembling.

1.7.4 The dimensions of components to be tested under test pressure $p_w + 0,1$ MPa and also of components to be tested under test pressure above the value given in Table 1.7.1 shall be checked by calculation to this pressure. The stresses involved shall not exceed 0,9 times the yield stress of the material.

1.7.5 After installation on board the ship the steam boilers shall be steam tested under working pressure.

1.7.6 After installation on board the ship the air receivers shall be air tested under working pressure, with all valves complete.

1.7.7 Heat exchangers and vessels incorporated in refrigerating plants shall be tested as specified in 12.1, Part XII "Refrigerating Plants".

1.8 BOILER ROOMS AND SPARE PARTS

1.8.1 The boiler rooms shall satisfy the requirements of 4.2 to 4.5, Part VII "Machinery Installations".

1.8.2 The requirements for spare parts are specified in 10.1 and Table 10.2-7, Part VII "Machinery Installations".

See Circular 1163c

Table 1.7.1

Nos	Boilers, heat exchangers, pressure vessels and components	Test pressure p_h , MPa	
		after manufacture or joining of strength shell elements without valves	after assembly, with valves installed
1	Boilers, steam superheaters, economizers and their components operating at temperatures below 350 °C	$1,5p_w$, but not less than $p_w + 0,1$ MPa	$1,25p_w$, but not less than $p_w + 0,1$ MPa
2	Thermal liquid boilers	$1,5p_w$, but not less than $p_w + 0,1$ MPa	$1,5p_w$, but not less than $p_w + 0,1$ MPa
3	Steam superheaters and their components operating at temperatures of 350 °C and above	$1,5p_w \frac{R_{eL/350}}{R_{eL/t}}$	$1,25p_w$
4	Heat exchangers, pressure vessels and their components operating at temperatures below 350 °C and pressure ^{1,2} : up to 15 MPa above 15 MPa	$1,5p_w$, but not less than $p_w + 0,1$ MPa $1,35p_w$	— —
5	Heat exchangers and their components operating at temperature 350 °C and above and pressure ² : up to 15 MPa above 15 MPa	$1,5p_w \frac{R_{eL/350}}{R_{eL/t}}$ $1,35p_w \frac{R_{eL/350}}{R_{eL/t}}$	— —
6	Oil burning equipment components subject to fuel oil pressure	—	$1,5p_w$, but not less than 1 MPa
7	Gas spaces of waste-heat boilers	—	To be tested by air pressure at 0,01 MPa
8	Boiler valves	As per 1.3 of Part IX "Machinery", but not less than $2p_w$	To be tested for tightness of closure at $1,25p_w$
9	Feed valves of boilers and shut-off valves of thermal liquid boilers	$2,5p_w$	Ditto
10	Valves of heat exchangers and pressure vessels	As per 1.3 of Part IX "Machinery"	Ditto
<p>Symbols:</p> <p>p_h = test pressure, MPa;</p> <p>p_w = working pressure, MPa, but not less than 0,1MPa;</p> <p>$R_{eL/350}$ = lower yield stress of material at 350 °C, MPa;</p> <p>$R_{eL/t}$ = lower yield stress at operating temperature, MPa.</p>			
<p>¹For testing ICE coolers, refer to Table 1.3.3, Part IX "Machinery".</p> <p>²With $p_w = 15 \div 16,6$ MPa, $p_h \geq 22,5$ MPa.</p>			

2 STRENGTH CALCULATIONS

2.1 GENERAL

2.1.1 Application.

2.1.1.1 The wall thicknesses obtained by calculation are the lowest permissible values under normal operating conditions.

The standards and methods of strength calculation do not take into account the manufacture tolerances for thicknesses, which shall be added as special allowances to the design thickness values.

Additional stresses due to external loads (axial forces, bending moments and torques) acting upon the element under calculation (in particular, loads due to its own mass, the mass of attached elements, etc.) shall be specially taken into account as required by the Register.

2.1.1.2 The dimensions of structural elements of boilers, heat exchangers and pressure vessels, for which no strength calculation methods are given in the present Rules, shall be determined on the basis of experimental data and proved theoretical strength calculations under common and agreed with the Register standards.

2.1.2 Design pressure.

2.1.2.1 The design pressure to be used for strength calculations of the elements of boilers, heat exchangers and pressure vessels shall generally be taken equal to the working pressure of the medium.

The hydrostatic pressure shall be taken into account in the design pressure calculations when it exceeds 0,05 MPa.

2.1.2.2 For uniflow and forced-circulation boilers the design pressure shall be determined with due consideration for the hydrodynamic resistances in boiler elements at the design steaming capacity.

2.1.2.3 For flat walls subject to pressure on both sides, the design pressure shall be taken as equal to the maximum pressure acting on the walls.

The walls with curved surfaces subject to pressure on both sides shall be designed both for the internal and external pressures.

Where the pressure on one side of the wall with flat or curved surface is below the atmospheric pressure, the design pressure shall be taken as equal to the maximum pressure acting on the other side of the wall plus 0,1 MPa.

2.1.2.4 For economizers the design pressure shall be taken as equal to the sum total of the working pressure in the boiler steam drum and the hydrodynamic resistances in the economizer, piping and valves at boiler design steaming capacity.

2.1.2.5 For heat exchangers and pressure vessels incorporated in refrigerating plants the design

pressure shall be taken as specified in 2.2.2, Part XII "Refrigerating Plants".

2.1.3 Design temperature.

2.1.3.1 For the purpose of determining the allowable stresses depending on the temperature of the medium and heating conditions, the design wall temperature shall be taken as not lower than that indicated in Table 2.1.3.1.

2.1.3.2 The design wall temperature t of steam superheater elements with maximum temperature of superheated steam $t_H > 400^\circ\text{C}$ shall be determined for several steam superheater cross-sections with regard to possible operational increase in temperature of separate elements and parts within the range of any possible operational steaming capacity.

The maximum temperature obtained from calculation for the most stressed cross-sections of the steam superheater shall be taken as a design temperature.

The rated design temperature of steam superheater tube walls at $t_H > 400^\circ\text{C}$ (refer to 2.5 of Table 2.1.3.1) is obtained from the formula

$$t = t_a + \Delta t_q + \Delta t \quad (2.1.3.2-1)$$

where t_a = mean temperature of steam in the tube cross-section under consideration, $^\circ\text{C}$. t_a is determined from the analysis of thermal conditions of the steam superheater operation and its layouts and also from the results of thermal calculations for the boiler;

Δt_q = mean difference between the design temperature of the tube wall and steam temperature in the tube cross-section under consideration, $^\circ\text{C}$. To determine this difference, it is necessary to calculate or obtain from the boiler thermal calculations the following values:

α_1 = coefficient of heat transfer from flue gases to the tube wall taken as a mean value around the circumference of the tube, $\text{W}/(\text{m}^2\cdot\text{K})$;

α_2 = coefficient of heat transfer from the tube wall to steam, $\text{W}/(\text{m}^2\cdot\text{K})$;

α_3 = coefficient of heat transfer by radiator, $\text{W}/(\text{m}^2\cdot\text{K})$;

t_k = temperature of flue gases in front of the row of tubes under consideration, $^\circ\text{C}$;

Δt_q is determined from Fig. 2.1.3.2-1.

For determination of Δt_q an auxiliary value A_0 is derived from the formula

$$A_0 = k_0 \frac{1,6\alpha_1 + \alpha_3}{\alpha_2} \quad (2.1.3.2-2)$$

where k_0 = coefficient obtained from Fig. 2.1.3.2-2.

For heated tubes of steam superheaters Δt is dependent upon the coefficient k of uneven heat absorption over the width of the superheater gas flue and upon the steam temperature increment Δt_v at the portion measured from the point of steam entry into the tube to the cross-section under consideration, the value t being obtained from Fig. 2.1.3.2-3.

Table 2.1.3.1

Nos	Boiler, heat exchanger, pressure vessel elements and operating conditions thereof	Design wall temperature, °C
1 =	Elements exposed to radiant heat	
1.1	Boiler tubes	$t_M + 50$
1.2	Steam superheater tubes	$t + 50$
1.3	Corrugated furnaces	$t_M + 75$
1.4	Plain furnaces, headers, combustion and other chambers	$t_M + 90$
2 =	Elements heated by hot gases but protected against radiant heat effect ¹	
2.1	Shells, end plates, headers, chambers, tube plates and boiler tubes	$t_M + 30$
2.2	Headers and steam superheater tubes at steam temperatures up to 400 °C	$t_M + 35$
2.3	Headers and steam superheater tubes at steam temperatures above 400 °C	$t_M + x\Delta t + 25$
2.4	Waste-heat boilers operating without flame cleaning of heating surfaces	$t_M + 30$
2.5	Waste-heat boilers operating with flame cleaning of heating surfaces	t_v
3 =	Elements heated by steam or fluids	t_v
4 =	Non-heated elements ²	t_M

Symbols:
 t_M = maximum temperature of heated medium in the element under consideration, °C;
 t_v = maximum temperature of heating fluid, °C;
 t = rated design temperature of the tube wall determined from 2.1.3.2, °C;
 Δt = steam temperature increase in the most heat-stressed tube as against the mean temperature t_a (refer to 2.1.3.2), °C;
 x = factor characterizing steam mixing in the steam superheater header:
 $x = 0$ at the concentrated steam supply to the header sides and ends;
 $x = 0,5$ at the uniform dispersed steam supply to the header.

¹Refer to 2.1.3.4.
²Refer to 2.1.3.3.

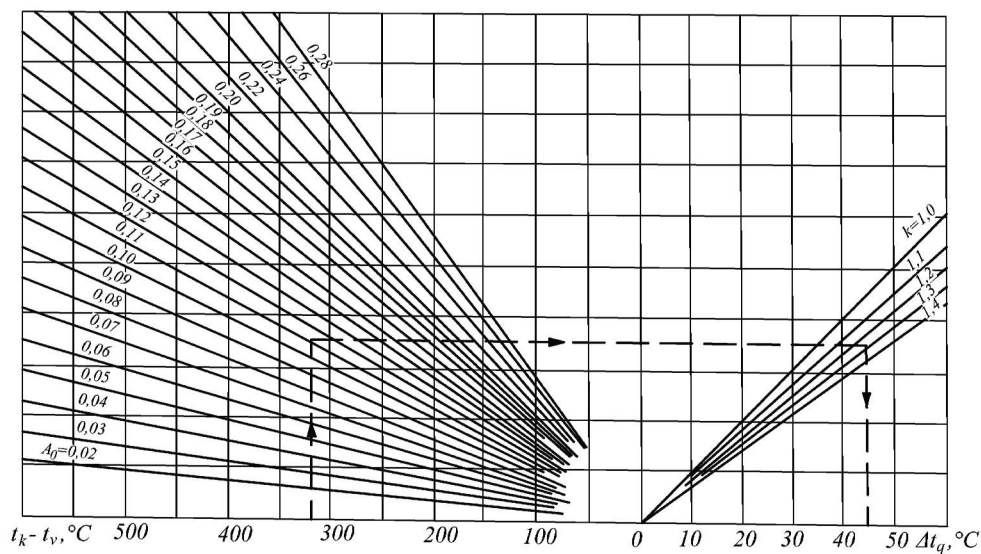

Fig. 2.1.3.2-1

Coefficient k is taken to be equal to:

- 1,3 — for vertical water-tube boilers of conventional type with loop or coil superheater;
- 1,2 — for U-type top-fired boilers with coil superheaters.

Note. In calculation of non-heated headers and tubes of superheaters with $t_H > 400$ °C the value Δt_v represents the full temperature increment in the superheater step or section under consideration.

2.1.3.3 The walls are considered to be non-heated in the following cases:

- .1 the walls are separated from the combustion space or uptake by fire-resistant insulation, the distance between walls and insulation being 300 mm and over; or
- .2 the walls are protected with fire-resistant insulation not exposed to radiant heat.

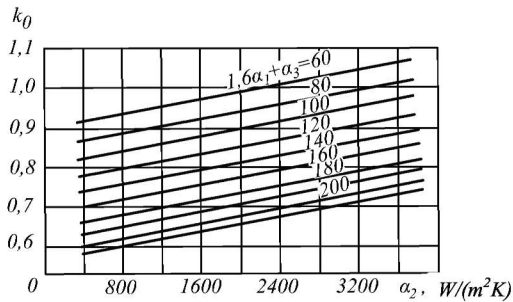

Fig. 2.1.3.2-2

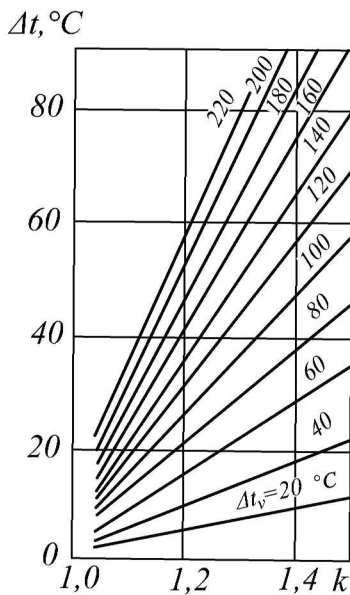

Fig. 2.1.3.2-3

2.1.3.4 The walls are considered to be protected from radiant heat effect in the following cases:

.1 the walls are protected with fire-resistant insulation; or

.2 the walls are protected by a closely spaced row of tubes (with a maximum clearance between the tubes in the row up to 3 mm); or

.3 the walls are protected by two staggered rows of tubes with a longitudinal pitch equal to a maximum of two outside tube diameters or by three or more staggered rows of tubes with a longitudinal pitch equal to a maximum of two and a half outside tube diameters.

2.1.3.5 The design temperature for heated walls of the boiler and non-heated walls of the steam-conducting boiler elements shall not be less than 250 °C.

2.1.3.6 Non-insulated boiler walls measuring over 20 mm in thickness and heated by flue gases may be used only at gas temperatures up to 800 °C. If, with wall thicknesses measuring less than 20 mm and flue

gas temperatures running higher than 800 °C, there are areas extending over 8 tube diameters and unprotected by insulation or by tube rows, the design wall temperature shall be determined by thermal stress analysis.

The requirements concerning the wall protection from radiant heat effect are given in 3.2.8.

2.1.3.7 The design wall temperature for heat exchangers and pressure vessels operating under coolant pressure shall be taken as equal to 20 °C if occurrence of higher temperature is not possible.

2.1.4 Strength characteristics of materials and allowable stresses.

2.1.4.1 When determining the allowable stresses in carbon and alloy steels with the ratio of the upper yield stress R_{eH} to tensile strength R_m not exceeding 0,6, the lower yield stress $R_{eL/t}$ or proof stress $R_{p0,2/t}$ and the average stress to produce rupture in 100 000 h $R_{m/t100000}$ at design temperatures shall be adopted as design characteristics.

For steels having the ratio of the upper yield stress to tensile strength above 0,6, the tensile strength $R_{m/t}$ at design temperature shall be adopted additionally.

For steels, the service conditions of which are characterized by creep (at temperatures above 450 °C), irrespective of the value of the ratio R_{eH}/R_m , the creep strength $R_{1\%(10^5)/t}$ at design temperature shall be added to the above characteristics.

Minimum values of $R_{eL/t}$, $R_{p0,2/t}$ and $R_{m/t}$ as stipulated by the steel specifications shall be adopted, while of $R_{m/t}$ and $R_{1\%(10^5)/t}$ average values shall be adopted.

2.1.4.2 For materials having no clearly defined yield stress point, the minimum tensile strength value $R_{m/t}$ at the design temperature shall be taken as the design characteristic.

2.1.4.3 For spheroidal or nodal graphite cast iron and ductile cast iron with ferritic-perlitic and perlitic structure and with elongation less than 5 per cent, the minimum tensile strength value R_v at 20 °C shall be taken as the design strength characteristic.

For cast irons with ferritic structure and elongation more than 5 per cent, the lesser of two values given below shall be taken as the design strength characteristic:

R_v = minimum ultimate strength of material at 20 °C; or

$R_{0,2}$ = proof stress at 20 °C, at which the permanent elongation is 0,2 per cent.

2.1.4.4 When non-ferrous metals and their alloys are used, it shall be taken into account that the heating during working or welding tends to relieve them of the strengthening effects realized under cold conditions. Therefore, the strength characteristics to be used for strength calculations of components and

assemblies manufactured from such materials shall be those applied to their heat-treated condition.

2.1.4.5 The recommended values of the design characteristics of steel at higher temperatures are given in Tables 7.1 and 7.2.

For the materials omitted from these tables, strength characteristics are taken according to the standards agreed with the Register.

2.1.4.6 The allowable stress σ , in MPa, used for determining the scantlings shall be adopted equal to the smallest of the following values (bearing the requirements of 2.1.4.1 to 2.1.4.5 in mind):

$$\begin{aligned}\sigma &= \frac{R_{m/t}}{n_t}; \\ \sigma &= \frac{R_{1\%(10^5)/t}}{n_{cr}}; \\ \sigma &= \frac{R_{eL/t}}{n_y} \quad (\text{or } \sigma = \frac{R_{p0,2/t}}{n_y}); \\ \sigma &= \frac{R_{m/t_{100000}}}{n_{av}}\end{aligned}\quad (2.1.4.6)$$

where n_t = tensile strength safety factor;
 n_{cr} = creep strength safety factor;
 n_y = yield stress safety factor;
 n_{av} = safety factor for the average stress to produce rupture in 100000 h.

The factors are chosen in accordance with 2.1.5.

2.1.5 Safety factors.

2.1.5.1 For items manufactured of steel forgings and rolled steel, which are under internal pressure, the safety factors shall be chosen of at least:

$$n_y = n_{av} = 1,6; \quad n_t = 2,7; \quad n_{cr} = 1,0.$$

For items under external pressure, the safety factors n_y , n_{av} and n_t shall be increased by 20 per cent.

2.1.5.2 For components of boilers, heat exchangers and pressure vessels of Class II and Class III, which are made of steels having the ratio $R_{eH}/R_m \leq 0,6$, the safety factors may be adopted as follows:

$$n_y = n_{av} = 1,5; \quad n_t = 2,6.$$

2.1.5.3 For components of boilers, heat exchangers and pressure vessels, which are made of cast steel and are under internal pressure in service, the safety factors shall be chosen of at least:

$$n_y = n_{av} = 2,2; \quad n_t = 3,0; \quad n_{cr} = 1,0.$$

For items that are under external pressure in service, the safety factors shall be increased by 20 % (except for n_{cr} , which shall remain equal to 1).

2.1.5.4 For essential boiler components being under thermal stress, the safety factors n_y and n_{av} shall be adopted equal to:

3,0 for corrugated furnaces;

2,5 for plain furnaces, combustion chambers, stay tubes, long and short stays;

2,2 for gas uptake pipes subjected to pressure or other similar gas heated walls.

2.1.5.5 When determining scantlings for the items made of grey cast iron, spheroidal or nodular graphite cast iron and ductile cast iron with ferritic-perlitic and perlitic structure having elongation less than 5 per cent, the tensile strength safety factor n_t shall be adopted equal to 4,8 after annealing and to 7,0 without annealing both for the case of internal and external pressure.

For the items made of cast iron with ferritic structure having elongation more than 5 per cent, the tensile strength safety factor n_t shall be adopted equal to 4,0 for the case of internal pressure and 4,8 for the case of external pressure and the proof strength safety factor n_p shall be taken equal to 2,8.

2.1.6 Efficiency factors.

2.1.6.1 Efficiency factor of welded joints shall be selected from Table 2.1.6.1-1 depending on the type of joint and welding method used; efficiency factor of welded joints depending on the class of boilers, heat exchangers and pressure vessels (refer to 1.3.1.2) shall not be below the values given in Table 2.1.6.1-2.

2.1.6.2 The ligament efficiency factor of cylindrical walls weakened by holes of the same diameter shall be taken as equal to the lowest of the following three values:

1 the ligament efficiency factor of cylindrical walls weakened by a longitudinal row or a field of unstaggered, equally-pitched holes (refer to Fig. 2.1.6.2.1), as determined by the following formula:

$$\varphi = (a - d)/a; \quad (2.1.6.2.1)$$

2 the ligament efficiency factor, reduced to the longitudinal direction, of cylindrical walls weakened by a transverse row or a field of equally-pitched holes (refer to Fig. 2.1.6.2.1), as determined by the following formula:

$$\varphi = 2(a_1 - d)/a_1; \quad (2.1.6.2.2)$$

3 the ligament efficiency factor, reduced to the longitudinal direction, of cylindrical walls weakened by a field of staggered and equally-spaced holes (refer to Fig. 2.1.6.2.3), as determined by the following formula:

$$\varphi = k(a_2 - d)/a_2 \quad (2.1.6.2.3)$$

where d = diameter of the hole for expanded tubes or inside diameter of welded-on tubes and upset nozzles, mm;
 a = pitch between two adjacent hole centres in the longitudinal direction, mm;
 a_1 = pitch between two adjacent hole centres in the transverse (circumferential) direction (taken as a mean circumference arc), mm;
 a_2 = pitch between two adjacent hole centres in the diagonal direction, in mm, as determined by the following formula:

$$a_2 = \sqrt{p^2 + k_1^2};$$

Table 2.1.6.1-1

Welding	Welded joint	Weld seam	ϕ
Automatic welding	Butt joint	Double-sided	1,0
		Single-sided on backing strip	0,9
	Overlap joint	Single-sided without backing strip	0,8
		Double-sided	0,8
Machine welding and manual welding	Butt joint	Single-sided	0,7
		Double-sided	0,9
		Single-sided on backing strip	0,8
	Overlap joint	Single-sided without backing strip	0,7
		Double-sided	0,7
	Single-sided	0,6	

Notes: 1. In any case, full root penetration shall be provided.
2. For electroslag welding the efficiency factor of welded joints is taken as $\phi = 1,0$.

Table 2.1.6.1-2

Item	Efficiency factor of welded joints ϕ depending on class of boilers		
	Class I	Class II	Class III
Boilers, steam superheaters and steam accumulators	0,90	0,80	—
Steam-heated steam generators	0,90	0,80	—
Heat exchangers and pressure vessels	0,90	0,70	0,60

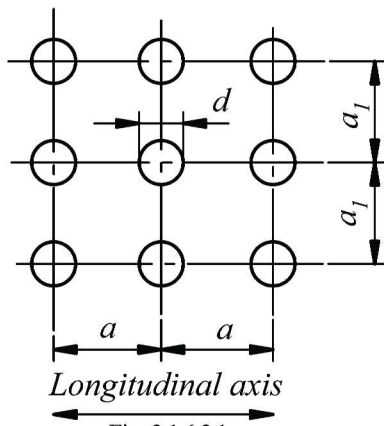

Fig. 2.1.6.2.1

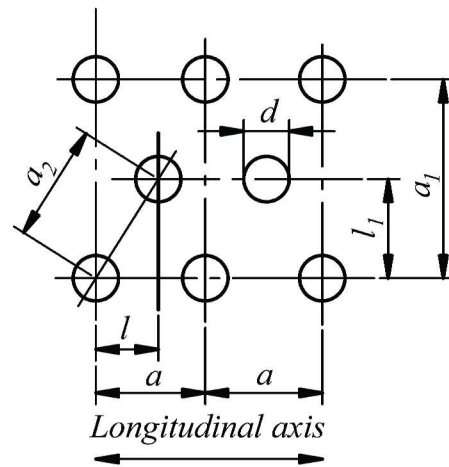

Fig. 2.1.6.2.3

Table 2.1.6.2.3

l_1/l	k	l_1/l	k	l_1/l	k	l_1/l	k
5,0	1,76	3,5	1,65	2,0	1,41	0,5	1,00
4,5	1,73	3,0	1,60	1,5	1,27	—	—
4,0	1,70	2,5	1,51	1,0	1,13	—	—

Note. Intermediate values of k are determined by interpolation.

l = centre-to-centre distance between two adjacent holes in the longitudinal direction (refer to Fig. 2.1.6.2.3), mm;
 l_1 = centre-to-centre distance between two adjacent holes in the transverse (circumferential) direction (refer to Fig. 2.1.6.2.3), mm;
 k = factor selected from Table 2.1.6.2.3 in dependence upon the ratio of l_1/l .

2.1.6.3 Where rows or fields of equally-pitched holes contain holes of alternate diameters, in Formulae (2.1.6.2.1), (2.1.6.2.2) and (2.1.6.2.3) for ligament efficiency factor determination value d shall be replaced by a value equal to the arithmetic mean of two largest adjacent hole diameters.

In the case of unequal pitch between holes of equal diameter, the formulae for ligament efficiency factor determination shall be used with the lowest values of a , a_1 and a_2 .

2.1.6.4 Where a welded joint has a hole or where the distance between the edge of a hole nearest to the welded joint centre is less than 50 mm or less than one-half the width of the mostly local opening affected zone, Q , in mm, determined by Formula (2.1.6.4), the efficiency factor shall be taken as equal to the product of the efficiency factor of welded joint by the ligament efficiency factor of the wall weakened by holes. In cases where the hole edge is at a distance more than 0,5 Q and more than 50 mm from the welded joint centre the lowest of the values determined for the ligament efficiency factors of the

wall weakened by holes and the efficiency factor of welded joint shall be taken as the efficiency factor. The width of the mostly local opening affected zone, Q , in mm, is calculated by the formula

$$Q = \sqrt{D_m(s-c)} \quad (2.1.6.4)$$

where s = wall thickness, in mm;
 c = corrosion allowance, in mm, taken according to 2.1.7;
 D_m = mean diameter of the weakened wall, in mm;
 For cylindrical walls and dished ends
 $D_m = D + s$ or $D_m = D_a - s$.
 For conical walls
 $D_m = (D_a/\cos\alpha) - s$ or $D_m = (D/\cos\alpha) - s$
 where D_a = outside diameter;
 D = inside diameter.
 For conical walls D and D_a are measured across a section, which passes through the centre of the weakening hole;
 α = angle between conical wall and central axis (refer to Fig. 2.3.1-1).

2.1.6.5 For seamless cylindrical walls not weakened by welds or rows/fields of holes, the ligament efficiency factor shall be taken equal to 1. In no case shall the factor be taken higher than 1.

2.1.6.6 The ligament efficiency factor of walls weakened by holes for expanded tubes shall be taken as not less than 0,3 as determined by Formulae (2.1.6.2.1), (2.1.6.2.2) and (2.1.6.2.3).

2.1.6.7 Where cylindrical walls are manufactured from plates of various thickness, jointed together by longitudinal welds, wall thickness calculation shall be made for each plate separately, taking into account the weakenings.

2.1.6.8 For longitudinally welded tubes the efficiency factor of welded joints shall be chosen in accordance with 2.1.6.1.

2.1.6.9 The ligament efficiency factors for cylindrical and conical walls and dished ends weakened by isolated openings shall be determined by the formulae:

for single non-reinforced openings:

$$\varphi_{in} = \frac{2}{d/Q + 1,75} \quad (2.1.6.9-1)$$

for single reinforced openings:

$$\varphi_{ir} = \varphi_{in} \left(1 + \frac{\Sigma f}{2(s-c)Q} \right) \quad (2.1.6.9-2)$$

where Σf = the sum of compensating reinforcement areas, in mm², determined according to 2.9;
 d = opening diameter, in mm;
 s = wall thickness, in mm;
 c = corrosion allowance, in mm, taken according to 2.1.7;
 Q = determined according to 2.1.6.4.

2.1.6.10 When determining the permissible thicknesses of cylindrical, spherical, conical elements and dished ends, the lowest of the values determined for a row or a field of non-reinforced openings in accordance with 2.1.6.2 to 2.1.6.7 and for single

reinforced and non-reinforced openings determined according to 2.1.6.9 shall be taken as the design efficiency factor.

2.1.6.11 The ligament efficiency factor of flat tube plates shall be determined for tangential and radial pitches by Formula (2.1.6.2.1). The lower of the values thus obtained shall be used for calculating the tube plate thickness.

2.1.7 Design thickness allowances.

2.1.7.1 In all cases where the design wall thickness allowance c is not expressly specified, it shall be taken as equal to at least 1 mm. For steel walls over 30 mm in thickness, walls manufactured from corrosion-resistant or having protective coating non-ferrous or high alloy materials, design wall thickness allowance may be reduced to zero on agreement with the Register.

2.1.7.2 For heat exchangers and pressure vessels, which are inaccessible for internal inspection, or the walls of which are heavily affected by corrosion or wear, the allowance c may be increased if required by the Register.

2.2 CYLINDRICAL AND SPHERICAL ELEMENTS AND TUBES

2.2.1 Elements subject to internal pressure.

2.2.1.1 The requirements given below cover the following conditions:

at $D_a/D \leq 1,6$ for cylindrical walls;

at $D_a/D \leq 1,7$ for tubes;

at $D_a/D \leq 1,2$ for spherical walls.

Cylindrical walls with $D_a \leq 200$ mm are regarded as tubes.

2.2.1.2 The thickness s , in mm, of cylindrical walls and tubes shall not be less than:

$$s = \frac{D_a p}{2\sigma\varphi + p} + c \quad (2.2.1.2-1)$$

or

$$s = \frac{D p}{2\sigma\varphi - p} + c \quad (2.2.1.2-2)$$

where p = design pressure (refer to 2.1.2), MPa;
 D_a = outside diameter, mm;
 D = inside diameter, mm;
 φ = efficiency factor (refer to 2.1.6);
 σ = allowable stress (refer to 2.1.4.6), MPa;
 c = allowance (refer to 2.1.7), mm.

2.2.1.3 Spherical wall thickness shall not be less than:

$$s = \frac{D_a p}{4\sigma\varphi + p} + c \quad (2.2.1.3-1)$$

or

$$s = \frac{Dp}{4\sigma\varphi - p} + c \quad (2.2.1.3-2)$$

The symbols used are the same as in 2.2.1.2.

2.2.1.4 Irrespective of the values obtained from Formulae (2.2.1.2-1), (2.2.1.2-2), (2.2.1.3-1) and (2.2.1.3-2), the thicknesses of spherical and cylindrical walls and tubes shall not be less than:

- .1 5 mm for seamless and welded elements;
- .2 12 mm for tube plates with radial hole arrangement for expanded tubes;
- .3 6 mm for tube plates with welded-on or soldered tubes;
- .4 values given in Table 2.2.1.4, for tubes.

Table 2.2.1.4

D_a , mm	s , mm	D_a , mm	s , mm
< 20	1,75	> 95 ≤ 102	3,25
> 20 ≤ 30	2,0	> 102 ≤ 121	3,5
> 30 ≤ 38	2,2	> 121 ≤ 152	4,0
> 38 ≤ 51	2,4	> 152 ≤ 191	5,0
> 51 ≤ 70	2,6	> 191	5,4
> 70 ≤ 95	3,0		

Note. Reduction in wall thickness due to bending or expansion shall be compensated by allowances.

The thickness of tube walls heated by gases with temperatures exceeding 800 °C shall not be more than 6 mm.

2.2.1.5 On agreement with the Register, the minimum thicknesses of the walls of tubes of non-ferrous alloys and stainless steels may be taken less than those specified in 2.2.1.4, but not less than determined by Formulae (2.2.1.2-1), (2.2.1.2-2), (2.2.1.3-1) and (2.2.1.3-2).

2.2.2 Elements subject to external pressure.

2.2.2.1 The requirements specified below refer to cylindrical walls at $D_a/D \leq 1,2$. The thickness of tubes with $D_a \leq 200$ mm shall be determined from 2.2.1.2.

2.2.2.2 Plain cylindrical walls with or without stiffening members, including plain furnaces of boilers, shall have a thickness s , in mm, not less than

$$s = \frac{50(B + \sqrt{B^2 + 0,04AC})}{A} + c \quad (2.2.2.2-1)$$

$$\text{where } A = 200 \frac{\sigma}{D_m} \left(1 + \frac{D_m}{10l}\right) \left(1 + \frac{5D_m}{l}\right); \quad (2.2.2.2-2)$$

$$B = p \left(1 + 5 \frac{D_m}{l}\right); \quad (2.2.2.2-3)$$

$$C = 0,045pD_m; \quad (2.2.2.2-4)$$

p = design pressure (refer to 2.1.2), MPa;
 D_m = mean diameter, mm;
 σ = allowable stress (refer to 2.1.4.6 and 2.1.5.3), MPa;
 c = allowance (refer to 2.1.7), mm;

l = design length of cylindrical portion between stiffening members, mm.

Assumed as stiffening members may be end plates, furnace connections to end plates and combustion chamber as well as reinforcing rings shown in Fig. 2.2.2.2, or similar structures.

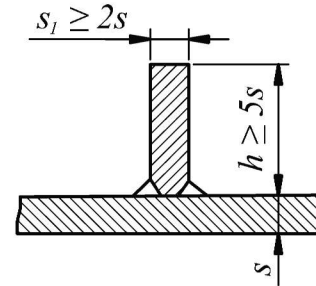

Fig. 2.2.2.2

2.2.2.3 Corrugated furnaces shall have a wall thickness s , in mm, not less than

$$s = \frac{pD}{2\sigma} + c \quad (2.2.2.3)$$

where p = design pressure (refer to 2.1.2), MPa;
 D = minimum inside diameter of the furnace over the corrugated portion, mm;
 σ = allowable stress (refer to 2.1.4.6 and 2.1.5.3), MPa;
 c = allowance (refer to 2.1.7), mm.

2.2.2.4 Where the length of the straight portion of a corrugated furnace from the front end wall to the commencement of the first corrugation exceeds the corrugation length, the wall thickness over this portion shall be obtained from Formula (2.2.2.2-1).

2.2.2.5 The thickness of plain furnaces shall not be less than 7 mm nor more than 20 mm. The thickness of corrugated furnaces shall not be less than 10 mm nor more than 20 mm.

2.2.2.6 Plain furnaces up to 1400 mm in length need not generally be fitted with reinforcing rings.

Where a boiler has two or more furnaces, the reinforcing rings of adjacent furnaces shall be arranged in alternate planes.

2.2.2.7 Holes and openings in cylindrical and spherical walls shall be compensated for as per 2.9.

2.2.2.8 The thickness s_1 , in mm, of the ogee rings (refer to Fig. 2.2.2.8) connecting furnace bottoms of the vertical boilers to the shell and bearing vertical loads shall not be less than that determined by the following formula:

$$s_1 \geq \frac{3,7}{\sigma} \sqrt{pD_1(D_1 - D_0)} + 1 \quad (2.2.2.8)$$

where σ = allowable stress (refer to 2.1.4.6), MPa;
 p = design pressure (refer to 2.1.2), MPa;
 D_1 = inside diameter of the boiler wall, mm;
 D_0 = outside diameter of combustion chamber where it joins the ogee ring.

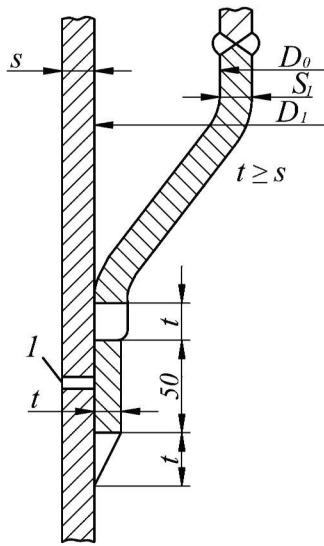

Fig. 2.2.2.8:

l — at least 4 openings 10 mm in diameter equispaced over the shell

2.3 CONICAL ELEMENTS

2.3.1 The wall thickness *s*, in mm, of conical elements subject to internal pressure shall not be less than:

.1 at $\alpha \leq 70^\circ$,

$$s = \frac{D_a p y}{4 \sigma \phi} + c \tag{2.3.1.1-1}$$

and

$$s = \frac{D_c p}{2 \sigma \phi} \frac{1}{\cos \alpha} + c; \tag{2.3.1.1-2}$$

.2 at $\alpha > 70^\circ$,

$$s = 0,3 [D_a - (r + s)] \sqrt{\frac{p}{\sigma \phi}} \frac{\alpha}{90^\circ} + c \tag{2.3.1.2}$$

where *D_c* = design diameter (Figs. 2.3.1-1 to 2.3.1-4), mm;
D_a = outside diameter (Figs. 2.3.1-1 to 2.3.1-4), mm;
p = design pressure (refer to 2.1.2), MPa;
y = shape factor (refer to Table 2.3.1);
 $\alpha, \alpha_1, \alpha_2, \alpha_3$ = angles (refer to Figs. 2.3.1-1 to 2.3.1-4), deg.;
 σ = allowable stress (refer to 2.1.4.6), MPa;
 ϕ = efficiency factor (refer to 2.1.6); in Formulae (2.3.1.1-1) and (2.3.1.2) the efficiency factor of a circumferential welded joint shall be used, and in Formula (2.3.1.1-2) that of a longitudinal welded joint; for seamless shells, as well as in situations where circumferential weld is removed from the edge to a distance exceeding $0,5 \sqrt{D_a s} / \cos \alpha$ the efficiency factor of the welded joint shall be taken equal to 1;
c = allowance (refer to 2.1.7), mm;
r = radius of edge curvature (refer to Figs. 2.3.1-1, 2.3.1-2 and 2.3.1-4), mm.

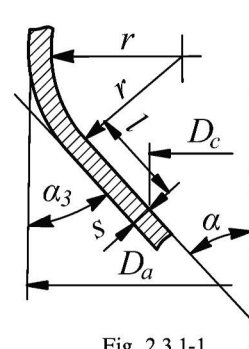

Fig. 2.3.1-1

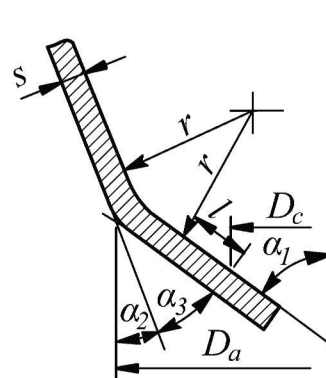

Fig. 2.3.1-2

Table 2.3.1

α , deg.	Shape factor <i>y</i> at r/D_a equal to:											
	0,01	0,02	0,03	0,04	0,06	0,08	0,10	0,15	0,20	0,30	0,40	0,50
10	1,4	1,3	1,2	1,1	1,1	1,1	1,1	1,1	1,1	1,1	1,1	1,1
20	2,0	1,8	1,7	1,6	1,4	1,3	1,2	1,1	1,1	1,1	1,1	1,1
30	2,7	2,4	2,2	2,0	1,8	1,7	1,6	1,4	1,3	1,1	1,1	1,1
45	4,1	3,7	3,3	3,0	2,6	2,4	2,2	1,9	1,8	1,4	1,1	1,1
60	6,4	5,7	5,1	4,7	4,0	3,5	3,2	2,8	2,5	2,0	1,4	1,1
75	13,6	11,7	10,7	9,5	7,7	7,0	6,3	5,4	4,8	3,1	2,0	1,1

Note. For fillet joints, the shape factor *y* is determined at $r/D_a = 0,01$.

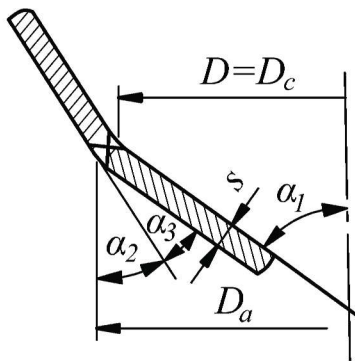

Fig. 2.3.1-3

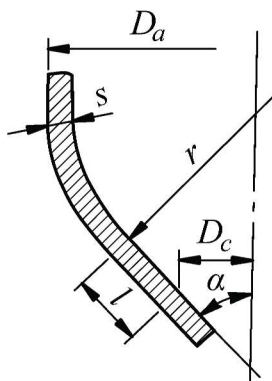

Fig. 2.3.1-4

In Figs. 2.3.1-1, 2.3.1-2 and 2.3.1-4, l is the distance, in mm, from the edge of the wide end of the conical shell, parallel to the generatrix of the conical shell assumed equal to 10 thicknesses, but not larger than half the length of the conical shell generatrix.

2.3.2 The wall thickness s , in mm, of conical elements subject to external pressure shall be determined from 2.3.1 having regard to the following conditions:

.1 efficiency factor of welded joints ϕ shall be taken equal to 1;

.2 allowance c shall be taken equal to 2 mm;

.3 design diameter D_c is determined by the following formula:

$$D_c = \frac{d_1 + d_2}{2} \frac{1}{\cos \alpha} \quad (2.3.2.3)$$

where d_1 and d_2 = cone maximum and minimum diameters, mm;

.4 at $\alpha < 45^\circ$ it shall be demonstrated that no elastic concave deformation of the walls occurs. The pressure p_1 , in MPa, at which the elastic concave deformation of the walls occurs, shall be determined by the following formula:

$$p_1 = 26E \cdot 10^{-6} \frac{D_c}{l_1} \left[\frac{100(s-c)}{D_c} \right]^2 \sqrt{\frac{100(s-c)}{D_c}} \quad (2.3.2.4)$$

where E = modulus of elasticity, MPa;

l_1 = cone maximum length or distance between reinforcements, mm.

The condition for absence of elastic concave deformation is $p_1 > p$ where p = design pressure, MPa.

2.3.3 Fillet welded joints (refer to Fig. 2.3.1-3) are allowed only at $\alpha_3 \leq 30^\circ$ and $s \leq 20$ mm. The joint shall be welded on both sides. For conical shells with $\alpha \geq 70^\circ$, fillet joints may be welded without edge preparation if the requirements of 2.3.2 are met.

It is recommended that fillet joints shall not be used on boilers.

2.3.4 Holes and openings in conical walls shall be reinforced according to 2.9.

2.4 FLAT WALLS, END PLATES AND COVERS

2.4.1 Flat end plates and covers.

2.4.1.1 The thickness s , in mm, of flat end plates unsupported by stays, as well as that of covers (Figs. 2.4.1.1-1 to 2.4.1.1-8 and 1.2 of the Appendix) shall not be less than

$$s = k D_c \sqrt{\frac{p}{\sigma}} + c \quad (2.4.1.1-1)$$

where k = design factor according to Figs. 2.4.1.1-1 to 2.4.1.1-8 and 1.1 to 1.6 of the Appendix;

D_c = design diameter (refer to Figs. 2.4.1.1-2 to 2.4.1.1-7 and 1.6 of the Appendix), mm, determined as follows:
for end plates shown in Figs. 2.4.1.1-1 and 1.1 of the Appendix the design diameter shall be

$$D_c = D - r; \quad (2.4.1.1-2)$$

for rectangular or oval covers (refer to Fig. 2.4.1.1-8) the design diameter shall be

$$D_c = m \sqrt{\frac{2}{1 + (m/n)^2}}; \quad (2.4.1.1-3)$$

D = inside diameter, mm;

r = inside conjugation radius of the end plate, mm;

n and m = major and minor sides or axis of the openings, measured to the centre of the gasket (refer to Fig. 2.4.1.1-8), mm;

p = design pressure (refer to 2.1.2), MPa;

σ = allowable stress (refer to 2.1.4.6), MPa;

c = allowance (refer to 2.1.7), mm.

D_b = circle diameter of fastening bolts (refer to Fig. 2.4.1.1-6), mm;

In Figs. 2.4.1.1-1 and 1.1 of the Appendix, l is the length, mm, of cylindrical portion of end plate.

2.4.1.2 The thickness s , in mm, of the end plates shown in Fig. 1.2 of the Appendix shall not be less than that determined by Formula (2.4.1.1-1).

Additionally, the following conditions shall be satisfied:

.1 for circular end plates

$$0,77s_1 \geq s_2 \geq \frac{1,3p}{\sigma} \left(\frac{D_c}{2} - r \right); \quad (2.4.1.2.1)$$

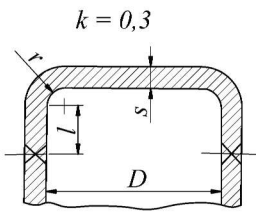

Fig. 2.4.1.1-1

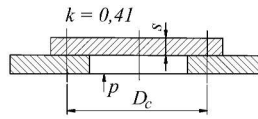

Fig. 2.4.1.1-2

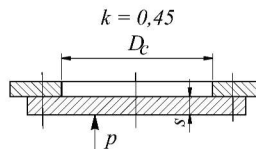

Fig. 2.4.1.1-3

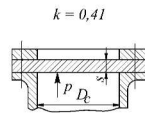

Fig. 2.4.1.1-4

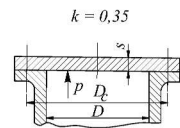

Fig. 2.4.1.1-5

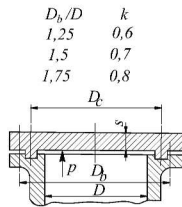

Fig. 2.4.1.1-6

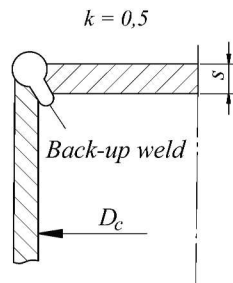

Fig. 2.4.1.1-7

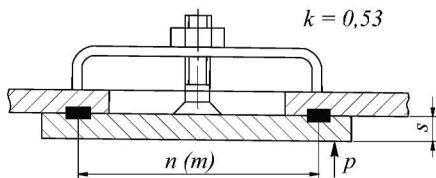

Fig. 2.4.1.1-8

.2 for rectangular end plates

$$0,55s_1 \geq s_2 \geq \frac{1,3p}{\sigma} \frac{mn}{m+n} \quad (2.4.1.2.2)$$

where s_1 = thickness of the shell, mm;
 s_2 = thickness of the end plate in the relieving groove area, mm.

Other symbols used are the same as in 2.4.1.1. In no case shall the value s_2 be less than 5 mm.

The above conditions are applicable to end plates not more than 200 mm in diameter or side length.

2.4.2 Walls reinforced by stays.

2.4.2.1 Flat walls (Figs. 2.4.2.1-2 and 2.4.2.1-3) reinforced by long and short stays, corner stays, stay tubes or other similar structures shall have a thickness s , in mm, not less than

$$s = kD_c \sqrt{\frac{p}{\sigma}} + c \quad (2.4.2.1-1)$$

where k = design factor (refer to Figs. 2.4.2.1-1, 2.4.2.1-2 and 2.4.2.1-3 and also Figs. 5.1, 5.2 and 5.3 of the Appendix).

If the wall area in question is reinforced by stays having different factor k values, Formula (2.4.2.1-1) is used with the arithmetic mean of these factor values;

D_c = design assumed diameter (Figs. 2.4.2.1-2 and 2.4.2.1-3), mm, determined as follows in case of uniform distribution of stays

$$D_c = \sqrt{a_1^2 + a_2^2} \quad (2.4.2.1-2)$$

in case of non-uniform distribution of stays

$$D_c = (a_3 + a_4)/2. \quad (2.4.2.1-3)$$

in all other cases, the value D_c shall be taken equal to the diameter of the largest circle, which can be drawn through the centres of three stays or through the centres of stays and the commencement of the curvature of flanging if the radius of the latter is as specified in 2.4.3. The flanging, in this case, is regarded as a point of support. A manhole flanging shall not be regarded as a point of support;

a_1, a_2, a_3, a_4 = pitch or stay-to-stay distance (Fig. 2.4.2.1-1), mm.

Other symbols used are the same as in 2.4.1.1.

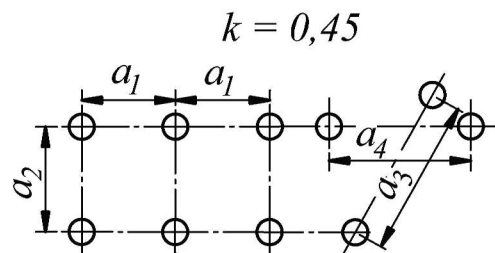

Fig. 2.4.2.1-1

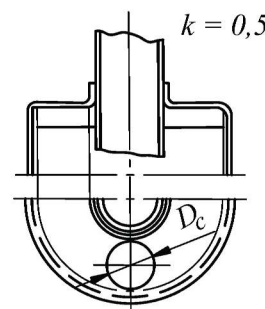

Fig. 2.4.2.1-2

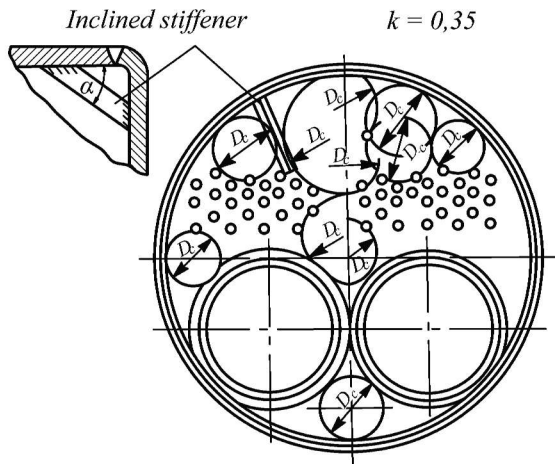

Fig. 2.4.2.1-3

2.4.3 Flanging of flat walls.

2.4.3.1 In flat wall and end plate calculations, the flanging is only taken into account when the flanging radii are not less than those given in Table 2.4.3.1.

Table 2.4.3.1

Radius of flanging, mm	Outside diameter of end plate, mm
25	≤ 350
30	351 to 500
35	501 to 950
40	951 to 1400
45	1401 to 1900
50	> 1900

The minimum flanging radius shall not be less than 1,3 times the wall thickness.

2.4.3.2 The cylindrical portion of a flanged flat end plate shall have a length l not less than $0,5\sqrt{Ds}$ (refer to Fig. 2.4.1.1-1).

2.4.3.3 End plates with a relieving groove shall have a groove curvature radius r according to 1.2 of the Appendix.

2.4.4 Reinforcement of openings.

2.4.4.1 Openings in flat walls, end plates and covers measuring over four thicknesses in diameter shall be reinforced by means of welded-on nozzles, branch pieces and pads, or by increasing the design wall thickness. Openings shall be arranged at a distance of not less than $1/8$ of the size of the opening from the design diameter outline.

2.4.4.2 If the actual wall thickness is larger than that required by Formulae (2.4.1.1-1) and (2.4.2.1-1), the maximum diameter d , in mm, of a non-reinforced opening shall be determined by the following formula:

$$d = 8s_f(1,5 \frac{s_f^2}{s^2} - 1) \quad (2.4.4.2)$$

where s_f = actual wall thickness, mm;
 s = design wall thickness obtained from Formulae (2.4.1.1-1) and (2.4.2.1-1), mm.

2.4.4.3 Edge reinforcement shall be provided for openings of larger dimensions than those indicated in 2.4.4.1 and 2.4.4.2.

The dimensions of reinforcing elements (nozzles and branches), in mm, shall satisfy the expression

$$s_r(h^2/s_f^2 - 0,65) \geq 0,65d - 1,4s_f \quad (2.4.4.3)$$

where s_r = width of reinforcing element (Fig. 2.4.4.3), mm;
 h = height of reinforcing element (Fig. 2.4.4.3), mm.

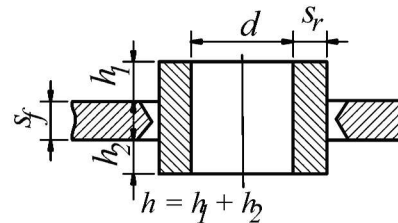

Fig. 2.4.4.3

Other symbols used are the same as in 2.4.4.2.

2.4.4.4 The design heights h_1 and h_2 , in mm, of reinforcing elements (nozzles and branches) (refer to Fig. 2.4.4.3) shall be determined by the following formula:

$$h_1(h_2) \leq \sqrt{(d+s_r)s_r} \quad (2.4.4.4)$$

The symbols used are the same as in 2.4.4.2 and 2.4.4.3.

2.5 TUBE PLATES

2.5.1 The thickness s_1 , in mm, of flat tube plates of heat exchangers shall not be less than

$$s_1 = 0,9kD_B \sqrt{\frac{p}{\sigma\phi}} + c \quad (2.5.1)$$

where p = design pressure (refer to 2.1.2), MPa;
 σ = allowable stress (refer to 2.1.4.6), MPa.

For heat exchangers of rigid construction the allowable stress may be reduced by 10 per cent when the materials of the shell and tubes have different linear expansion coefficients;

c = allowance (refer to 2.1.7), mm;

k = factor depending on the ratio of the shell thickness s to the tube plate thickness s_1 (s/s_1).

For tube plates welded to the shell along the perimeter the factor k is determined from Fig. 2.5.1. The preset value of the thickness s_1 shall be used. When the difference between the preset value of the thickness s_1 and that obtained from Formula (2.5.1) is more than 5 per cent, the recalculation shall be made.

For tube plates fastened between the flanges of the shell and cover by bolts and studs, k is equal to 0,5;

D_B = inside diameter of the shell, mm;

ϕ = ligament efficiency factor of the tube plate weakened by holes (refer to 2.5.2).

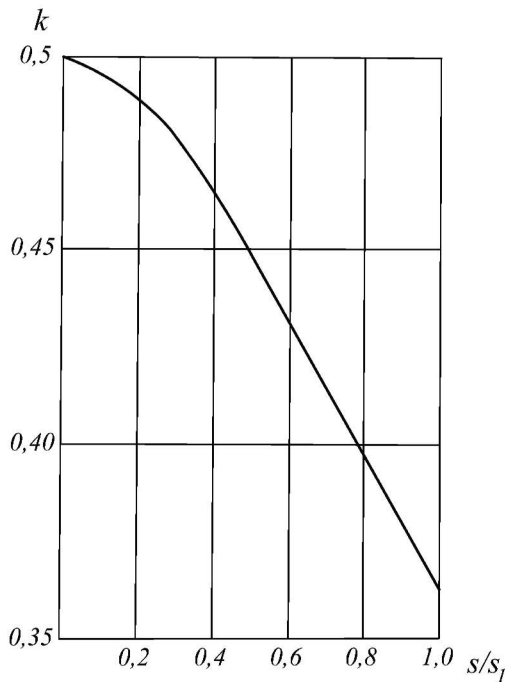

Fig. 2.5.1

2.5.2 The ligament efficiency factor of the tube plate at $0,75 > d/a > 0,4$ and $D_B/s_1 \geq 40$ shall be determined by the following formulae:

for spacing of holes on an equilateral triangle

$$\varphi = 0,935 - 0,65d/a ; \quad (2.5.2-1)$$

for unstaggered and staggered spacing of holes

$$\varphi = 0,975 - 0,68d/a_2 \quad (2.5.2-2)$$

where d = diameter of the hole in the tube plate, mm;
 a = pitch between hole centres for spacing of holes on an equilateral triangle, mm;
 a_2 = the lesser pitch for unstaggered or staggered spacing of holes (including concentric rows of holes), mm.

2.5.3 Ratio of dimensions of the tube plates d/a and D_B/s_1 shall be within the range specified in 2.5.2. The ratio $d/a = 0,75 \div 0,80$ may be admitted, but in this case the thickness of the tube plates, calculated by Formula (2.5.1), shall also satisfy the following condition:

$$f_{\min} \geq 5d \quad (2.5.3)$$

where f_{\min} = minimum permissible cross-sectional area of the tube plate portion between holes, mm².

2.5.4 The thickness of tube plates with expanded tubes, apart from Formula (2.5.1), shall satisfy the following condition:

$$s_1 = 10 + 0,125d . \quad (2.5.4)$$

The expansion joints of tube plates shall also satisfy the requirements of 2.10.2.2, 2.10.2.3 and 2.10.2.4.

2.5.5 If the tube plates are reinforced by means of welded-on or expanded tubes in such a way that the requirements of 2.10 are satisfied, the calculations for such tube plates may be made according to 2.4.

2.6 DISHED ENDS

2.6.1 Dished ends, unpierced or pierced, subject to internal or external pressure (Fig. 2.6.1) shall have a thickness s , in mm, not less than

$$s = \frac{D_a p y}{4 \sigma \varphi} + c \quad (2.6.1)$$

where p = design pressure (refer to 2.1.2), MPa;
 D_a = outside diameter of the end, mm;
 φ = efficiency factor (refer to 2.1.6);
 σ = allowable stress (refer to 2.1.4.6), MPa;
 y = shape factor selected from Table 2.6.1 depending on the ratio of the height to the outside diameter and on the nature of weakening of the end.

For elliptical and torispherical ends R_B is the maximum radius of curvature. For intermediate values of h_a/D_a and $d/\sqrt{D_a s}$ the shape factor y is determined by interpolation.

The flanged area of the end is assumed to commence at a distance of not less than $0,1D_a$ from the outside outline of the cylindrical portion (refer to Fig. 2.6.1). To choose y using Table 2.6.1 the value s shall be selected from a number of standard thicknesses. The finally accepted value s shall not be less than that determined by Formula (2.6.1);

c = allowance to be taken equal to:
 2 mm at internal pressure and
 3 mm at external pressure.

At wall thickness exceeding 30 mm the above allowance values may be reduced by 1 mm;

d = the larger dimension of the non-reinforced opening, mm.

The symbols for dished end elements are shown in Fig. 2.6.1.

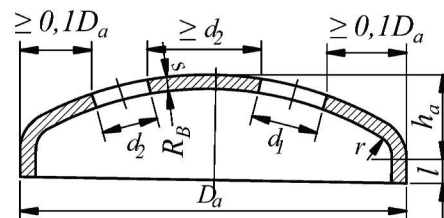

Fig. 2.6.1

2.6.2 Formula (2.6.1) is valid where the following relations are observed:

$$h_a/D_a \geq 0,18;$$

Table 2.6.1

Dished end shape	$\frac{h_a}{D_a}$	Shape factor y							y_0 — for dished part of end with reinforced openings
		y — for flanged area of end and for unpierced ends	y_A — for dished part of end with non-reinforced openings, for which $d/\sqrt{D_a s}$ is equal to:						
			0,5	1,0	2,0	3,0	4,0	5,0	
Elliptical or torispherical, with $R_B = D_a$	0,20	2,9	2,9	2,9	3,7	4,6	5,5	6,5	2,4
Elliptical or torispherical, with $R_B = 0,8D_a$	0,25	2,0	2,0	2,3	3,2	4,1	5,0	5,9	1,8
Hemispherical, with $R_B = 0,5D_a$	0,50	1,1	1,2	1,6	2,2	3,0	3,7	4,35	1,1

$$(s - c)/D_a \geq 0,0025;$$

$$R_B \leq D_a; \quad r \geq 0,1D_a;$$

$$l \leq 150 \text{ mm};$$

$$l \geq 25 \text{ mm} \quad \text{at } s \leq 10 \text{ mm};$$

$$l \geq 15 + s \quad \text{at } 10 < s \leq 20 \text{ mm};$$

$$l \geq 25 + 0,5s \quad \text{at } s > 20 \text{ mm}.$$

2.6.3 By unpierced end is meant an end, which has no openings or one with openings located at a distance of not less than $0,2D_a$ from the outside outline of the cylindrical portion and measuring not more than $4s$ in diameter and never more than 100 mm. In the flanged area of the end, non-reinforced openings are allowed, with diameters less than the wall thickness but not more than 25 mm.

2.6.4 The wall thickness of dished ends in combustion chambers of vertical boilers may be calculated as for unpierced ends, also where the flue-gas outlet branch passes through the end.

2.6.5 Dished ends subject to external pressure, except for those of cast iron, shall be checked for stability by calculation based on the following relation:

$$\frac{36,6E_t}{R_B^2} \frac{(s - c)^2}{100p} > 3,3 \quad (2.6.5)$$

where E_t = modulus of elasticity at design temperature, MPa;
for modulus of elasticity for steel, refer to Table 2.6.5;
for non-ferrous alloys, values of E_t shall be agreed with the Register;

Table 2.6.5

Design temperature t , °C	Modulus of elasticity for steel E_t , MPa
20	$2,06 \cdot 10^5$
250	$1,86 \cdot 10^5$
300	$1,81 \cdot 10^5$
400	$1,72 \cdot 10^5$
500	$1,62 \cdot 10^5$

R_B = maximum inside radius of curvature, mm.

Other symbols used are the same as in 2.6.1.

2.6.6 The minimum wall thickness of steel dished ends shall not be less than 5 mm. For ends manufactured from non-ferrous alloys and stainless steels, the minimum wall thickness may be reduced on agreement with the Register.

2.6.7 Where the results of a calculation made according to 2.9.2 call for the reinforcement of openings in dished ends, the reinforcement shall be made in compliance with the requirements of 2.9.3.

2.7 FLANGED END PLATES

2.7.1 Unpierced flanged end plates (refer to Fig. 2.7.1) subject to internal pressure shall have a thickness s , in mm, not less than

$$s = (3pD)/\sigma + c \quad (2.7.1)$$

where p = design pressure (refer to 2.1.2), MPa;
 D = inside diameter of the end plate flange to be equal to the inside diameter of the shell, mm;
 σ = allowable stress (refer to 2.1.4.6), MPa;
 c = allowance (refer to 2.1.7), mm.

In Fig. 2.7.1, l is the distance, in mm, from the inside diameter edge to the centre line of holding bolts.

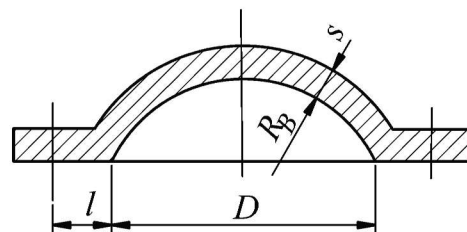

Fig. 2.7.1

2.7.2 Flanged end plates are allowed within the range of diameters up to 500 mm and for working pressures not more than 1,5 MPa. The radius of curvature R_B of the end plate shall not be more than $1,2D$, and the distance l not more than $2s$.

2.8 HEADERS OF RECTANGULAR SECTION

2.8.1 The wall thickness s , in mm, of rectangular headers (Fig. 2.8.1-1) subject to internal pressure shall not be less than that determined by the following formula:

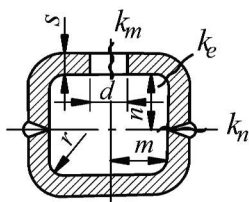

Fig. 2.8.1-1

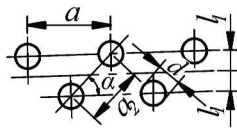

Fig. 2.8.1-2

$$s = \frac{pn}{2,52\sigma\varphi_1} + \sqrt{\frac{4,5kp}{1,26\sigma\varphi_2}} \tag{2.8.1-1}$$

where p = design pressure (refer to 2.1.2), MPa;
 n = half the width in the clear of the header side normal to that being calculated, mm;
 σ = allowable stress (refer to 2.1.4.6), MPa;
 φ_1 and φ_2 = efficiency factors of headers, weakened by holes determined as follows:
 φ_1 = by Formula (2.1.6.2.1);
 φ_2 = by Formula (2.1.6.2.1) at $d < 0,6m$; at $d \geq 0,6m$ by the following formula:

$$\varphi_2 = 1 - 0,6m/a \tag{2.8.1-2}$$

where m = half the width in the clear of the header side being calculated, mm;
 where the holes are arranged in a staggered pattern, a_2 (Fig. 2.8.1-2) shall be substituted for a in Formula (2.8.1-2);
 where the rectangular headers have longitudinal welded joints (refer to Fig. 2.8.1-1), the efficiency factors φ_1 and φ_2 are assumed to be equal, respectively, to the efficiency factor of welded joints selected as per 2.1.6. Longitudinal welded joints shall be arranged, as far as possible, within the area l_1 for which $k = 0$;
 where the header wall is weakened in several different ways, the calculations shall be based on the lowest efficiency factor value;
 k = design factor for bending moment at the centre of the side wall or at the centre line of the row of holes, mm^2 , determined by the formulae:

for the centre line of the header wall

$$k = \frac{1}{3} \frac{m^3 + n^3}{m+n} - \frac{m^2}{2}; \tag{2.8.1-3}$$

for rows of holes or longitudinal welded joints

$$k = \frac{1}{3} \frac{m^3 + n^3}{m+n} - \frac{m^2 + l_1^2}{2}. \tag{2.8.1-4}$$

If the above formulae yield negative values, the absolute numerical values shall be used;
 where the holes are arranged in a staggered pattern, factor k shall be multiplied by $\cos \alpha$;
 α = angle of the diagonal pitch to the longitudinal axis, deg.;
 l_1 = distance between the row of holes under consideration and the centre line of header wall (refer to Fig. 2.8.1-2), mm;
 d = diameter of the hole, mm.

For oval holes, d shall be taken as equal to the size of the holes on the longitudinal axis, but in Formulae (2.1.6.2.1) and (2.8.1-2) the size on the axis normal to the header centre line shall be taken as d for oval holes.

2.8.2 Where fillet welded joints are allowed in headers on agreement with the Register, the wall thickness of such headers shall not be less than

$$s = \frac{p\sqrt{m^2 + n^2}}{2,52\sigma\varphi_1} + \sqrt{\frac{4,5k_e p}{1,26\sigma\varphi_2}} \tag{2.8.2-1}$$

where k_e = design factor for bending moment at the edges, mm^2 , determined by the following formula:

$$k_e = \frac{1}{3} \frac{m^3 + n^3}{m+n}. \tag{2.8.2-2}$$

Other symbols used are the same as in 2.8.1.

2.8.3 The radius of curvature of rectangular header side shall not be less than 1/3 of the wall thickness and never less than 8 mm. The minimum thickness of header walls designed to accommodate expanded tubes shall not be less than 14 mm. The width of ligaments between holes shall not be less than 0,25 times the pitch between hole centres. The wall thickness in the area of curvature shall not be less than that determined by Formulae (2.8.1-1) and (2.8.2-1).

2.9 REINFORCEMENT OF OPENINGS IN CYLINDRICAL, SPHERICAL, CONICAL WALLS AND IN DISHED ENDS

2.9.1 General.

2.9.1.1 For the purpose of the present Rules openings are subdivided into the following types:

.1 openings reinforced by means of welded-on disc-shaped reinforcing plates (refer to Fig. 2.9.1.1.1);

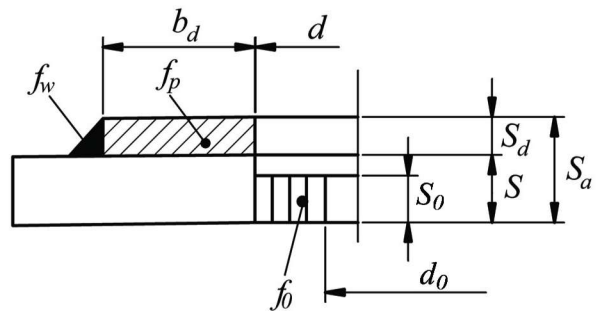

Fig. 2.9.1.1.1

.2 openings reinforced by means of welded-on tubular elements such as nozzles, sleeves, branch pieces, flanging, etc (refer to Figs. 2.9.1.1.2-1 to 2.9.1.1.2-3);

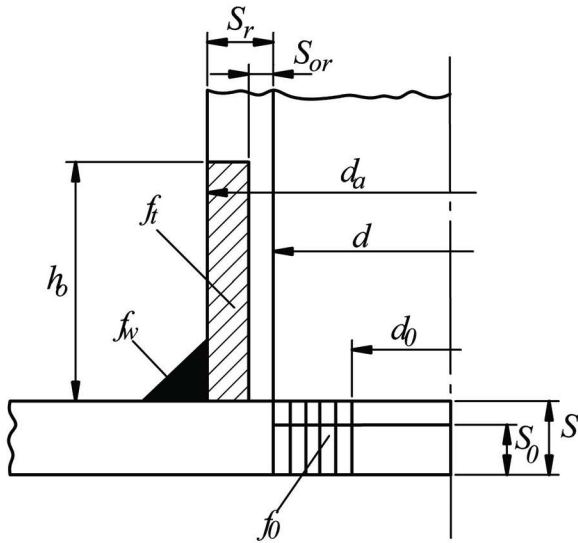

Fig. 2.9.1.1.2-1

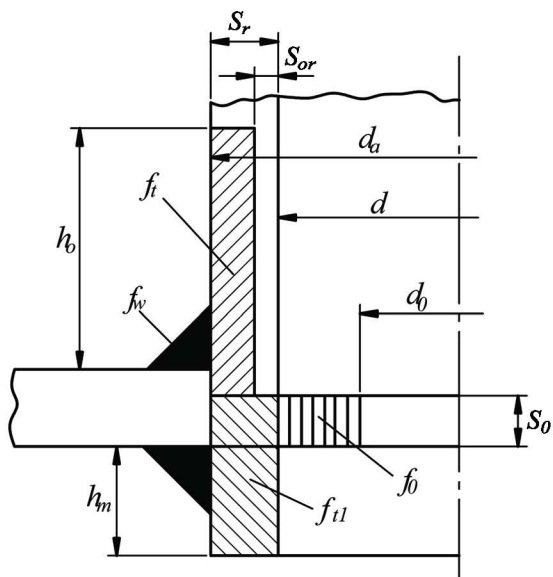

Fig. 2.9.1.1.2-2

.3 openings reinforced by combinations of reinforcing elements listed above (refer to Fig. 2.9.1.1.3);

.4 openings having no reinforcing elements (nozzles, sleeves, branch pieces, flanging and welded-on disc-shaped reinforcing plates), i.e. non-reinforced openings. The dimensions of non-reinforced openings shall not exceed those given in 2.9.2.

2.9.1.2 The materials used for the wall to be reinforced and for reinforcing elements shall have identical strength characteristics as far as possible. Where reinforcing materials with inferior strength

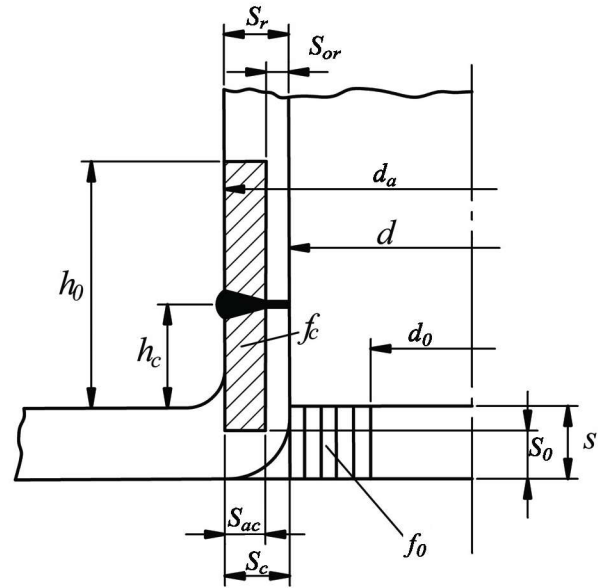

Fig. 2.9.1.1.2-3

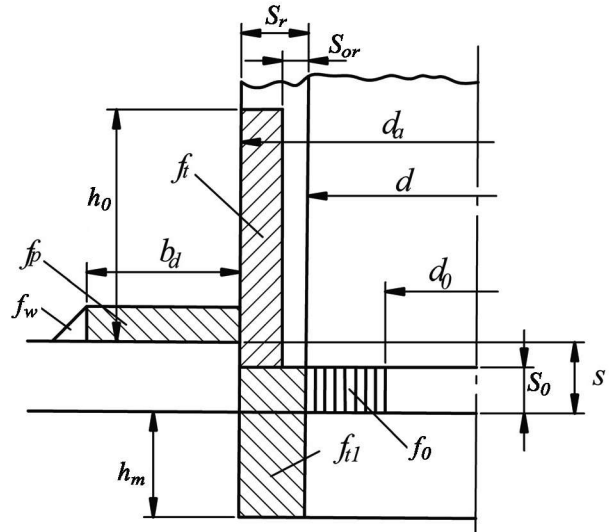

Fig. 2.9.1.1.3

characteristics compared to those of the wall to be reinforced are used, the area of reinforcing sections shall be increased proportionally to the ratio of permissible material stress of the wall to be reinforced to that of the reinforcing material. The higher strength of the reinforcing element shall be neglected.

2.9.1.3 As a rule, openings in walls shall be located at the distance of at least $3s$ (where s is the thickness of the wall to be reinforced), but not less than 50 mm away from welded joints. If the distance of the arrangement of openings away from welded joints is less than specified above, the efficiency factor shall be taken in accordance with 2.1.6.4.

2.9.1.4 The minimum thickness of reinforcing tubular elements (branch pieces, sleeves, nozzles) attached by welding to the walls of boilers, heat exchangers or pressure vessels shall be generally taken not less than 5 mm.

2.9.1.5 The maximum thickness of a tubular element or reinforcing plate taken in the reinforcement calculation shall not generally exceed the thickness of the wall to be reinforced.

The use of reinforcing elements with a thickness up to two thicknesses of the wall to be reinforced may be accepted if required by technological process, but such an increased thickness is disregarded in the reinforcement calculation.

2.9.2 The maximum permissible diameter of a non-reinforced opening.

A single opening is an opening, the edge of which is at a distance of at least $2Q$ from the edge of the nearest opening (where Q is the width of the mostly local opening affected zone, determined by Formula (2.1.6.4)).

The maximum permissible diameter of a single non-reinforced opening in cylindrical, spherical and conical walls and dished ends is determined by the formula

$$d_0 = (2/[\varphi_{in}] - 1,75)Q \quad (2.9.2-1)$$

where Q = the width of the mostly local opening affected zone determined by Formula (2.1.6.4);

$[\varphi_{in}]$ = minimal permissible efficiency factor value of a component weakened by opening, equal to:
for cylindrical wall

$$[\varphi_{in}] = \frac{P(D_a - s + c)}{2(s - c)\sigma}; \quad (2.9.2-2)$$

for ellipsoidal, torospherical and semi-spherical ends

$$[\varphi_{in}] = \frac{P(D^2/2h_a + s - c)}{4(s - c)\sigma}; \quad (2.9.2-3)$$

for conical walls

$$[\varphi_{in}] = \frac{P(D_c + s - c)}{2(s - c)\sigma \cos \alpha} \quad (2.9.2-4)$$

where D_a , D = outside and inside diameter of the wall to be reinforced, in mm, respectively;

D_c = inside diameter of large base of the conical wall, in mm;

σ = permissible stress, in MPa;

h_a = height of the dished part of end, in mm;

α = cone angle equal to half the angle at the conical wall vertex, in deg;

s = wall thickness, in mm;

c = corrosion allowance, in mm, taken according to 2.1.7.

2.9.3 Reinforcement of openings.

2.9.3.1 When reinforcing single openings in cylindrical, conical walls and dished ends, the sum

of compensating areas of reinforcements Σ_f shall exceed the required area of reinforcement f_0 :

$$\Sigma_f = f_i + f_{i1} + f_p + f_w + f_c > f_0 \quad (2.9.3.1)$$

where f_i and f_{i1} = compensating areas of exterior and interior parts of a tubular reinforcing element (refer to Figs. 2.9.1.1.2-1, 2.9.1.1.2-2, 2.9.1.1.2-3, 2.9.1.1.3), determined according to 2.9.3.2;

f_p = compensating area of disc-shaped reinforcing plate (refer to Figs. 2.9.1.1.1, 2.9.1.1.3), determined according to 2.9.3.3;

f_w = total compensating area of welded joints equal to the sum of deposited areas without regard weld reinforcement, mm²;

f_c = compensating area of flanged collar metal (refer to Fig. 2.9.1.1.2-3), determined according to 2.9.3.4;

f_0 = minimum required area of reinforcement, determined according to 2.9.3.5.

2.9.3.2 Compensating areas of tubular elements (nozzles) are determined by the following formulae:

for exterior part of a tubular reinforcing element

$$f_i = 2h_0(s_r - s_{or} - c), \text{ mm}^2; \quad (2.9.3.2-1)$$

for interior part of a tubular reinforcing element

$$f_{i1} = 2h_m(s_r - c), \text{ mm}^2, \quad (2.9.3.2-2)$$

where s_r = wall thickness of a tubular element, in mm, taken according to the drawing with consideration for recommendations of 2.9.1.5 and 2.9.1.6;

s_{or} = minimum design wall thickness of a tubular element determined according to 2.2.1.2 at $\varphi = 1,0$ and $c = 0$, in mm;

c = corrosion allowance, in mm (refer to 2.1.7);

h_0 = height of the exterior part of a tubular element, mm which shall be taken according to the drawing in case it does not exceed the value determined by the formula

$$h_0 = 1,25\sqrt{(d_a - s_r)(s_r - c)} \quad (2.9.3.2-3)$$

where d_a = outside diameter of a tubular element, in mm;

h_m = height of the interior part of a tubular element, which shall be taken according to the drawing in case it does not exceed the value determined by the formula

$$h_m = 0,5\sqrt{(d_a - s_r)(s_r - c)}. \quad (2.9.3.2-4)$$

2.9.3.3 Compensating areas of a disc-shaped reinforcing plate are determined by the formula

$$f_p = 2b_d s_d \quad (2.9.3.3)$$

where s_d = thickness of disc-shaped plate taken according to the drawing and with consideration for the requirements of 2.9.1.6;

b_d = a reinforcing plate width (refer to Figs. 2.9.1.1.1 and 2.9.1.1.3), which shall be taken according to the drawing but shall not exceed the width of the mostly opening affected area, Q , determined according to 2.1.6.4.

2.9.3.4 The compensating area of the flanged collar metal (refer to Fig. 2.9.1.1.2-3) is determined by the formula

$$f_c = 2h_{c1}(s_c - s_{oc} - c) + 2(h_0 - h_c)(s_r - s_{or} - c) \quad (2.9.3.4-1)$$

where h_0 , c , s_{or} , s_r = the same as for Formula (2.9.3.2-2);

h_{c1} = height of collar taken equal to the dimension according to the drawing but not more than

$$h_c \leq 0,5\sqrt{(d-s_c)(s_c-c)} \quad (2.9.3.4-2)$$

where s_c = thickness of the extended throat or flanged collar taken according to the drawing but not more than wall thickness s , in mm;

s_{oc} = the minimal design wall thickness of a collar or expanded throat, in mm, determined by the formula

$$s_{oc} = \frac{P(d+0,25r)}{2\sigma - P} \quad (2.9.3.4-3)$$

where r = curvature radius of a collar or throat, which shall be taken according to the drawing but shall not be less than 5 mm;

d = diameter of an opening to be reinforced, in mm.

2.9.3.5 The minimum required area of a reinforcement f_0 is determined by the formula

$$f_0 = (d - d_0)s_0 \quad (2.9.3.5)$$

where s_0 = the minimum required design wall thickness at $\phi = 1$ and $c = 0$ determined according to 2.2.1.2, 2.2.1.3, 2.3.1 and 2.6.1. In calculation of wall thickness s_0 by Formula (2.6.1), the value y_a obtained from Table 2.6.1 shall be substituted for y .

d_0 = the maximum permissible diameter of an isolated non-reinforced opening, in mm (refer to 2.9.2-1);

d = diameter of an opening to be reinforced, in mm.

2.9.3.6 In case where combined reinforcing elements are used (refer to Fig. 2.9.1.1.3) the condition of strength according to Formula (2.9.3.1-1) shall be satisfied and the dimensions of reinforcing elements shall meet the requirements of 2.9.1.6 to 2.9.1.7.

2.9.4 Interdependence of openings.

2.9.4.1 The interdependence of openings shall be taken into account if the distance between the edges of adjacent openings determined according to the drawing (refer to Fig. 2.9.4.1) is smaller than two Q , that is the following condition shall be satisfied:

$$l + s_{r1} + s_{r2} \geq 2Q \quad (2.9.4.1-1)$$

where Q = width of the mostly local opening affected zone determined by Formula (2.1.6.4).

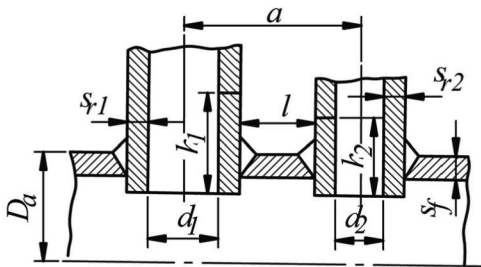

Fig. 2.9.4.1-1

If the above condition (2.9.4.1-1) is not satisfied, it is necessary to check the stress occurring in the section between the openings due to design pressure. The stress involved shall not exceed, both longi-

tudinally and transversely, the allowable values according to the relation

$$F/f_c \leq \sigma \quad (2.9.4.1-2)$$

where σ = allowable stress (refer to 2.1.4.6), in MPa;

F = load caused by the design pressure upon the section between the openings (refer to 2.9.4.2), in N;

f_c = design sectional area between the openings (refer to 2.9.4.3), in mm².

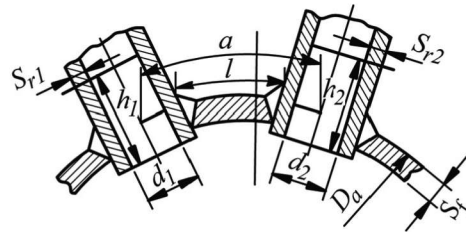

Fig. 2.9.4.1-2

2.9.4.2 The load caused by the design pressure, in N, affecting the section between two openings shall be determined as follows:

.1 for openings arranged longitudinally along a cylindrical wall

$$F_a = Dpa/2; \quad (2.9.4.2.1)$$

.2 for openings arranged circumferentially in cylindrical or conical walls as well as for openings in spherical walls

$$F_b = Dpa/4; \quad (2.9.4.2.2)$$

.3 for openings in dished ends

$$F_b = Dpya/4 \quad (2.9.4.2.3-1)$$

where D = inside diameter (for conical walls measured at the centre of the opening), mm;

p = design pressure (refer to 2.1.2), MPa;

y = shape factor (refer to 2.6.1);

a = pitch between two adjacent openings on the circumference (determined on the outside of the wall as shown in Fig. 2.9.4.1-2), mm.

Where openings are arranged in cylindrical walls at a diagonal pitch, the load involved is determined by Formula (2.9.4.2.2), the results being multiplied by a factor

$$k = 1 + \cos^2 \alpha \quad (2.9.4.2.3-2)$$

where α = angle of inclination of the line through the opening centres to the longitudinal axis, deg.

2.9.4.3 The design sectional area f_c , in mm², between two adjacent openings with tubular reinforcements shall be determined by the following formula:

$$f_c = k(s - c) + 0,5[h_1(s_{r1} - c) + h_2(s_{r2} - c)] \quad (2.9.4.3)$$

where h_1 and h_2 = heights of the reinforcement, mm, determined by the following formulae:

$h_1(h_2) = h_0 + s$ for non-through reinforcements and
 $h_1(h_2) = h_0 + s + h_m$ for through reinforcements;
 l = width of the ligament between two adjacent reinforcements (refer to Figs. 2.9.4.1-1 and 2.9.4.1-2), mm;
 s = thickness of the wall to be reinforced, mm;
 s_{r1} and s_{r2} = thicknesses of the tubular reinforcements (refer to Figs. 2.9.4.1-1 and 2.9.4.1-2), mm;
 c = allowance (refer to 2.1.7), mm;
 h_0 = design height of the tubular reinforcement (refer to Formula (2.9.3.2-3));
 h_m = height of inward projecting portion of the tubular reinforcement (refer to Formula (2.9.3.2-4)), mm.

For openings to be reinforced by other methods (combined or disc-shaped reinforcements, etc.) the design sectional area f_c shall be determined in a similar manner.

2.10 STAYS

2.10.1 Scantlings of stays.

2.10.1.1 The cross-sectional area f , in mm², of long and short stays, corner stays and stay tubes subject to tensile or compressive stresses shall not be less than

$$f = pf_s / (\sigma \cos \alpha) \quad (2.10.1.1)$$

where p = design pressure (refer to 2.1.2), MPa;
 σ = allowable stress (refer to 2.1.4.6), MPa;
 α = angle between the corner stay and the wall, to which the stay is attached (refer to Fig. 2.4.2.1-3), deg.;
 f_s = maximum surface area per stay of the wall to be reinforced, bounded by lines passing at right angles through the centres of the lines joining the centre of the stay with the adjacent points of support (stays), mm².
 The cross-sectional area of the stays and tubes within this area may be deducted from the surface area per stay.

2.10.1.2 For stays subject to longitudinal bending, the allowable bending stresses shall be taken with a safety factor not less than 2,25.

2.10.1.3 For end plates with a separate reinforcing stay (Fig. 2.10.1.3), the latter shall be so designed that it may take up at least half the load upon the end plate. An end plate of this type shall have a thickness in compliance with the requirements of 2.4.2.1.

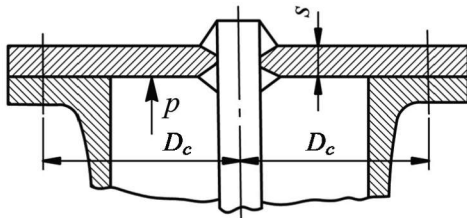

Fig. 2.10.1.3

2.10.1.4 Stay and ordinary fire tubes shall have a thickness not lower than that indicated in Table 2.10.1.4.

Table 2.10.1.4

Outside diameter of tube, mm	Working pressure p , MPa, at wall thickness, mm			
	3,0	3,5	4,0	4,5
50	1,1	1,85	—	—
57	1,0	1,65	—	—
63,5	0,9	1,5	2,1	—
70	0,8	1,35	1,9	—
76	0,75	1,25	1,75	2,25
83	—	1,15	1,6	2,1
89	—	1,05	1,5	1,9

The thickness of stay tubes with diameters over 70 mm shall not be less than:

6 mm for peripheral tubes;

5 mm for tubes arranged inside the tube nest.

2.10.2 Attachment of stays.

2.10.2.1 The cross-sectional area of welded joints of welded-on stays shall be such as to satisfy the following condition:

$$\pi d_a e / f \geq 1,25 \quad (2.10.2.1)$$

where d_a = stay diameter (for tubes — outside diameter), mm;
 e = weld thickness (Figs. 5.1 to 5.3 of the Appendix), mm;
 f = cross-sectional area of the stay (refer to 2.10.1.1), mm².

2.10.2.2 For expanded tubes the length of the expansion joint in the tube plate shall not be less than 12 mm.

Expansion joints for working pressures above 1,6 MPa shall be made with sealing grooves.

2.10.2.3 Expansion joints shall be checked for secure seating of the tubes in the tube plates by axial testing loads. The tubes may be considered securely seated, if the inequality is effected

$$pf_s / 20sl \leq A \quad (2.10.2.3)$$

where A is equal to:
 15 for joints of plain tubes;
 30 for joints with sealing grooves;
 40 for joints with flanging of tubes;
 s = thickness of the tube wall, mm;
 p and f_s refer to 2.10.1.1;
 l = length of the expansion belt, mm.
 l shall be taken as not more than 40 mm.

2.10.2.4 The expansion of the plain tubes shall ensure secure seating of the tubes $q \geq 250$ N/mm according to the formula

$$q = F / l \quad (2.10.2.4-1)$$

where q = secure seating of the tube in the opening per 1 mm of the expansion belt length, N/mm; in case of automatic expansion, this value shall be taken as 250 N/mm; in other cases, it shall be obtained experimentally. Where lower values are obtained, the thickness of the tube plate shall be proportionally increased;

F = tension necessary for rupture of the expansion joint, N;

l = expansion belt length, in mm, which shall not be less than that determined by the formula

$$l = pf_s k_r / q \quad (2.10.2.4-2)$$

where k_r = safety factor for the expansion joint, which shall be taken as 5,0.

Other symbols used are the same as in 2.10.1.1.

2.11 TOP GIRDERS

2.11.1 The section modulus W , in mm^3 , of top girders of rectangular section shall not be less than

$$W = 1000M / (1,3\sigma z) \quad (2.11.1-1)$$

where σ = allowable stress (refer to 2.1.4.6), MPa;
 z = coefficient of rigidity of the wall to be reinforced; for the structure shown in Fig. 2.11.1, $z = 1,33$;
 M = bending moment of the girder, N·m;

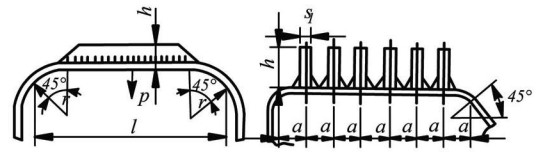

Fig. 2.11.1

for a rectangular section

$$M = pa^2 / 8000 ; \quad (2.11.1-2)$$

s_1 = width of the girder, mm;
 h = height of the girder, which shall not be more than $8s_1$, mm;
 l = design length of the girder, mm;
 p = design pressure (refer to 2.1.2), MPa;
 a = spacing of girders, mm.

3 BOILERS

3.1 GENERAL

3.1.1 The general provisions concerning surveys, technical documentation, manufacture, materials and general requirements for boilers and also strength calculation standards for boiler elements are set forth in Sections 1 and 2.

3.1.2 The boilers shall remain operative under the environmental conditions specified in 2.3, Part VII "Machinery Installations".

3.1.3 Where the failure of an auxiliary boiler for essential services involves the stop of main engine or ship deenergizing or results in the deviation from the specified requirements for proper carriage of goods, two boilers may be required by the Register, the capacity of each being sufficient to ensure normal ship operation.

3.1.4 The manufacturer shall provide operating instructions for each economizer which shall include reference to:

- .1** feed water treatment and sampling arrangements;
- .2** operating parameters: pressure, exhaust gas and feed water temperatures;
- .3** inspection and cleaning procedures, records of maintenance and inspection;
- .4** the need to maintain adequate water flow through the economizer under all operating conditions;
- .5** periodical operational checks of the safety devices to be carried out by the operating personnel and to be documented accordingly;
- .6** procedures for using the exhaust gas economizer in the dry condition;
- .7** procedures for maintenance and overhaul of safety valves.

3.2 CONSTRUCTION REQUIREMENTS

3.2.1 The thickness of tube walls thinned in the process of bending shall not be less than the design values.

3.2.2 The use of long and short stays shall be avoided, and also that of stay tubes exposed to bending or shearing stresses. Stays, strength walls, reinforcements, etc. shall have no abrupt changes in cross-sections.

Control drilled holes shall be provided for at short-stay ends as shown in Fig. 5.3 of the Appendix.

3.2.3 For walls reinforced by short stays and exposed to flame and high-temperature gases, the distance between stay centres shall not be larger than 200 mm.

3.2.4 Corner stays of gas-tube boilers shall be arranged at a distance of not less than 200 mm from the furnaces flues. Where flat walls are reinforced with welded-on girders, this shall be done so that the load involved is transferred as far as possible to the boiler shell or the most rigid parts.

3.2.5 The distance between furnaces flues and boiler shell shall not be less than 100 mm. The distance between any two furnaces shall not be less than 120 mm.

3.2.6 Branches and nozzles shall be of rigid construction and minimum length sufficient for fixing and dismantling boiler valves without removing the insulation. Branch pieces shall not be subjected to excessive bending stresses and shall be reinforced by stiffening ribs if so required.

3.2.7 Pads intended for installation of valves and pipes as well as branches, sleeves and nozzles passing through the entire thickness of the boiler wall shall generally be attached by welding from both sides. Branches and nozzles may also be fillet welded, with single-edge preparation, using removable backing strip, or by some other method that ensures penetration throughout the thickness of the part being attached.

3.2.8 Boiler drums and headers having a wall thickness greater than 20 mm and also superheater headers shall be protected from direct heat radiation as indicated in 2.1.3.4. The heating surface components of boilers and oil burner unit tuyeres subject to direct heat radiation shall have no projecting portions or edges on the fire side.

3.2.9 Where use is made of non-metal sealing gaskets, manhole and handhole closures shall be so designed as to prevent the possibility of the gasket being forced out.

3.2.10 Manholes, sight holes and other openings in boiler walls shall be reinforced as specified in 2.4.4 and 2.9.

3.2.11 Structural measures shall be taken to prevent steam generation in economizers of boilers.

3.2.12 A nameplate indicating all principal technical data of boilers shall be provided in a conspicuous place.

3.2.13 The fastening elements of the boiler, apart from those which are not stressed, shall not be attached by welding directly to the boiler walls (shell, ends, headers, drums, etc.) but shall be attached by means of welded-on plates.

3.2.14 The tubes securely seated in the headers and tube plates by expansion of their ends shall be seamless.

3.2.15 Water-tube finned-tube boilers and all waste-heat boilers with forced circulation shall be equipped with an effective fire-resistant soot-cleaning system and their heating surfaces shall have access for inspection and cleaning as well as for sediments removal.

3.2.16 Waste-heat boilers with forced circulation connected to exhaust gas systems of two stroke diesels with inlet gas temperature of 270 °C and lower shall meet the following requirements:

.1 hydraulic resistance of the boiler gas duct shall be such that during operation the gas flow velocity at the pipes of heating surfaces is not less than 10 m/s;

.2 for disconnection of the boiler heating when the engine is operated at partial loads the automated or remotely controlled arrangement providing full gas transfer shall be provided;

.3 the boilers shall be equipped with the system of washing and sediments removal. At the same time measures shall be taken to exclude washing products entering in the engine gas duct. It is advisable to use special additive-injection arrangements to facilitate removal of sediments from the heating surfaces.

3.2.17 The design of waste-heat boilers with forced circulation shall provide for the fixed fire-extinguishing systems to be connected, as stipulated in item 11 of Table 3.1.2.1, Part VI "Fire Protection".

3.2.18 Tube plate connections to the economizer shell shall be made with full penetration of the welded joints. After welding the connections shall be subjected to heat treatment and to 100 per cent radiographic and ultrasonic examination. Every shell type economizer shall be provided with removable lagging at the circumference of the tube end plates to enable ultrasonic examination of the tube plate to shell connection. The removable elements shall ensure measurements at least at 4 points located at mutually perpendicular midship lines. The requirements to economizer safety valves, means of steam pressure monitoring and quality of feed water are specified in 3.3.6 of the present Part and in 17.2.6, Part VIII "Systems and Piping", respectively.

3.3 VALVES AND GAUGES

3.3.1 General.

3.3.1.1 All boiler valves shall be fitted on special welded-on branches, nozzles and pads, and shall generally be secured thereto by studs or bolts. The studs shall have a full thread holding in the pad for a length of at least one external diameter.

The bore of threaded nozzle fitted mountings is allowed to be not greater than 15 mm, special pads being used for attaching them to the boiler.

The construction of pads, branches and nozzles shall comply with the requirements of 2.9.

3.3.1.2 The valve covers shall be secured to valve cases by studs or bolts. Valves with bore diameters of 32 mm and less may have screwed covers provided that they are fitted with reliable stops.

3.3.1.3 The valves and cocks shall be fitted with open and shut position indicators.

Position indicators are not required where the design allows to see without difficulty whether the valves are open or shut. All valves shall be arranged to be shut with a clockwise motion of the wheels.

3.3.2 Feed valves.

3.3.2.1 Each main boiler and each auxiliary boiler for essential services shall be equipped with at least two feed valves. Auxiliary boilers for other services, and also waste-heat boilers may have one feed valve each.

3.3.2.2 The feed valves shall be of a non-return type (check valves). A shut-off valve shall be installed between the check valve and the boiler. The check and shut-off valves may be housed in one casing. The shut-off valve shall be fitted directly on the boiler.

3.3.2.3 The requirements concerning the feed water system are given in Section 17, Part VIII "Systems and Piping".

3.3.3 Water level indicators.

3.3.3.1 Each boiler with free water evaporating surface shall be provided with at least two independent water level indicators with transparent faces (refer to 3.3.3.3). On agreement with the Register, one of these indicators need not be installed when provision is made on the boiler for the lowest water level protective devices, as well as the lowest and highest water level alarms (the transducers of protective and signalling systems shall be independent and shall have different measuring points), or for lowered or remote water level indicator of an approved type with separate measuring points.

Boilers with a steaming capacity of 750 kg/h and less as well as all steam-heated steam generators, waste-heat boilers with free water evaporating surface and steam headers of waste-heat boilers may be provided with one water level indicator having a transparent face.

3.3.3.2 Forced circulation boilers shall be provided, instead of water level indicators, with two independent alarms to signal a shortage of water supply to the boiler.

When the boiler is serviced by an automatic oil burner unit, complying with the requirement of 5.3.3.4, a second alarm is not required.

This requirement is not applicable to waste-heat boilers.

3.3.3.3 Flat prismatic glass shall be used in water level indicators for boilers having a working pressure of less than 3,2 MPa. For boilers having a working pressure of 3,2 MPa and upwards, sets of mica sheets shall be used instead of glass, or else plain glass with a mica layer to protect the glass from water and steam effects, or other materials resistant to destructive action of the boiler water.

3.3.3.4 The water level indicators shall be fitted on the front of the boiler, at an equal height and, as far as possible, at an equal distance from the vertical centre line of the drum/boiler shell.

3.3.3.5 All water level indicators shall be provided with shut-off devices both on the water and steam sides.

Shut-off devices shall have safe drives for disconnection of the devices in case of glass breakage.

3.3.3.6 Water level indicators shall have the possibility of separately blowing off the water and steam spaces. Blow-down ducts shall have an inside diameter of not less than 8 mm. The design of water level indicators shall prevent the gasket materials from being forced into the ducts, and allow of cleaning the blow-down ducts, as well as of replacing the glasses while the boiler is in operation.

3.3.3.7 Water level indicators shall be so installed that the lower edge of the gauge slot is positioned below the lowest water level in the boiler by not less than 50 mm, however, the lowest water level shall not be above the centre line of the visible portion of the water level indicator.

3.3.3.8 Water level indicators shall be connected to the boiler by means of independent branch pieces. No tubes leading to these branches are allowed inside the boiler. The branches shall be protected from exposure to hot gases, radiant heat and intense cooling. If the gauge glasses are fitted on the additional small vessels, the space inside such vessels shall be divided by partitions.

Water gauges and connecting pipes between them shall not be allowed to carry nozzles or branch pieces to be used for other purposes.

3.3.3.9 The branch pieces for attachment of water level indicators to boilers shall have an inside diameter not less than:

32 mm for bent branches of main boilers;

20 mm for straight branches of main boilers and for bent branches of auxiliary boilers;

15 mm for straight branches of auxiliary boilers.

3.3.3.10 The design, dimensions, number, location and lighting of water level indicators shall provide for adequate visibility and reliable control

of the boiler water level. Where water level visibility is inadequate, irrespective of the height of water level indicator location, or where the boilers are remotely controlled, provision shall be made for highly reliable remote water level indicators (placed at a lower position) or other types of water gauges approved by the Register and installed in the boiler control stations.

This requirement is not applicable to waste-heat boilers and their steam accumulators (steam separators).

3.3.3.11 Remote water level indicators for boilers may have a tolerance not exceeding ± 20 mm as compared to water level indications of gauge glasses fitted on the boiler while the relevant delays in level indications at the highest possible rate of change shall not exceed 10 per cent of difference between the upper and lower levels.

3.3.4 Lowest water level and highest heating-surface point.

3.3.4.1 Each natural circulation boiler with free water evaporating surface shall have its lowest water level marked on the boiler water level indicator with a reference line drawn on the gauge frame or body. Additionally, the lowest water level shall be marked on a plate with a reference line and an inscription "lowest level". The plate shall be attached to the boiler shell close to the water level indicators.

The reference line and the plate shall not be covered over with boiler insulation.

3.3.4.2 In all cases the lowest water level in the boiler shall not be less than 150 mm above the highest heating-surface point. This distance shall also be maintained when the ship is listed up to 5 degrees either side and under all possible service trim conditions.

In the case of boilers with design steaming capacity less than 750 kg/h, the said minimum distance between the lowest water level and the highest heating-surface point may be reduced down to 125 mm.

3.3.4.3 The position of the upper ends of the uppermost downcomers is assumed to be the highest point of the heating surface of water-tube boilers.

3.3.4.4 Gas-tube boilers shall be fitted with a position indicator for the highest heating-surface point, which shall be securely attached to the boiler wall, close to the lowest water-level plate, and to have an inscription "highest heating-surface point".

3.3.4.5 The requirements for the position of the highest heating-surface point and the relevant position indicator do not apply to waste-heat boilers, forced circulation boilers, economizers and steam superheaters.

3.3.5 Pressure gauges and thermometers.

3.3.5.1 Each boiler shall have at least two pressure gauges connected with the steam space by separate pipes fitted with stop valves or stop cocks. Three-way valves or cocks shall be provided between the pressure gauge and the pipe to make it possible to shut off the pressure gauge from the boiler, connect it to the atmosphere, blow off the connecting pipe and install the control pressure gauge.

3.3.5.2 One of the pressure gauges shall be installed on the front of the boiler, the other at the main engine control station.

3.3.5.3 Boilers with design steaming capacity below 750 kg/h and waste-heat boilers are allowed to have one pressure gauge.

3.3.5.4 A pressure gauge shall be provided at the water outlet from the economizer.

3.3.5.5 Pressure gauges shall have a scale sufficient to allow of boiler hydraulic testing. The pressure gauge scale shall have a red line to mark the working pressure in the boiler.

3.3.5.6 Pressure gauges fitted on boilers shall be protected from the heat emitted by the hot boiler surfaces.

3.3.5.7 The pressure gauges shall be calibrated by a competent body.

3.3.5.8 Steam superheaters and economizers shall be equipped with thermometers. Remote temperature control does not obviate the need for providing local thermometers.

3.3.5.9 A means of indicating the internal pressure of economizers shall be located so that the pressure can be easily read from any position from which the pressure can be controlled.

3.3.6 Safety valves.

3.3.6.1 Each boiler shall have not less than two spring-loaded safety valves of identical construction and equal size, to be installed on the drum, as a rule, on a common branch piece and one valve to be fitted on the superheater outlet header. The superheater safety valve shall be so adjusted as to open before the safety valve installed on the drum.

Safety valves of the impulsive action type are recommended for steam boilers having a working pressure of 4 MPa and more.

For steam boilers with design steaming capacity below 750 kg/h, steam headers and unfired steam generators only one safety valve may be permitted if the adequate protection against overpressure is confirmed by carrying out a risk assessment approved by the Register.

3.3.6.2 The aggregate cross-sectional area f , in mm², of safety valves shall not be less than:
for saturated steam

$$f = k \frac{G}{10,2p_w + 1}; \quad (3.3.6.2-1)$$

for superheated steam

$$f = k \frac{G}{10,2p_w + 1} \sqrt{\frac{V_H}{V_s}} \quad (3.3.6.2-2)$$

where G = design steaming capacity, kg/h;
 p_w = working pressure, MPa;
 V_H = specific volume of superheated steam at the appropriate working pressure and temperature, m³/kg;
 V_s = specific volume of saturated steam at the appropriate pressure, m³/kg;
 k = coefficient of hydraulic resistance is assumed to be equal to: d/h at $h/d \leq 0,25$; $1,25d/h$ at $h/d > 0,25$;
 d = minimum valve diameter, mm;
 h = height of valve lifting, mm.

Spring safety valves shall not be less than 32 mm and not more than 100 mm in diameter.

If specially approved by the Register, the use of valves with smaller cross-sectional areas than required by Formulae (3.3.6.2-1) and (3.3.6.2-2) may be allowed, provided it is proved experimentally that each of these valves has a discharge capacity not lower than the design steaming capacity of the boiler.

3.3.6.3 The cross-sectional area of the safety valve installed on the non-disconnectable superheater may be included in the aggregate cross-sectional area of the valves to be determined from Formulae (3.3.6.2-1) and (3.3.6.2-2). This area shall not amount to more than 25 per cent of the aggregate area of the valves.

3.3.6.4 The safety valves shall be so adjusted that the maximum pressure during their operation shall not exceed the working pressure by more than 10 per cent. When lifted, the safety valves of main and auxiliary boilers for essential services shall fully interrupt the outgoing steam flow in case of the pressure drop in the boiler not below 0,85 of the working pressure.

3.3.6.5 Economizers shall be provided with spring-loaded safety valves not less than 15 mm in diameter.

3.3.6.6 Where safety valves are fitted on a common branch, the cross-sectional area of the branch shall not be less than 1,1 times the aggregate cross-sectional area of the valves installed.

3.3.6.7 The cross-sectional area of the waste-steam branch of the safety valve and of the pipe connected thereto, shall not be less than twice the aggregate cross-sectional area of the valves.

3.3.6.8 To remove the water of condensation, a drain pipe without any stopping devices shall be provided for on the valve body or on the waste-steam pipe (if the latter is located below the valve).

3.3.6.9 The safety valves shall be connected directly to the boiler steam space without any stopping devices. Supply pipes leading to the safety valves are not allowed to be installed inside the

boiler. No provision shall be made on the safety valve bodies or their connections for steam extraction devices for other purposes.

3.3.6.10 The safety valves shall be so arranged that they can be lifted by a manual remote control gear as well as that powered from energy source. The remote control gear of one of the valves shall be operated from the boiler room, and of the other valve from any other readily accessible position outside the engine room.

The remote control gear for safety valves of steam superheaters, waste-heat boilers and their steam headers (separators) may be operated only from the boiler room.

3.3.6.11 The safety valves shall be so designed that they could be sealed or provided with an equivalent safeguard to prevent the valves from being adjusted without the knowledge of the operating personnel.

The springs of the safety valves shall be protected from direct exposure to steam and shall be manufactured from heat- and corrosion-resistant materials, as also are the sealing surfaces of seats and valves.

3.3.6.12 Safety valves of economizers shall comply with the following requirements:

.1 where a shell type economizer is capable of being isolated from the steam plant system, it shall be provided with at least one safety valve, and when it has a total heating surface of 50 m² or more, it shall be provided with at least two safety valves;

.2 to avoid the accumulation of condensate on the outlet side of safety valves, the discharge pipes and/or safety valve housings shall be fitted with drainage arrangements from the lowest part, directed with continuous fall to a position clear of the economizer where it shall not pose threats to either personnel or machinery. No valves or cocks are to be fitted in the drainage arrangements.

3.3.7 Shut-off and stop valves.

3.3.7.1 Each boiler shall be separated from all pipelines leading to it by means of shut-off valves secured directly to the boiler.

3.3.7.2 For continually attended in the engine room non-automated ships, shut-off stop valves shall be provided with remote control gears for the operation from other readily accessible position outside the engine room. The use of manual remote control gears as well as those powered from energy source is allowed.

For automated ships this requirement is considered to be advisory.

3.3.7.3 Where there is one main boiler or an auxiliary boiler for essential services installed on board the ship complete with a superheater or an economizer, the superheater and economizer shall be so arranged as to be shut off from the boiler.

3.3.7.4 The requirements for steam lines and boiler blow-down pipes are set forth in Section 18, Part VIII "Systems and Piping".

3.3.8 Blow-down valves.

3.3.8.1 Boilers, their steam superheaters, economizers and steam accumulators shall be fitted with blow-down arrangements and, where so required, with drain valves.

Blow-down and drain valves shall be fitted directly to the boiler shell. At working pressures below 1,6 MPa these valves may be installed on welded-on profiled branch pieces.

3.3.8.2 The inside diameter of blow-down valves and pipes shall not be less than 20 mm and not more than 40 mm. For boilers with design steaming capacity below 750 kg/h the inside diameter of the valves and pipes may be reduced to 15 mm.

3.3.8.3 In boilers with free water evaporating surface the scum arrangements shall ensure scum and sludge removal from the entire evaporating surface.

3.3.9 Salinometer valves.

Each boiler shall be provided with at least one salinometer valve or cock. The fitting of such valves or cocks on pipes and branches intended for other purposes is not allowed.

3.3.10 Valves for deaeration.

Boilers, steam superheaters and economizers shall be equipped with sufficient number of valves or cocks for deaeration.

3.3.11 Openings for internal inspection.

3.3.11.1 Boilers shall be provided with manholes for inspection of all internal surfaces. Where the provision of manholes is not possible, arrangements shall be made for hand holes.

3.3.11.2 Manhole openings shall have dimensions in the clear not less than 300 × 400 mm for oval openings, and 400 mm for round openings.

In separate cases, if specially approved by the Register, the dimensions of manhole openings may be reduced to 280 × 380 mm and to 380 mm for oval and round openings, respectively. The oval manholes in cylindrical shells shall be so positioned that the minor axis of the manhole is arranged longitudinally.

3.3.11.3 Vertical gas-tube boilers shall have at least two hand holes arranged in the shell opposite to each other in the area of the working water level.

3.3.11.4 All boiler parts such as may prevent or hinder free access to, and inspection of, internal surfaces shall be of a removable type.

3.4 INCINERATOR BOILERS

3.4.1 The present requirements apply to ship auxiliary boiler units used for burning garbage, oil residues and sludge having a flash point above 60 °C.

3.4.2 The strength calculations and requirements for design, valves, oil burning installations, control and protection are specified in Sections 2 to 5.

3.4.3 Control and monitoring systems of incinerator boilers designed for unattended operation and their elements shall satisfy the requirements of Part XV "Automation".

3.4.4 In order to burn garbage, oil residues and sludge, provision shall, as a rule, be made for a special chamber complying with the following requirements:

.1 the chamber shall be separated from the boiler furnace and shall be covered with refractory lining, which is not chemically affected by combustion products;

.2 the ducts connecting the furnace and the chamber shall have a sufficient cross-sectional area. In any case, the working pressure in the chamber shall not exceed the pressure in the furnace by more than 10 per cent;

.3 provision shall be made for a safety device set to operate when the working pressure is exceeded by more than 0,02 MPa. The safety device shall be so arranged that no flame ejection is possible into the engine and boiler room;

.4 the aggregate cross-sectional area of the safety device shall be at least 115 cm² per 1 m³ of the volume and not below 45 cm². Garbage may be burned in chambers located within the fire space of the boiler. Incinerator boilers shall be provided with a charging facility fitted with covers, which are so interlocked that they cannot be opened simultaneously. For incinerator boilers having no charging facility, provision shall be made for an interlock between the charging door being opened and the temperature in the combustion chamber so as to exclude the self-ignition of cargo during loading.

In case of any restrictions concerning the materials charged, this shall be indicated on a warning plate.

3.4.5 A specially designed system shall generally be used for burning of oil residues and sludge. The use of the boiler fuel supply system and oil burning installation is only permitted if smokeless combustion is ensured.

3.4.6 The incinerator boilers shall be provided with an effective system of soot removal.

3.5 THERMAL LIQUID BOILERS

3.5.1 The requirements of the present Chapter apply to thermal liquid boilers.

3.5.2 General provisions relating to surveys, technical documentation, construction, strength calculation standards and also general requirements are set forth in Sections 1 and 2 and in 3.2.1, 3.2.6 to 3.2.10, 3.2.12, 3.2.13.

Along with that, regardless of the working pressure, the minimum design pressure for thermal

liquid boilers shall be not less than 1,0 MPa and for the tanks containing the thermal liquid — not less than 0,2 MPa.

3.5.3 Boilers shall generally be installed in separate spaces provided with exhaust ventilation sufficient to give at least 6 air changes per hour.

In case of other arrangement, the place where the boilers are installed shall be fenced with welded on coaming of at least 150 mm in height, fitted with a drain pipe to an enclosed tank.

3.5.4 The boiler shall be designed so that no temperature increase of the tube wall on the thermal liquid side above the permissible value is possible in any part of the boiler.

3.5.5 Each boiler shall be equipped with:

.1 shut-off devices at the thermal liquid inlet and outlet;

.2 at least one spring-loaded safety valve of encased type. The total capacity of safety valves fitted shall be at least not less than the increment of the thermal liquid amount at the maximum heating intensity. Safety valves shall not be less than 25 mm and not more than 130 mm in bore diameter. The opening pressure of a safety valve shall not exceed the maximum working pressure by more than 10 %;

.3 pressure gauge;

.4 arrangement for complete emptying;

.5 manholes or hand holes for inspection of the furnace;

.6 manholes for inspection of the heating surface of a waste-heat boiler at the gas inlet and outlet;

.7 a nameplate provided in a conspicuous place according to 3.2.12;

.8 furnaces of auxiliary boilers and inlet chambers of waste-heat boilers shall be equipped with draining arrangements and thermal liquid leakage alarm.

3.5.6 Electrically heated boilers are subject to the same requirements as oil-fired boilers.

3.5.7 Each waste-heat boiler and oil-fired boiler shall be provided with an effective system of soot blow down.

3.5.8 Boiler tubes shall be attached to drums and headers by welding.

3.5.9 Boilers shall be equipped with valves having bellow seals.

3.5.10 Boilers shall be equipped with temperature sensors at the outlet of gases, fire alarms and limiting temperature protection at the outlet of thermal liquid.

3.5.11 Thermal liquid temperature on the outlet of the waste-heat boilers shall be controlled irrespective of the engines operation by changing the amount of exhaust gases or by-pass of the thermal liquid to the special cooler.

Use of dampers to control temperature in waste-heat boilers is permitted only for boilers with plain

tubes, provided the gas velocity therein is not less than 10 m/s.

A shut-off device shall be provided to stop gas supply to a waste-heat boiler in case of operation of protective devices which shall not interfere with the operation of the engine.

When one or two engines are installed on board the ship, this device may be omitted.

3.5.12 Thermal liquid boilers shall be provided with automatic combustion controls, visual and audible alarms in compliance with 4.3.10, Part XV "Automation", interlocking specified in 5.3.2 and protective devices according to 5.3.3.

Moreover, interlocking shall be provided for actuation of the burner units with the circulating pumps out of operation.

For waste-heat boilers, in case when these begin to be heated with the circulating pumps out of operation, alarm shall be provided.

3.5.13 Thermal liquid boilers shall be provided with a fixed fire extinguishing system. The use of drenching systems employing large quantities of water may be accepted. Gas duct under the waste-heat boiler shall be equipped with a drainage system used for carrying away such water in order to preclude penetration thereof into the engine.

4 CONTROLS, GOVERNORS, PROTECTIVE DEVICES AND ALARMS FOR BOILERS

4.1 GENERAL

4.1.1 The requirements of the present Section apply to continuously attended steam boilers and thermal fluid boilers.

Additional requirements for controls, governors, protective devices and alarms for boilers comprising unattended automated boiler plants are specified in 4.3, Part XV "Automation" and 4.2.3.1, Part VI "Fire Protection".

4.1.2 Automation systems, their elements and devices shall comply with the requirements of Section 2 and 3, Part XV "Automation".

4.2 GOVERNORS AND CONTROLS

4.2.1 The oil-fired boilers (main and auxiliary boilers for essential services) shall be equipped with automatic combustion controls. Oil-fired steam boilers shall be also equipped with feed water governors.

For other types of boilers these controls and governors are recommended.

4.2.2 Governors and controls shall be capable of maintaining the prescribed parameters within the predetermined limits over the entire steaming or heating (for thermal liquid boilers) load range.

4.3 PROTECTIVE DEVICES

4.3.1 All the boilers, except for the forced circulation boilers, the design of which allows operation with no water, and the headers of the secondary systems of the double-pressure boilers, shall be equipped with non-disconnectable protective devices for the lowest water level limit in the boiler (refer to 3.3.4).

4.3.2 Boilers with automatic burner units shall be protected according to the requirements of 5.3.

4.4 ALARMS

4.4.1 Boilers with automatic feed water governors and automatic burner units shall be equipped with visual and audible alarms at the local boilers control stations in accordance with 4.4.2 and 4.2.3.1 of Part VI "Fire Protection".

4.4.2 Visual and audible alarms shall function in case of:

- water level reaching its lowest limit;
- water level reaching its highest limit;
- failures in the automatic control systems and protective devices, in particular, at power failure;
- failure in the burner units (refer to 5.3.3);
- fire in the gas ducts of the boiler.

4.4.3 The lowest level limit alarms shall function prior to the operation of the protective devices.

4.4.4 Provision shall be made for manual disconnection of the audible alarm after its operation.

See Circular 1129c

5 OIL BURNER UNITS OF BOILERS

5.1 GENERAL

5.1.1 The general provisions concerning the technical supervision, technical documentation, manufacture and general requirements for oil burning installations are set forth in Section 1.

5.1.2 All the equipment to be used in oil burner units, such as pumps, fans, quick-closing valves, electric drives, shall be of a type approved by the Register and shall be manufactured under supervision of the Register or other competent authorities recognized by the Register.

Control, protective, interlocking and signalling devices shall comply with the requirements of Part XV "Automation".

5.1.3 The electrical equipment for oil burner units shall comply with the requirements of Part XI "Electrical Equipment".

5.1.4 Fuel oil used for boilers shall have a flash point in accordance with 1.1.2, Part VII "Machinery Installations".

5.1.5 Pipes and valves of oil burner units shall comply with the requirements of Part VIII "Systems and Piping".

5.1.6 Sight devices shall be provided for observation of the burning process.

5.1.7 Suitable devices shall be provided for extinguishing of manual igniters.

5.2 BURNERS

5.2.1 The burners shall be so designed as to ensure the possibility of controlling the size and shape of the flame jet.

5.2.2 In case of variable-delivery burners provision shall be made for controlling the combustion air supply.

5.2.3 It is recommended that the inlets of boiler fans be protected against penetration of moisture or solids.

5.2.4 Structural measures shall be provided to prevent the burners from being turned or removed from the working position before oil supply thereto has been stopped.

5.2.5 Where steam or air atomizing burners are used, structural measures shall be provided to prevent air or steam from penetration in the oil and vice versa.

5.2.6 Where boiler oil is heated, structural measures shall be taken to prevent oil overheating in heaters in case steam-generating capacity of the boiler is reduced or burners are shut-off.

5.2.7 Trays shall be provided in places where oil may leak.

5.3 AUTOMATIC BURNER UNITS

5.3.1 The requirements of the present Chapter apply to the burner units of continuously attended steam boilers and thermal liquid boilers.

5.3.2 Burner units shall be interlocked for fuel supply to the boiler furnace to be possible only under the following conditions:

- .1 the burner is in the operating position;
- .2 all the electrical equipment is connected to sources of electrical power;
- .3 pre-ventilation of the boiler furnace is completed;

.4 the pilot burner is alight or electrical ignition is switched on (when the main burner is being set alight);

.5 water level in the boiler is above the lowest limit (for steam boilers);

.6 the heat-transfer medium flow through the boiler is within the normal range (for forced-circulation steam boilers and thermal liquid boilers).

5.3.3 Burning installations shall be equipped with non-disconnectable protective devices to operate within 1 s maximum (for pilot burner — not more than 10 s) and to shut off automatically fuel supply to the burner in the cases of:

- .1 loss or low head of air flow to the furnace;
- .2 flame-jet cut-off at the burner;
- .3 water level in the boiler reaching its lowest limit;
- .4 heat-transfer medium flow going below the minimum allowable limit (for forced-circulation steam boilers and thermal liquid boilers).

5.3.4 Fuel supply shall be cut off by two self-closing series-connected valves or by a single valve if all the tanks, from which fuel is supplied, are arranged below the burning installation.

5.3.5 Burning installations shall be equipped with a burner flame-jet monitor. Such a monitor shall respond only to the flame jet of the burner under control.

5.3.6 The capacity of the pilot burner shall be such that the burner itself could not maintain the boiler under pressure with the steam consumption completely stopped (for thermal liquid boilers — at the working temperature of the thermal liquid in case where all consumers are cut off).

Where the pilot and main burners are simultaneously in operation and the protection devices are caused to function under conditions specified in 5.3.3, the pilot burner shall cease operation in the same time as the main burner.

5.3.7 Automatic burning installations of main and auxiliary boilers for essential services shall be capable of being manually controlled. Manual controls shall

be provided directly at the boiler. In this case, all interlocking devices required by 5.3.2 and protective devices specified in 5.3.3 shall function.

5.3.8 Provision shall be made for the burning installation to be shut off from two places, one of which shall be situated outside the boiler room.

6 HEAT EXCHANGERS AND PRESSURE VESSELS

6.1 GENERAL

6.1.1 The general provisions concerning the surveys, technical documentation, manufacture, materials and general requirements for pressure vessels and heat exchangers as well as strength calculation standards are set forth in Sections 1 and 2 (except 2.2.1.4).

6.1.2 The elements of heat exchangers and pressure vessels, which come in contact with sea water or other aggressive media, shall be manufactured from corrosion-resistant materials or provided with protection against corrosion.

6.1.3 The heat exchangers and pressure vessels shall preserve their serviceability under environmental conditions specified in 2.3, Part VII "Machinery Installations".

6.2 CONSTRUCTION REQUIREMENTS

6.2.1 The requirements of 3.2.1, 3.2.2, 3.2.4, 3.2.6, 3.2.7, 3.2.9, 3.2.10 and, where necessary, 3.2.13 also apply to pressure vessels and heat exchangers.

6.2.2 The construction shall provide, where necessary, for thermal elongation of the shells and various parts of heat exchangers and pressure vessels.

6.2.3 The shells of heat exchangers and pressure vessels shall be provided with suitable lugs for reliable attachment to the foundations. Overhead attachments shall be provided for, where necessary.

6.2.4 Additional requirements are given in 4.4, Part VII "Machinery Installations".

6.2.5 Manholes shall be provided to enable inspection of the internal surfaces of heat exchangers and pressure vessels. Where provision of manholes is not possible, hand holes shall be fitted in suitable places. Where the length of the heat exchanger or pressure vessel is over 2,5 m, hand holes shall be provided at both ends.

Manholes or hand holes are not required where the equipment is of dismantable construction or where corrosion and contamination of internal surfaces is completely eliminated.

Provision of manholes or hand holes is not necessary in heat exchangers and pressure vessels, which construction excludes the possibility of inspection through such holes.

For the dimensions of manhole openings, refer to 3.3.11.2.

6.3 VALVES AND GAUGES

6.3.1 Each heat exchanger, pressure vessel or their banks in permanent communication shall be fitted with non-disconnectable safety valves. Where there are several non-communicating spaces, safety valves shall be provided for each space.

Hydrophores shall be fitted with a safety valve to be installed on the water side.

In separate cases, on agreement with the Register, the variations from the above requirements may be permitted.

6.3.2 Safety valves shall generally be of a spring-loaded type. In fuel and oil heaters it is allowed to use safety diaphragms of a type approved by the Register and installed on the fuel and oil side.

6.3.3 The discharge capacity of safety valves shall be such that under no conditions the working pressure is exceeded by more than 15 per cent.

6.3.4 The safety valves shall be so designed as to allow of their being sealed or fitted with an equivalent safeguard to prevent valve adjustment without the knowledge of the operating personnel.

The materials used for springs and sealing surfaces of valves shall be capable of withstanding the corroding effect of the medium.

6.3.5 Level indicators and sight glasses may only be installed on heat exchangers and pressure vessels where the conditions of control and inspection so require. Level indicators and sight glasses shall be of a reliable design and shall have an adequate protection.

Flat glass plates shall be used for indicators of water, fuel oil or refrigerant level. Shut-off devices shall be installed between the level indicators and pressure vessels.

In deaerators cylindrical glasses may be used.

6.3.6 Heat exchangers and pressure vessels shall be provided with welded-on pads or short rigid connecting pieces for mounting valves. Use of threaded connections is permitted for hydrophores.

Fittings shall be mounted taking into consideration the requirements of 3.3.1.1.

6.3.7 Pressure vessels and heat exchangers shall be equipped with blow-down and drainage devices.

6.3.8 Each heat exchanger, pressure vessel or their groups in permanent connection shall be equipped with pressure gauges or compound gauges. Where heat exchangers have several spaces, pressure gauges shall be provided for each space.

Pressure gauges shall comply with the requirements set forth in 3.3.5.1, 3.3.5.5 and 3.3.5.7.

6.4 SPECIAL REQUIREMENTS FOR HEAT EXCHANGERS AND PRESSURE VESSELS

6.4.1 Air receivers.

6.4.1.1 When lifted, the safety valves on air receivers of main and auxiliary engines and of fire extinguishing systems shall fully stop the air bleeding in case of the pressure drop in the air receiver not below 85 per cent of the working pressure.

6.4.1.2 Where compressors, reduction valves or pipelines intended for air supply to air receivers are provided with safety valves, which are so installed that the air supply to air receivers under pressure exceeding the working pressure is excluded, the installation of safety valves on air receivers is not necessary. In this case, the air receivers shall be equipped with fusible plugs instead of safety valves.

6.4.1.3 The fusible plug shall have a fusion temperature from 100 °C to 130 °C. The fusion temperature shall be punched out on the fusible plug.

Air receivers having a capacity over 700 l shall be fitted with plugs not less than 10 mm in diameter.

6.4.1.4 Each air receiver shall be equipped with a device for moisture removal. In case of air receivers arranged horizontally, the moisture removal devices shall be provided at both ends of the receiver.

6.4.2 Condensers.

6.4.2.1 The construction of the condenser and its location on board the ship shall be such as to enable tube replacement.

The main condenser shell shall generally be steel welded.

Baffles shall be provided inside the condenser, at excess pressure steam inlets, to protect the tubes from direct steam impact.

The tube attachments shall be so designed as to prevent sagging and hazardous vibration of the tubes.

6.4.2.2 The covers of the condenser water chambers shall be fitted with manholes in number and position as may be required for ensuring access to the tubes in any part of the tube nest for the purpose of expansion, packing replacement, or plugging.

Cathodic protection shall be provided for the water chambers, tube plates and tubes for prevention of electrolytic corrosion.

6.4.2.3 The main condenser shall ensure the operation under damage conditions with any casing of the turbine set being disconnected.

6.4.2.4 The condenser shall be so designed as to enable the instrumentation specified in 19.4, Part VIII "Systems and Piping" to be connected to it.

6.4.3 Heat exchangers and pressure vessels of refrigerating plants and fire-fighting installations.

The heat exchangers and pressure vessels of refrigerating plants and fire-fighting installations

shall comply with the requirements of Section 5, Part XII "Refrigerating Plants" and Section 3, Part VI "Fire Protection", respectively.

6.4.4 Cylinders.

6.4.4.1 The present requirements apply to seamless cylinders with the capacity of not more than 200 l with the outside diameter not exceeding 420 mm and length not exceeding 2000 mm, which are filled with gas at special stations and are then delivered on board ships for storage and recovery of compressed and liquefied gases. Cylinders with welded ends shall be calculated for strength in compliance with Section 2 "Strength Calculations".

6.4.4.2 Where the outside diameter and wall thickness of a seamless cylinder are predetermined, the maximum permissible pressure p_D , in MPa, shall not exceed that determined by the following formula:

$$p_D \leq \frac{2\sigma(S - c)}{D_a - (S - c)} \quad (6.4.4.2)$$

where σ = permissible stress, MPa (refer to 2.1.4.6 with $n_T = 1,5$ and $n_B = 2,6$);

S = wall thickness, mm;

D_a = outside diameter, mm.

c = allowance for corrosion ($c = 1$ mm for air; $c = 0,3$ mm for liquefied gases; $c = 0$ for high strength steels, as well as without corrosive effect).

Where a cylinder is made of high strength steel with yield stress of not less than 750 MPa and with yield stress to tensile strength ratio of not less than 0,8, the ultimate strength safety factor n_B given in 6.4.4.2 may be assumed to be equal to 2,1.

In case the design pressure p for particular gas is above the maximum permissible p_D , it is allowed to reduce pressure p to the value $p < p_D$ at the expense of the reduction of the filling ratio of gas in the cylinder.

The design ambient temperature in the space for cylinder storage at the design pressure shall be kept below the critical value for the particular gas and shall be equal to:

50 °C — for ships of unrestricted service;

40 °C — for ships of restricted area of navigation in temperate zones;

45 °C — for liquefied carbon dioxide cylinders regardless of the area of navigation.

The design pressure and the filling ratio of carbon dioxide cylinders shall be chosen in compliance with the requirements of 3.8.2.1, Part VI "Fire Protection".

6.4.4.3 Ends geometry:

1 the dished spherical end at the transition from the cylindrical part of the cylinder shall have a thickness equal to the wall thickness of the cylindrical part. In way of the seamless cylinder manhole the thickness of the spherical end wall shall be increased by at least 1,5 times as compared to the cylindrical wall. In this case, the spherical part, being thickened, shall pass gradually into the cylinder manhole;

.2 the minimum thickness of the concave spherical end of the seamless cylinder shall be at least twice the thickness of the cylindrical part of the cylinder. The thickness of the lower cylindrical wall part of the cylinder shall gradually increase up to 1,7 the thickness of the cylinder wall in its cylindrical part. The depth of the concave end shall be not less than 0,12 the outside diameter of the cylinder.

6.4.4.4 After manufacture, each cylinder shall be subject to hydraulic tests in compliance with Table 1.7.1. In this case, the maximum design stresses shall not exceed 0,9 the yield stress of the cylinder material.

6.4.4.5 Where individual cylinder specimens are subject to hydraulic fracture tests, the safety factors may be reduced down as against those specified in 6.4.4.2.

6.4.4.6 Each cylinder and its valve head shall be fitted with a non-disconnectable safety device (breaking diaphragm, safety valve or fusible plug) preventing the cylinder from inadmissible temperature increase.

Safety valves and fusible plugs of the cylinders except for the liquefied carbon dioxide cylinders shall satisfy the requirements of 6.3.3, 6.4.1.1, 6.4.1.3. The opening pressure of breaking diaphragms shall be $1,1p$ where p is the design pressure.

Safety devices of liquefied carbon dioxide cylinders shall satisfy the requirements of 3.8.2.6.1, Part VI "Fire Protection".

6.4.4.7 For cylinders less than 100 l in capacity (except liquefied carbon dioxide cylinders) the safety devices may be omitted on agreement with

the Register provided the following requirements are met:

.1 cylinders shall not be located in the strength hull of the ship below the upper deck;

.2 temperature in spaces where the cylinders are installed shall not be above the value indicated in 6.4.4.2;

.3 spaces containing the cylinders shall be well removed from accommodation and service spaces and also from places and spaces where the equipment essential for safety of the ship is installed or flammable materials and fuel are stored.

6.4.4.8 Provision shall generally be made for enclosed gas outlet from the safety devices to the atmosphere.

In case of free air discharge from the safety valves of air receivers the requirements of 3.1.2.5, Part VI "Fire Protection" shall be observed.

Gas discharge from safety devices of cylinders of carbon dioxide smothering system shall be provided in accordance with 3.8.2.7, Part VI "Fire Protection".

6.4.4.9 For cylinders filled without the use of the shipboard equipment (ship's compressors, etc.) installation of pressure gauges is not obligatory. However, in any case the pressure control in any cylinder shall be possible.

6.4.4.10 The cylinders shall be equipped with blow-down and drainage devices, if required.

6.4.4.11 Spaces for storage of the cylinder containing explosive gases shall have an access from the weather deck.

7 STRENGTH CHARACTERISTICS OF BOILER STEEL

7.1 LOWER YIELD STRESS AS A FUNCTION OF DESIGN TEMPERATURE, MPa

Table 7.1

Kind of steel	R_m MPa	Design temperature, °C							
		20	100	200	250	300	350	400	450
Carbon steel Cr.10	330	195	186	177	162	147	127	108	78
Carbon steels 12K & 15K	350	205	196	181	167	142	118	98	78
Carbon steel Cr.3	370	205	196	186	177	157	—	—	—
Carbon steels 16K, 20 & 20K	400	235	226	206	186	157	137	118	98
Carbon steel 18K	430	255	245	226	206	177	157	137	118
Alloy steel 15XM	440	225	226	221	216	216	206	196	191
Alloy steel 12X1MΦ	440	255	255	250	245	235	226	216	206
Alloy steels 16ГC & 09Г2C	450	265	255	235	226	196	177	157	123
High-manganese steel 22ГK	530	335	324	304	284	275	255	245	235

7.2 AVERAGE STRESS TO PRODUCE RUPTURE IN 100 000 HOURS AS A FUNCTION OF DESIGN TEMPERATURE, MPa

Table 7.2

Kind of steel	R_m	R_{eH}	Design temperature, °C							
			MPa		370	380	390	400	410	420
Carbon steels 10, 12K and 15K	330 — 350	195 — 205	186	157	137	118	103	88	74	64
Carbon steels 16K, 18K, 20 and 20K	400 — 430	235 — 255	216	186	162	142	127	108	98	83
Alloy steel 15XM	440	225	—	—	—	—	—	—	—	—
Alloy steel 12X1MΦ	440	255	—	—	—	—	—	—	—	—
Alloy steels 16ГC and 09Г2C	450	265	255	216	186	167	147	127	113	98
High-manganese steel 22ГK	530	335	245	226	206	186	167	157	137	118

Table 7.2 — continued

Kind of steel	R_m	R_{eH}	Design temperature, °C									
			MPa		450	460	470	480	490	500	510	520
Carbon steels 10, 12K and 15K	330 — 350	195 — 205	59	—	—	—	—	—	—	—	—	—
Carbon steels 16K, 18K, 20 and 20K	400 — 430	235 — 255	69	—	—	—	—	—	—	—	—	—
Alloy steel 15XM	440	225	265	245	226	196	157	137	118	103	88	
Alloy steel 12X1MΦ	440	255	—	—	—	196	186	177	167	152	137	
Alloy steels 16ГC and 09Г2C	450	265	88	78	69	—	—	—	—	—	—	
High-manganese steel 22ГK	530	335	103	93	83	74	69	59	49	34	25	

APPENDIX

TYPICAL EXAMPLES OF ALLOWABLE WELDED JOINTS FOR BOILERS,
HEAT EXCHANGERS AND PRESSURE VESSELS

Dimensions of structural elements of the prepared edges of welded parts and dimensions of welds shall be taken according to national standards, having regard to the welding method used.

The typical examples of allowable welded joints are given in the present Appendix. Different types of welded joints shall not be considered as equivalents, and the order in which they are presented is not indicative of their strength characteristics. The types of welded joints shown for the elements shall be used

on condition that adequate strength of the structure is ensured.

Depending on the characteristics of the materials used and also on further improvement of the welding procedure, other types of welded joints may also be allowed. In this case and also in case the typical examples of the welded joints cannot be used in whole, the type of the welded joint shall be agreed with the Register.

ALLOWABLE WELDED JOINTS

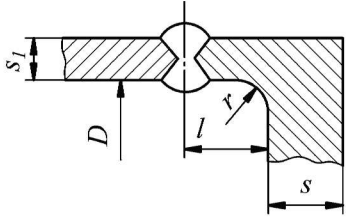
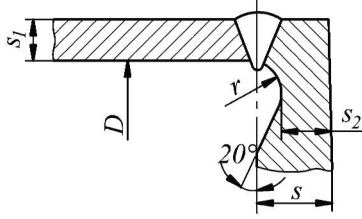
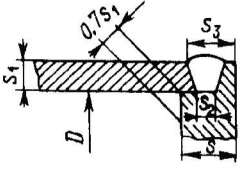
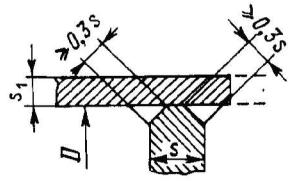
1 Flat end plates and covers	
1.1	 <div style="margin-left: 200px;"> $k = 0,38,$ $r \geq s/3,$ but not less than 8 mm, $l \geq s$ </div>
1.2	 <div style="margin-left: 200px;"> $k = 0,45,$ $r \geq 0,2s,$ but not less than 5 mm, $s_2 \geq 5$ mm Refer to Note 1 </div>
1.3	 <div style="margin-left: 200px;"> $k = 0,5,$ $s_2 \leq s_1,$ but not less than 6,5 mm, $s_3 \geq 1,25s_1$ Refer to Note 1 </div>
1.4	 <div style="margin-left: 200px;"> $k = 0,45$ Refer to Note 1 </div>

<p>1.5</p>		<p>$k=0,55$ Refer to Note 1</p>
<p>1.6</p>		<p>$k=0,57$</p>
<p>2 Dished ends</p>		
<p>2.1</p>		<p>It is permitted for boilers and pressure vessels of Classes I, II and III Refer to Notes 2, 17</p>
<p>2.2</p>		<p>It is permitted for boilers and pressure vessels of Classes II and III</p>
<p>2.3</p>		<p>This joint shall be avoided. It is permitted only for pressure vessels of Class III where no danger of corrosion exists $s_1 \leq 16$ mm, $D \leq 600$ mm</p>
<p>2.4</p>		<p>It is permitted only for pressure vessels of Class III $s_1 \leq 16$ mm, $D \leq 600$ mm</p>

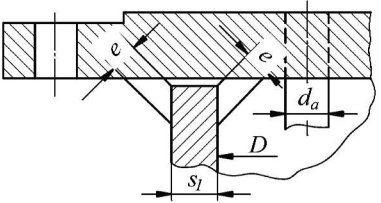
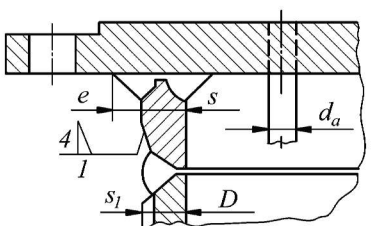
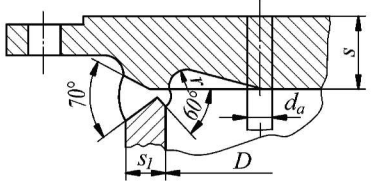
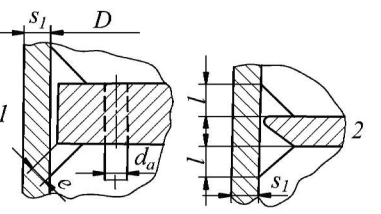
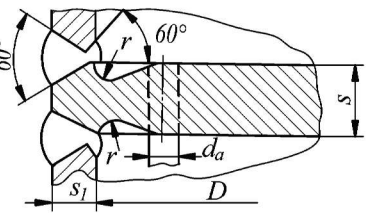
3 Tube plates		
3.1		<p> $k=0,45,$ $e=0,71s_l,$ $s_l \leq 16 \text{ mm}$ Refer to Notes 3, 4 </p>
3.2		<p> $k=0,45,$ $e=s_l/3,$ but not less than 6 mm, $s_l > 16 \text{ mm}$ Refer to Notes 5, 6 </p>
3.3		<p> $k=0,45,$ $r \geq 0,2s,$ but not less than 5 mm </p>
3.4		<p> $k=0,45$ Type 1: $e \geq 0,71s_l,$ but at $e > 13 \text{ mm}$ Type 2 is preferable, where $l=s_l/3,$ but not less than 6 mm Refer to Note 7 </p>
3.5		<p> $k=0,45,$ $r \geq 0,2s,$ but not less than 5 mm </p>

4 Tubes		
4.1		$e = s_r$ $e \geq 5 \text{ mm}$ $s_r \geq 2,5 \text{ mm}$ Refer to Notes 8, 9, 10
4.2		$d = s_r; l_1 = s_r; 1,5s_r < l < 2s_r$ Type 1: $s_r \geq 5 \text{ mm}; l = s_r$ Type 2: $s_r < 5 \text{ mm}$ Refer to Note 11
4.3		$e = 0,7s_r$ $s_r \geq 3 \text{ mm}$ Refer to Note 12
5 Long and short stays, stay tubes		
5.1		$k = 0,42$
5.2		$k = 0,34$
5.3		$k = 0,38$ Short stays (Refer to 3.2.2)

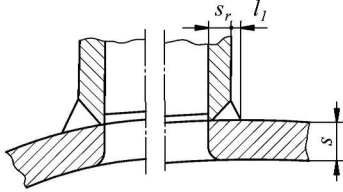
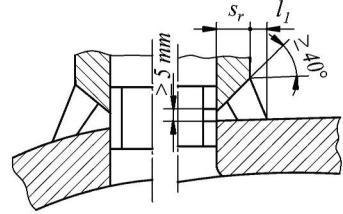
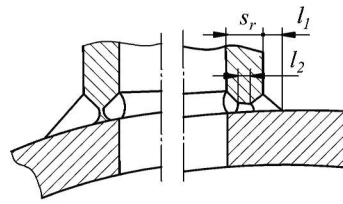
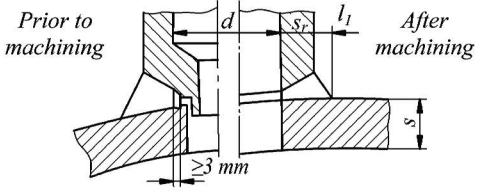
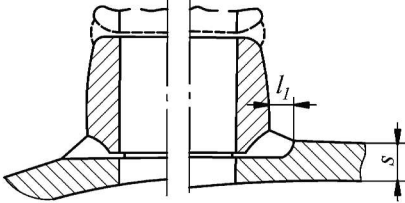
6 Branches, nozzles, pads		
6.1 Welded-on branches, non-through		
6.1.1		$s_r \leq 16 \text{ mm},$ $l_1 = s_r/3, \text{ but not less than } 6 \text{ mm}$
6.1.2		$l_1 \geq s_r/3, \text{ but not less than } 6 \text{ mm}$ Refer to Note 13
6.1.3		$l_2 = 1,5 \dots 2,5 \text{ mm}$ $l_1 \geq s_r/3, \text{ but not less than } 6 \text{ mm}$ Refer to Note 14
6.1.4		$l_1 \geq s_r/3, \text{ but not less than } 6 \text{ mm}$ Refer to Notes 15, 16
6.1.5		$l_1 = 10 \dots 13 \text{ mm}$ Refer to Note 15

6.2 Welded-on branches, through		
6.2.1		<p>The joint is mainly used at $s_r < s/2$, $e = s_r$</p>
6.2.2		<p>The joint is mainly used at $s_r = s/2$, $e = 6 \dots 13 \text{ mm}$, $e + l = s_r$</p>
6.2.3		<p>The joint is mainly used at $s_r > s/2$, $e \geq s/10$, but not less than 6 mm</p>
6.3 Upset nozzles		
6.3.1		
6.3.2		<p>Refer to Note 17</p>

6.4 Branches with disc-shaped reinforcing plates		
6.4.1		$l \geq s_r/3$, but not less than 6 mm
6.4.2		$l \geq s_r/3$, but not less than 6 mm, $l_1 \geq 10$ mm
6.4.3		$e + l = s_r$ or $e + l = s_{bf}$, whichever is the less, $l_1 \geq 10$ mm
6.4.4		$e_2 + l \geq s_r$, $l_1 \geq 10$ mm, $2s_r \leq (e_2 + l) + \text{the lesser of the values } (s_{bf} + e_1) \text{ or } l_1$
6.5 Pads and nozzles for studs		
6.5.1		$d_2 \leq d_1 + 2s_{min}$ Refer to Note 18
6.5.2		$s \leq 10$ mm Refer to Notes 19, 20

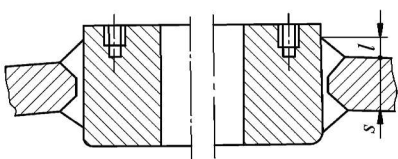
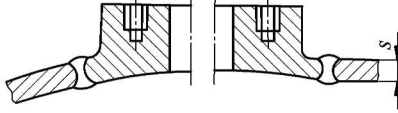
<p>6.5.3</p>		<p>$l \geq 6 \text{ mm},$ $s \leq 20 \text{ mm}$</p>
<p>6.5.4</p>		<p>$s \geq 20 \text{ mm}$</p>

6.6 Pads and nozzles for threaded joints

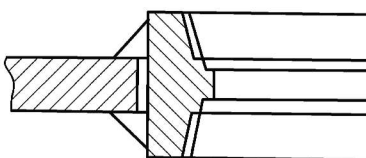
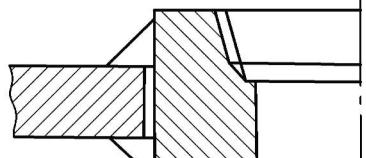
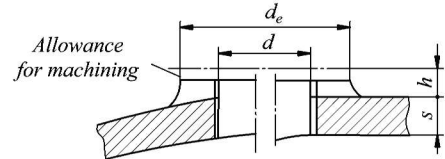
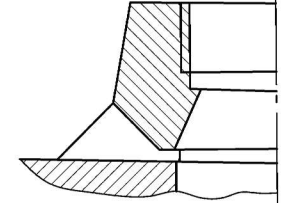
<p>6.6.1</p>		
<p>6.6.2</p>		
<p>6.6.3</p>		<p>$d \leq s,$ $d_e = 2d,$ $h \leq 10 \text{ mm},$ $h \leq 0,5s$ Refer to Note 21</p>
<p>6.6.4</p>		

Appendix — continued

- Notes: 1. The welded joints are applicable to boilers having a shell diameter up to 610 mm. For pressure vessels they may be used without restrictions in case $R_m \leq 460$ MPa or $R_{eH} \leq 365$ MPa.
2. Reduction in thickness of the shell or flange part of the end may be effected either on the inside or on the outside.
 3. This type of the welded joint is used when both sides of the shell are accessible for welding.
 4. For shells over 16 mm in thickness the fillet welds are effected with the edge preparation of the shell according to Fig. 3.2.
 5. This type of the welded joint is used when the shell is accessible for welding only on the outside.
 6. For shells less than 16 mm in thickness the fillet welds may be effected without the edge preparation of the shell. The height of the ring shall not be less than 40 mm.
 7. Clearance between inside diameter of the shell and the outside diameter of the tube plate shall be minimized as far as possible.
 8. The end of the tube protruding outside the weld seam is removed by milling or grinding.
 9. The distance between tubes shall not be less than $2,5s_r$, but never below 8 mm.
 10. In case of the manual electric arc welding it is necessary that the thickness shall be $s_r \geq 2,5$ mm.
 11. It is recommended when the tube plate deformations resulting from welding shall be minimized.
 12. Attachment of tubes is effected by manual electric arc welding.
 13. The backing ring shall be tightly fitted and removed after welding.
 14. It is used when welding is possible on the inside of the branch.
 15. It is used for branches of small sizes as compared to those of pressure vessels.
 16. After welding the branch is machined to the final size d .
 17. The dimensions of cylindrical portions l shall be such that the radiographic testing could be carried out, if necessary.
 18. The clearance between the pads and the pressure vessel shall not exceed 3 mm.
 19. The clearance between the opening and the outside nozzle diameter shall be minimal and in no case shall it exceed 3 mm.
 20. The upper holes for studs shall be displaced in relation to the lower ones.
 21. The total thickness of the pressure vessel shell and the weld metal shall be sufficient for provision of the required number of threads.

LIST OF CIRCULAR LETTERS AMENDING/SUPPLEMENTING NORMATIVE DOCUMENT

(Normative document No. and title)

Item No.	Circular Letter No., date of approval	List of amended and introduced paras/chapters/sections



RUSSIAN MARITIME REGISTER OF SHIPPING

CIRCULAR LETTER

No. 313-10-1129c

dated 18.05.2018

Re:

amendments to the Rules for the Classification and Construction of Sea-Going Ships, 2018, ND No. 2-020101-104-E, in connection with entering into force of IACS Unified Interpretation (UI) SC 283 (Aug 2017)

Item(s) of supervision:

ships under construction

Implementation:

from the date of publication

Valid till:

Validity period extended till:

Cancels / amends / adds Circular Letter No.

-

dated -

Number of pages:

1

Appendix(-ces):

text of amendments to Part X "Boilers, Heat Exchangers and Pressure Vessels"

Acting Director General

S.A. Kulikov

Text of CL:

We hereby inform that in connection with entering into force of IACS UI SC 283 (Aug 2017), Part X "Boilers, Heat Exchangers and Pressure Vessels" shall be amended to read: New para 4.4.5 shall be introduced reading as follows: "For boilers with inherent fire risk in the air supply casing and supply ducts and in the flue gas channels and uptake, means to detect and give alarms at an early stage of fire shall be provided. Boilers with inherent fire risk in the air supply casing and supply ducts means boilers equipped with rotary heat exchangers having surfaces exposed alternately to air and flue gas. Boilers with inherent fire risk in the flue gas uptake and ducts means boilers equipped with heat exchangers using flue gases as the heating medium (e.g. air/water preheaters or economizers, etc.).". The original of IACS UI SC 283 (Aug 2017) in English is posted on the RS internal website in the Section "RS External Normative Documents"/02 IACS Documents/ND No.1-0221-283-E", as well as on the official IACS website: www.iacs.org.uk.

It is necessary to do the following:

1. Apply provisions of the Circular Letter during the review and approval of technical documentation for ships contracted for construction on or after 1 July 2018.
2. Bring the content of the Circular Letter to the notice of the RS surveyors, interested organizations and persons in the area of the RS Branch Offices' activity.

List of ND amended and introduced paras/chapters/sections (to specify in the List of Circular Letters (form 8.3.36)):

Chapter 4.4: para 4.4.5

Person in charge:

Vladimir K. Shurpyak

313

+7 (812) 312-39-85

"Thesis" System No.

18-120688



RUSSIAN MARITIME REGISTER OF SHIPPING

CIRCULAR LETTER

No. 313-08-1163c

dated 24.09.2018

Re:

amendments to the Rules for the Classification and Construction of Sea-Going Ships, 2018, ND No. 2-020101-104-E

Item(s) of supervision:

ships under construction

Implementation:
from the date of publication

Valid till:

Validity period extended till: ----

Cancels / amends / adds Circular Letter No. ----

dated -----

Number of pages: 1 + 4

Appendix(ces):

amendments to Parts VI "Fire Protection", VII "Machinery Installations", IX "Machinery", X "Boilers, Heat Exchanges and Pressure Vessels" and XVII "Distinguishing Marks and Descriptive Notations in the Class Notation Specifying Structural and Operational Particulars of Ships" of the Rules for the Classification and Construction of Sea-Going Ships

Director General

Konstantin G. Palnikov

We hereby inform that Parts VI "Fire Protection", VII "Machinery Installations", IX "Machinery", X "Boilers, Heat Exchanges and Pressure Vessels" and XVII "Distinguishing Marks and Descriptive Notations in the Class Notation Specifying Structural and Operational Particulars of Ships" of the Rules for the Classification and Construction of Sea-Going Ships for the Classification and Construction of Sea-Going Ships, 2018, ND No. 2-020101-104-E, shall be amended as specified in the Appendix to the Circular Letter.

Insert text here

It is necessary to do the following:

1. Apply provisions of the Circular Letter during review and approval of technical documentation on ships.
 2. Bring the content of the Circular Letter to the notice of the RS surveyors and interested organizations in the area of the RS Branch Offices' activity.
-

List of ND amended and introduced paras/chapters/sections (to specify in the List of Circular Letters (form 8.3.36)):

Part VI: Table 3.1.2.1, paras 3.2.3.6, 3.12.1;

Part VII: paras 2.1.8, 3.3.1, 4.5.11, 4.5.13.3;

Part IX: paras 9.1.1, 9.5.1;

Part X: Chapter 1.8, para 1.8.2;

Part XVII: paras 3.5.2.2.4, 3.5.3.3.2, 3.5.3.3.3, 3.5.3.3.4, 3.5.3.3.8, 3.6.2.2.1, 3.6.3.3.2, 3.6.3.3.3, 3.6.3.3.8, 3.6.3.6.4

Person in charge: Ekaterina A. Shvedova 313

(812) 312-39-85

"Thesis" System No. 18-251114

**RULES FOR THE CLASSIFICATION AND CONSTRUCTION OF SEA-GOING SHIPS,
2018, ND No. 2-020101-104-E**

PART VI. FIRE PROTECTION

Table 3.1.2.1. Footnote 15 shall be supplemented by the following text:

"This requirement does not apply to fishing vessels of less than 500 gross tonnage."

Para 3.2.3.6 shall be amended in the Russian version only.

Para 3.12.1 shall be supplemented by the following text:

"The provisions of this Chapter do not apply to fishing vessels."

PART VII. MACHINERY INSTALLATIONS

Para 2.1.8 shall be supplemented by a new paragraph reading as follows:

"Another speed may be set for the ships intended for navigation in geographically restricted areas while providing sufficient speed to maintain the ship's handling capability in load condition."

Para 3.3.1 shall be amended in the Russian version only.

Para 4.5.11 shall be amended to read:

"**4.5.11** In fishing vessels of more than 1000 gross tonnage one means of escape from machinery spaces of category A may be provided on the condition that it leads directly onto the open deck, the spaces are entered only periodically and the maximum travel distance to the door (hatch) leading directly onto open deck from the control stations of the equipment located in the space is 5 m or less. In cargo ships of less than 1000 gross tonnage, the Register may dispense with one of the means of escape from machinery spaces of category A, due regard being paid to the dimension and disposition of the upper part of the space. In addition, the means of escape in these ships need not comply with the requirements for an enclosure listed in paragraph 4.5.10.1."

Para 4.5.13.3 shall be amended to read:

".3 escape routes that pass only through stairways and/or corridors are considered as providing "direct access to the open deck" if outside the steering gear spaces they have continuous fire shelter equivalent to steering gear spaces or stairways and corridors, whichever is greater."

PART IX. MACHINERY

Para 9.1.1 shall be supplemented by the following text:

"The requirements of 9.2.2, 9.2.3 are applicable to engines operating on gas with a maximum working gas pressure of more than 1,0 MPa."

Para 9.5.1 shall be supplemented by the following text:

"For engines operating on gas with a maximum working gas pressure of not more than 1,0 MPa, the use of other design solutions is allowed provided that proving calculations or experimental data are provided."

PART X. BOILERS, HEAT EXCHANGERS AND PRESSURE VESSELS

Chapter 1.8 shall be renamed reading as follows:

"1.8 BOILER ROOMS".

Para 1.8.2 shall be deleted.

PART XVII. DISTINGUISHING MARKD AND DESCRIPTIVE NOTATIONS IN THE CLASS NOTATION SPECIFYING STRUCTURAL AND OPERATIONAL PARTICULARS OF SHIPS

Para 3.5.2.2.4 shall be amended to read:

3.5.2.2.4 Where NO_x-reducing device is used, it shall be considered as the engine component. When for NO_x reduction a selective catalytic reduction (SCR) system is used, the requirements of IMO resolution MEPC.291(71) shall be complied with."

Para 3.5.3.3.2 shall be amended to read:

3.5.3.3.2 To keep cargo spills within the cargo area, provision shall be made for a permanent continuous coaming on the cargo deck extending from side to side and from a point 0,2L forward of amidships to the aft end of the cargo deck with height dimensions given in Table 3.5.3.3.2."

Table 3.5.3.3.2. The column heading "Minimum heights of continuous coaming" shall be replaced by:

"Height dimensions of continuous coamings";

in the last column the values of aft ends of cargo deck for ships of 100000 t deadweight and above shall be replaced by "0,30 m".

Para 3.5.3.3.3 shall be amended to read:

"3.5.3.3.3 To collect possible oil spills during cargo operations the main deck in the cargo area shall be fitted with a system for collection of the spilled cargo with its accumulation in a holding tank or a slop tank.

Collection of the spilled cargo may be performed using particular pump and pipes located in the cargo area or by gravity drainage through specially provided pipes. The system shall be provided with means for removal of cargo residues from the pipes, when the collection of the spilled cargo is over.

Automatic gravity drainage shall be used during cargo operations where cargo spills may occur, and shall not be used under normal conditions when at sea. For gravity drainage, each pipe of deck system shall be arranged with a manually operated valve opened only during cargo operations and an automatic scupper."

Para 3.5.3.3.4 shall be amended to read:

"3.5.3.3.4 On oil tankers, chemical tankers and NLS tankers, the points where cargo hoses are connected to cargo manifolds shall be fitted with pipes for drainage of leaks to a holding tank or a slop tank.

The trays shall have the following minimum dimension:

tray length shall be so that the cargo manifold doesn't extend beyond forward and aft ends of the tray;

width — at least 1,8 m, at that the spill tray extends at least 1,2 m outboard of the end of the manifold flange;

minimum depth — 0,3 m".

Para 3.5.3.3.8. In the first paragraph the word "pipes" shall be replaced by the word "manifolds";

the second paragraph shall be introduced reading as follows:

"These requirements shall not be applied to locations of receiving fuel and lubricating oil manifolds provided on general location area together with cargo manifolds, the locations of which shall be fitted with trays according to 3.5.3.3.4."

Para 3.6.2.2.1 shall be amended to read:

"Compliance with the requirements shall be confirmed in accordance with 3.5.2.2.1 — 3.5.2.2.5 and 3.5.2.2.9 — 3.5.2.2.10."

Paras 3.6.2.2.1 — 3.6.2.2.4 shall be deleted.

Para 3.6.3.3.2. The words "deck scupper" shall be deleted.

Para 3.6.3.3.3 shall be amended to read:

"3.6.3.3.3 On oil tankers, chemical tankers and NLS tankers where cargo hoses are connected to cargo manifolds, the provision shall be made for spill trays with dimensions and pipes according to 3.5.3.3.4."

Para 3.6.3.3.8 shall be amended to read:

"In addition to the requirements specified in 3.5.3.3.8, locations on the open deck in the areas of receiving fuel and lubricating oil manifolds shall be fitted with a system for collection of the spilled cargo with its accumulation in a holding tank or a slop tank.

Collection of the spilled cargo may be performed using particular pump and pipes located in the areas of receiving fuel and lubricating oil manifolds or by gravity drainage through specially provided pipes. Automatic gravity drainage shall be used during bunkering operation where fuel and oil spills may occur. For gravity drainage, each pipe of deck system shall be arranged with a manually operated valve opened only during bunkering operation and an automatic scupper."

Para 3.6.3.6.4. The second sentence shall be amended to read:

"When the ship is operated in special areas defined in compliance with the amendments to Annex IV to MARPOL 73/78 in IMO resolution MEPC.200(62), the above plant shall have a Certificate of type approval for sewage treatment plants in compliance with IMO resolution MEPC.227(64), including provisions specified in 4.2 of the resolution."

Российский морской регистр судоходства
Правила классификации и постройки морских судов
Часть X
Котлы, теплообменные аппараты и сосуды под давлением

Russian Maritime Register of Shipping
Rules for the Classification and Construction of Sea-Going Ships
Part X
Boilers, Heat Exchangers and Pressure Vessels

The edition is prepared
by Russian Maritime Register of Shipping
8, Dvortsovaya Naberezhnaya,
191186, St. Petersburg,
Russian Federation
www.rs-class.org/en/