

RUSSIAN MARITIME REGISTER OF SHIPPING

RULES
FOR THE CLASSIFICATION
AND CONSTRUCTION
OF SEA-GOING SHIPS

PART XI
ELECTRICAL EQUIPMENT



Saint-Petersburg
Edition 2018

Rules for the Classification and Construction of Sea-Going Ships of Russian Maritime Register of Shipping have been approved in accordance with the established approval procedure and come into force on 1 January 2018.

The present edition of the Rules is based on the 2017 edition taking into account the amendments developed immediately before publication.

The unified requirements, interpretations and recommendations of the International Association of Classification Societies (IACS) and the relevant resolutions of the International Maritime Organization (IMO) have been taken into consideration.

The Rules are published in the following parts:

Part I "Classification";

Part II "Hull";

Part III "Equipment, Arrangements and Outfit";

Part IV "Stability";

Part V "Subdivision";

Part VI "Fire Protection";

Part VII "Machinery Installations";

Part VIII "Systems and Piping";

Part IX "Machinery";

Part X "Boilers, Heat Exchangers and Pressure Vessels";

Part XI "Electrical Equipment";

Part XII "Refrigerating Plants";

Part XIII "Materials";

Part XIV "Welding";

Part XV "Automation";

Part XVI "Hull Structure and Strength of Glass-Reinforced Plastic Ships and Boats";

Part XVII "Distinguishing Marks and Descriptive Notations in the Class Notation Specifying Structural and Operational Particulars of Ships";

Part XVIII "Common Structural Rules for Bulk Carriers and Oil Tankers". The text of the Part is identical to that of the IACS Common Structural Rules;

Part XIX "Additional Requirements for Structures of Container Ships and Ships, Dedicated Primarily to Carry their Load in Containers". The text of the Part is identical to IACS UR S11A "Longitudinal Strength Standard for Container Ships" (June 2015) and S34 "Functional Requirements on Load Cases for Strength Assessment of Container Ships by Finite Element Analysis" (May 2015).

Parts I to XVII are published in electronic format and hard copy in Russian and English. In case of discrepancies between the Russian and English versions, the Russian version shall prevail.

Parts XVIII to XIX are published in English and in electronic format only.

As compared to the previous 2017 edition, the present edition contains the following amendments.

RULES FOR THE CLASSIFICATION AND CONSTRUCTION OF SEA-GOING SHIPS

PART XI. ELECTRICAL EQUIPMENT

1. Paras 2.1.3.2, 2.3.2.2, 2.4.3.1, 2.9.10, 3.1.4, 3.2.3.2, 3.2.4.1, 4.1.1, 4.6.4.8, 4.6.4.11, 7.5.13.5, 8.3.2, 9.1.1, 9.4.2, 10.5.3, 11.1.2, 12.1.1, 12.1.3, 12.2.1, 13.3.1, 15.4.2, 16.3.1, 16.4.1, 17.3.2, 18.6.2.4, 19.2.6.1, 19.4.4.2, 19.5.2.1, 19.8.2.2, 19.9.6, 19.10.2: the requirements have been specified to avoid ambiguous phrases "special consideration by the Register", "special approval by the Register" and "special agreement by the Register".

2. Para 18.5.1.3 has been deleted to avoid ambiguous phrase "special consideration by the Register".

3. Chapter 2.3: para 2.3.1.3 has been supplemented with the new para making allowance for using aluminium in the windings of high voltage transformers.

4. Chapter 2.5: para 2.5.3.2 has been supplemented with the standards of earthing resistance.

5. Chapter 4.6: the requirements of para 4.6.1.7 have been specified making allowance for supplying the lighting fixtures of generator panels from the emergency switchboard;

the requirements of para 4.6.1.9 have been supplemented with the switchboards not accessible from the rear.

6. Chapter 5.8: the requirements of para 5.8.4 have been supplemented making allowance for manual switching off of the fan motors in spaces protected by a smothering system.

7. Chapter 6.2: the requirement of para 6.2.3 has been supplemented making allowance for the supply feeders for lighting of corridors, machinery spaces, propeller shaft tunnels, boiler water-level indicators;

para 6.2.6: the requirements have been specified.

8. Chapter 7.4: para 7.4.1 has been specified to exclude the requirements for emergency alarm from Part XI; para 7.4.8 has been amended in compliance with 6.22.1.1, Part II "Life-Saving Appliances" of the Rules for the Equipment of Sea-Going Ships to exclude the requirement for the self-return switch of the general alarm system.

9. Chapter 9.2: para 9.2.1 has been amended in compliance with Reg. II-1/43.1.2 SOLAS-74.

10. Chapter 9.3: a reference to another Part of the Rules has been specified in para 9.3.1.7.

11. Chapter 16.8: para 16.8.7.3 has been deleted.

12. Chapter 17.3: para 17.3.4 has been specified.

13. Chapter 17.7: the requirements of para 17.7.2.4 regarding the protection of bearings from flowing currents have been amended in compliance with 10.3.4.

14. Chapter 18.4: has been supplemented with a new para 18.4.1.6 with requirements allowing for the use of aluminium in windings of high-voltage transformers.

15. Chapter 19.1: a reference to another Part of the Rules has been specified in para 19.1.2.1.7.

16. Chapter 19.4: a reference to another Part of the Rules has been specified in para 19.4.3.1.

17. Chapter 19.8: has been supplemented with a new para 19.8.14.4 considering the location of the emergency diesel generator.

18. A new Section 22 "Special requirements to electrical equipment of the ship's electric power system with electrical power distribution for direct current" on the basis of Scientific Research 21/2015-2016 has been introduced.

19. Editorial amendments have been made.

CONTENTS

PART XI. ELECTRICAL EQUIPMENT

1	General	7	5.10	Electric drives of watertight and fire doors	34
1.1	Application	7	5.11	Electric drives for oil burner units of boilers and incinerators	35
1.2	Definitions and explanations	7	5.12	Electric drives of dewatering arrangements of forward spaces of bulk carriers	35
1.3	Scope of surveys	8	6	Lighting	36
1.4	Technical documentation	9	6.1	General	36
2	General requirements	11	6.2	Power supply of main lighting electric circuits	36
2.1	Operating conditions	11	6.3	Emergency lighting	37
2.2	Electromagnetic compatibility	12	6.4	Switches in lighting circuits	37
2.3	Materials	14	6.5	Gas discharge lamp installations	37
2.4	Structural requirements and protection of electrical equipment	14	6.6	Socket outlets	37
2.5	Protective earthing of metal parts, which do not carry current	15	6.7	Illumination	38
2.6	Lightning protection	17	6.8	Navigation lights	38
2.7	Arrangement of electrical equipment	18	6.9	Lighting and illumination means of helidecks	39
2.8	Special electrical spaces	18	7	Internal communication and signalling	40
2.9	Safe-type electrical equipment	19	7.1	Electric engine room telegraphs	40
2.10	Antistatic earthing	20	7.2	Internal service communication	40
2.11	Arrangements and systems for insulation resistance monitoring	21	7.3	Signalling. General	41
3	Main electrical power source	22	7.4	General alarm system	41
3.1	Composition and capacity of main electrical power source	22	7.5	Fire detection and fire alarm system	42
3.2	Generator sets	22	7.6	Release indication of fire smothering system	45
3.3	Number and capacity of transformers	23	7.7	Indication of closing watertight and fire doors	45
3.4	Power supply from an external source of electrical power	23	7.8	Sound signals in engineers' accommodation spaces	45
3.5	Connection of electrical power supply units	24	7.9	Personnel alarm	46
4	Distribution of electrical power	25	7.10	Cargo hold water level alarm system on bulk carriers, passenger ships carrying 36 persons and more and single-hold cargo ships other than bulk carriers	46
4.1	Distribution systems	25	7.11	Alarm of ultimate concentration of dangerously explosive and noxious gases	46
4.2	Permissible voltage	25	7.12	Indication of door position in ro-ro passenger ships and ro-ro cargo ships	47
4.3	Power supply of essential services	25	7.13	Release indication of fixed local application fire extinguishing system	48
4.4	Power supply of electrical (electronic) automation systems	26	7.14	Television surveillance and indication system	48
4.5	Power supply to integrated bridge control console	26	7.15	Sewage holding tanks level alarm	49
4.6	Switchboard and switchgear	27	7.16	Bulkhead shaft-gland, bearing and pump case temperature excess alarm	49
5	Electric drives for shipboard mechanisms and equipment	31	7.17	Maximum permissible cargo temperature excess alarm	49
5.1	General	31	7.18	Overpressure or underpressure in the cargo tanks alarm system	49
5.2	Interlocking of machinery operation	31	7.19	High- and limit-level alarms in cargo tanks	49
5.3	Safety isolation devices	31			
5.4	Switchgear and control gear	31			
5.5	Electric drives and control of steering gear	32			
5.6	Electric drives of anchor and mooring machinery	33			
5.7	Electric drives of pumps	33			
5.8	Electric drives of fans	34			
5.9	Electric drives of boat winches	34			

8	Protective devices.	50	14	Electrical apparatus and accessories	66
8.1	General	50	14.1	Electrical apparatus	66
8.2	Protection of generators	50	14.2	Electrical accessories	67
8.3	Protection of electric motors	51	15	Electrical cooking and heating appliances.	69
8.4	Steering gear protection	52	15.1	General	69
8.5	Protection of transformers	52	15.2	Heating appliances	69
8.6	Protection of accumulator batteries	52	15.3	Oil, fuel and water heaters	69
8.7	Protection of pilot lamps, voltmeters, capacitors and voltage coils	52	15.4	Systems utilising heating cables	70
8.8	Protection of power semiconductor units	53	16	Cables and wires.	71
8.9	Residual-current devices (RCD)	53	16.1	General	71
9	Emergency electrical installations.	54	16.2	Cable conductors	71
9.1	General	54	16.3	Insulating materials	71
9.2	Spaces of emergency sources of electrical power	54	16.4	Cable sheathing	71
9.3	Emergency sources of electrical power in cargo ships	55	16.5	Protective coverings	72
9.4	Distribution of electrical power from emergency sources	56	16.6	Marking	72
9.5	Starting arrangements for emergency diesel generators	56	16.7	Hookup wires	72
9.6	Alarm system and protection of emergency diesel generator drives	57	16.8	Cabling	72
9.7	Uninterruptible power system (UPS)	57	17	Electric propulsion plants	80
10	Electrical machines.	58	17.1	General	80
10.1	General	58	17.2	Definitions and explanations	80
10.2	Slip rings, commutators and brushes	58	17.3	Configuration of electric propulsion plants	81
10.3	Bearings	58	17.4	Excitation systems	81
10.4	Temperature detectors	59	17.5	Electromagnetic compatibility (EMC)	82
10.5	Overcurrent	59	17.6	Prime movers of electric propulsion plant generators	82
10.6	Alternating-current generators	59	17.7	Electric propulsion plant generators	82
10.7	Direct-current generators	60	17.8	Electric propulsion plant switchboards	83
10.8	Electromagnetic brakes	60	17.9	Electric propulsion plant power transformers	83
10.9	Asynchronous electric motors supplied from frequency converters	60	17.10	Electric propulsion plant semiconductor converters	84
11	Transformers.	61	17.11	Protection Arrangements for Harmonic Filters	84
11.1	General	61	17.12	Electric propulsion motors	85
11.2	Overload, voltage variation and operation in parallel	61	17.13	Special requirements for podded Azimuth Thruster Drives and Steerable propeller drives	85
12	Power semiconductor units	62	17.14	Electric propulsion plants control systems	87
12.1	General	62	17.15	Electric couplings	88
12.2	Permissible parameters of voltage distortion	62	18	Additional requirements for electrical equipment designed for a voltage in excess of 1000 V up to 15 kV.	91
12.3	Control and signalling systems	62	18.1	General	91
12.4	Measuring instruments	62	18.2	System design	91
13	Accumulator batteries	63	18.3	Electrical machines	93
13.1	General	63	18.4	Power transformers	93
13.2	Arrangement of accumulator batteries	63	18.5	Cables	94
13.3	Heating	64	18.6	Switchgear and controlgear assemblies	94
13.4	Ventilation	64	18.7	Installation	95
13.5	Charging of accumulator batteries	64	19	Requirements for electrical equipment proceeding from ship purpose.	97
13.6	Installation of electrical equipment in battery compartments	64	19.1	Passenger ships	97
13.7	Electrical starters for internal combustion engines	64	19.2	Oil tankers and oil recovery ships	100
			19.3	Ships intended for carriage of motor vehicles with fuel in their tanks including compressed hydrogen or national gas for their propulsion	103

19.4	Special purpose ships	103	20.4	Lighting	114
19.5	Container ships	105	21	Spare parts	115
19.6	Catamarans	106	22	Special requirements to electrical equipment	
19.7	Floating cranes and crane ships	106		of ship's electric power system with electrical	
19.8	Floating docks	106		power distribution for direct current	116
19.9	Berth-connected ships	110	22.1	General	116
19.10	Fishing vessels	110	22.2	Connection systems of electric	
19.11	Ships carrying dangerous goods	111		power supply units	116
20	Requirements for electrical equipment of		22.3	Electrical power distribution.	116
	refrigerating plants	114	22.4	Protection devices	116
20.1	General.	114	22.5	Electrical machines	116
20.2	Power supply and switching	114	22.6	AC power supply consumer transformers	117
20.3	Ventilation	114	22.7	Electrical power converters	117

PART XI. ELECTRICAL EQUIPMENT

1 GENERAL

1.1 APPLICATION

1.1.1 The requirements of the present Part of the Rules apply to electrical installations in ships subject to the Register survey, as well as to individual types of electrical equipment in accordance with 1.3.

1.1.2 It is recommended that the relevant requirements of the present Part shall be also applied to electrical equipment, which is installed in ships not specified in 1.3.2 and 1.3.3.

1.2 DEFINITIONS AND EXPLANATIONS

1.2.1 Definitions and explanations relating to the general terminology of the Rules are given in Part I "Classification".

For the purpose of the present Part of the Rules the following definitions and explanations have been adopted.

Emergency lighting is lighting of ship's spaces and zones by means of lighting fixtures fed from the emergency source of power or from the transitional emergency source of power.

Emergency source of electrical power is a source of electrical power intended to supply necessary ship's services in case of power failure on the main switchboard.

Emergency transitional source of electrical power is a source of electrical power intended to supply necessary ship's services from the moment of the power failure on the main switchboard busbars until the emergency generator is switched on to supply the emergency switchboard busbars.

Emergency switchboard is a switchboard intended to be supplied directly from the emergency or emergency transitional source of electrical power in case of failure of the main source of electrical power and to supply the emergency services.

Antistatic earthing is electrical connection to ensure grading of static electricity potentials of the structural parts of equipment and ship's hull due to their direct contact or through antistatic earthing conductors.

The antistatic earthing conductors are:

metal conductors connecting equipment subject to antistatic earthing, cable shields, piping, etc, to one another and/or to ship's hull or other equipment earthed;

layers of conductive substances applied onto equipment surfaces, such as: metal coatings, con-

ductive plastics, compounds, mastics, antistatic paint coatings, etc.

Safety voltage is any voltage not dangerous to the personnel. This condition is considered to be satisfied if the windings of transformers, converters, and other devices to step down voltage are electrically separated and if the value of stepped-down voltage across these devices or sources of electrical power does not exceed:

50 V between poles for direct current;

50 V between phases or between phases and the ship's hull for alternating current.

Shaft generators are generators driven by the main machinery and supplying the ship's mains or separate consumers.

Galvanic intrinsic safety is such a state of the ship equipment and systems, under which the possibility of fire or explosion due to electric sparking in case of galvanic contact of the ship with a shore structure or another ship caused by electrochemical phenomena and stray currents in surrounding sea water and ground is excluded.

Main switchboard is a switchboard intended to be supplied directly from the main source of electrical power and to supply the ship services.

Earthing is electrical connection of a part of electrical equipment to be earthed to ship's hull.

Lightning protection zone is the area, within the limits of which the ship's space is protected against direct lightning strokes.

Uninterruptible power system (UPS) is combination of converters (rectifier-inverter), switches (bypass) and energy storage means, for example, batteries, constituting a power system for maintaining continuity of load power in case of input power failure.

Competent body is an organization possessing appropriate knowledge and experience in a specific area, which documents are recognized by the Register.

Ship's hull means all ship's metal parts, which have a reliable electrical connection to the outer metal shell plating. For ships with non-conducting hull, it is a special copper sheet with the area of not less than 0,5 m² and the thickness not less than 2 mm, which is fixed to the outside of the ship's shell plating at a level below the light load waterline and is used for earthing all the equipment installed on board the ship.

Air termination network is the upper part of the lightning protection device intended for the perception of atmospherics.

Non-essential services are services, the temporary disconnection of which does not impair the safety of navigation, the safety of human life and the safety of cargo on board.

Main electrical power plant is a space where the main source of electrical power is placed.

Main electrical power source is a source of electrical power intended to supply all electrical equipment and systems essential for maintaining the ship in normal operational and habitable condition, without resorting to the emergency source of electrical power.

Essential services are services normal operation whereof ensures safe navigation, safety of human life and safety of cargo on board ship; essential services are divided into primary and secondary services.

Primary essential services are the services, which need to be in continuous operation to maintain propulsion and steering of the ship. Such services are those listed in 1.3.2.1.

Secondary essential services are the services, which need not necessarily be in continuous operation to maintain propulsion and steering but which are necessary for maintaining the ship safety. These services shall be ready for the immediate activation. Such services are those listed in 1.3.2.2.

Down conductor is a conductor, which electrically connects the air termination network to the earth termination network.

Special electrical spaces are spaces or locations intended expressly for electrical equipment and accessible only to operating personnel.

Not readily ignitable electrically insulating material is a material, which sustains the tests specified in the Rules for Technical Supervision during Construction of Ships and Manufacture of Materials and Products for Ships.

Electrical installation of low power is an electrical installation of a ship with the total power of supply sources up to 50 kW (kVA).

Electrostatic intrinsic safety is such a state of the ship equipment and systems, under which the possibility of fire or explosion due to static electricity discharges is excluded.

1.3 SCOPE OF SURVEYS

1.3.1 General.

General provisions applicable to the classification procedure, survey during ship's construction and manufacture of the equipment are stated in the General Regulations for the Classification and Other Activity and in Part I "Classification".

1.3.2 Survey of ship's electrical equipment.

Main and emergency sources of electrical power, power and lighting transformers and converters (both rotating and static), main and other switchboards, cable network, as well as electrical equipment, systems and arrangements listed in 1.3.2.1 to 1.3.2.4 are subject to survey on board the ship.

1.3.2.1 Primary essential services are:

- .1 steering gear;
- .2 pumps of hydraulic systems of CP-propellers;
- .3 scavenging air blower, fuel oil supply pumps, fuel valve cooling pumps, lubricating oil pumps and cooling water pumps for main and auxiliary engines and turbines necessary for propulsion;
- .4 forced draught fans, feed water pumps, water circulating pumps, vacuum pumps and condensate pumps for steam plants on steam turbine ships, and also for auxiliary boilers on ships where steam is used for equipment supplying primary essential services;
- .5 oil burning installations for steam plants on steam turbine ships and for auxiliary boilers where steam is used for equipment supplying primary essential services;
- .6 electrical equipment for azimuth thrusters which are the sole means for propulsion/steering with lubricating oil pumps, cooling water pumps;
- .7 electrical equipment for electric propulsion plant and azimuth electric propulsion plant with lubricating oil pumps, cooling water pumps and forced draught systems;
- .8 electric generators and associated power sources supplying the above equipment;
- .9 hydraulic pumps supplying the above equipment;
- .10 viscosity control equipment for heavy fuel oil;
- .11 navigation lights, aids and signals;
- .12 internal communication devices/systems;
- .13 lighting system;
- .14 control, monitoring, alarm and safety devices/systems for equipment to primary essential services;
- .15 other primary essential services needed to ensure that the ship is used in compliance with its purpose and class notation, as required by the Register.

1.3.2.2 Secondary essential services are:

- .1 windlass;
- .2 fuel oil transfer pumps and fuel oil treatment equipment;
- .3 lubrication oil transfer pumps and lubrication oil treatment equipment;
- .4 pre-heaters for heavy fuel oil;
- .5 starting air and control air compressors;
- .6 bilge, ballast and heeling pumps;
- .7 fire pumps and other fire extinguishing medium pumps;
- .8 ventilating fans for engine and boiler rooms;
- .9 services considered necessary to maintain dangerous spaces in a safe condition, including services for hull earthing on oil tankers, lightning

protection and services ensuring electrostatic and galvanic intrinsic safety;

- .10 fire alarm systems;
- .11 electrical equipment for watertight closing appliances;
- .12 electric generators and associated power sources supplying the above equipment;
- .13 hydraulic pumps supplying the above equipment;
- .14 tunnel and azimuth thrusters;
- .15 inert gas devices/systems in oil tankers;
- .16 control, monitoring, alarm and safety devices/systems for cargo containment systems;
- .17 electric drives for refrigerating plants, specified in 1.1, Part XII "Refrigerating Plants";
- .18 control, monitoring, alarm and safety devices/systems for equipment to secondary essential services;
- .19 other secondary essential services needed to ensure that the ship is used in compliance with its purpose and Class notation, as required by the Register.

1.3.2.3 Services for habitability are those services, which need to be in operation for maintaining the vessel's minimum comfort conditions for the crew and passengers. Examples of equipment for maintaining conditions of habitability are as follows:

- .1 cooking;
- .2 heating;
- .3 domestic refrigeration;
- .4 domestic ventilation;
- .5 sanitary and fresh water;
- .6 electric generators and associated power sources supplying equipment specified in 1.3.2.3.1 to 1.3.2.3.5.

1.3.2.4 Other electrical services are:

- .1 electrical equipment of processing machinery of ships used for processing the living resources of the sea and not engaged in their catching (refer to 19.4.4.1);
- .2 electrical equipment of fishing and processing machinery of fishing vessels (refer to 19.10.1.1);
- .3 other mechanisms and devices not listed above as required by the Register.

1.3.2.5 Electrical equipment of domestic services, as well as the equipment not supplying primary and secondary essential services, including the specified in 1.3.2.4, shall be subject to survey on board the ship only in respect to the following:

- .1 influence exerted by the operation of this equipment on the quality of electrical power produced by the shipboard electrical power plant;
- .2 selection of the types and sections of cables and wires, as well as the methods of cable installation;
- .3 insulation resistance, earthing and protective devices, refer also to 10.1.11, Part V "Technical Supervision during Construction of Ships" of the Rules for Technical Supervision during Construction of Ships and Manufacture of Materials and Products for Ships.

1.3.3 Survey during manufacture of electrical equipment.

1.3.3.1 The following kinds of electrical equipment intended for use in installations and systems listed in 1.3.2 are subject to survey during manufacture:

- .1 generating sets;
- .2 electric machines;
- .3 transformers;
- .4 switchboards;
- .5 control and monitoring panels;
- .6 electric slip couplings and brakes;
- .7 apparatus and devices for electrical protection, starting, control and switching;
- .8 apparatus and devices of internal communication and signalling;
- .9 power semiconductor converters and other similar power units;
- .10 fuel and oil heaters;
- .11 accumulator batteries;
- .12 cables and wires;
- .13 fixed electrical measuring instruments;
- .14 electrical apparatus and facilities to measure non-electrical values;
- .15 space heating and cooking appliances;
- .16 lighting switches and accessories;
- .17 stationary lighting fixtures;
- .18 control and monitoring devices;
- .19 other equipment not listed above as required by the Register.

1.3.3.2 The safe type electrical equipment shall be surveyed (with respect to its safety) by a competent authority whose documents are recognized by the Register, irrespective of whether or not this equipment is subject to survey according to the requirements of 1.3.3.1.

1.3.3.3 Scope of tests of electrical equipment after manufacture and requirements for tests are given in the Rules for Technical Supervision during Construction of Ships and Manufacture of Materials and Products for Ships.

1.4 TECHNICAL DOCUMENTATION

1.4.1 General provisions applicable to the procedure of approval of technical documentation are set forth in the General Regulations for the Classification and Other Activity. The scope of technical documentation on electrical equipment for the entire ship to be submitted to the Register for consideration is stated in 3.2, Part I "Classification".

1.4.2 Prior to starting the survey of the electrical equipment manufacture, the following documentation shall be submitted to the Register for consideration:

.1 description of the principle of operation and main characteristics;

.2 specification (list of items), which indicates all the components, instruments and materials used and their technical characteristics;

.3 general view drawing with sectional views;

.4 circuit diagram;

.5 programme of tests;

.6 results of rotor shaft (armature) calculation and drawing of fastening of poles, active iron core, commutator, etc., as well as welded joints of the spoke rib and the shaft, for electric machines with rated current in excess of 1000 A;

.7 busbar calculation of electrodynamic and thermal short circuit strength — for switchboards, if rated current of the generators operating separately or total current of the generators operating in parallel exceeds 1000 A;

.8 data concerning immunity to static or dynamic interference or method of electromagnetic compatibility testing;

.9 measures to be taken for interference suppression.

When necessary, the Register may require supplementary technical documentation and data on reliability to be submitted.

2 GENERAL REQUIREMENTS

2.1 OPERATING CONDITIONS

2.1.1 Influence of climatic conditions.

2.1.1.1 The rated ambient air and cooling water temperatures for electrical equipment shall be those specified in Table 2.1.1.1.

2.1.1.2 Electrical equipment shall be capable of reliable performance at a relative air humidity of 75 ± 3 % and a temperature of $+45 \pm 2$ °C or at a relative air humidity 80 ± 3 % and a temperature of $+40 \pm 2$ °C, as well as at a relative humidity of 95 ± 3 % and a temperature of $+25 \pm 2$ °C.

2.1.1.3 Where electrical equipment is installed within environmentally controlled spaces the ambient temperature, for which the equipment shall be suitable, may be reduced as against the value given in Table 2.1.1.1 and maintained at a value not less than $+35$ °C, provided:

.1 the equipment is not for use for emergency services and is located outside the machinery spaces;

.2 temperature control is achieved by at least two cooling units so arranged that in the event of loss of one cooling unit, the remaining unit is capable of satisfactorily maintaining the design temperature;

.3 the equipment installed in such spaces shall be able to work safely at temperature of $+45$ °C until the nominal working ambient temperature may be achieved; the cooling equipment shall be rated for $+45$ °C ambient temperature;

.4 audible and visual alarms shall be provided at a continually manned control station to indicate any malfunction of the cooling units.

2.1.2 Mechanical effects.

2.1.2.1 Electrical equipment shall be capable of reliable performance at vibrations with frequency of 2 to 80 Hz, i.e. with an amplitude of displacements of ± 1 mm for frequency range of 2 to 13,2 Hz and an acceleration of $\pm 0,7$ g for frequency range of 13,2 to 80 Hz.

Electrical equipment located on the sources of vibrations (diesel engines, compressors, etc.) or in the steering gear room shall be capable of reliable performance at vibrations of 2 to 100 Hz, i.e. with an amplitude of displacement of $\pm 1,6$ mm for frequency range of 2 to 25 Hz and an acceleration of $\pm 4,0$ g for frequency range of 25 to 100 Hz.

Electrical equipment shall also be capable of reliable performance at shocks having an acceleration of $\pm 5,0$ g and at a frequency of 40 to 80 shocks per minute.

2.1.2.2 Electrical equipment shall be capable of reliable performance with the ship having continuous list up to 15° and trim up to 5° , as well as with the ship rolling up to $22,5^\circ$ with period of rolling of 7 — 9 s and pitching up to 10° .

Emergency equipment shall also be capable of functioning reliably with the ship having continuous list up to $22,5^\circ$ and trim up to 10° , or within the same limits of simultaneous list and trim.

In gas carriers and chemical tankers, the emergency electrical power sources shall be capable of reliable performance with the ship having list up to 30° .

2.1.2.3 Electrical equipment shall possess the relevant mechanical strength and shall be so located as to avoid the risk of mechanical damage (refer also to 2.7.4).

2.1.3 Permissible variations of supply parameters.

2.1.3.1 Electrical equipment shall be so designed that it remains operative in all cases, except as noted in 10.8.2, 14.1.3.2 to 14.1.3.3 at all variations from the supply voltage and frequency as specified in Table 2.1.3.1 (refer also to 3.1.2.2 and 16.8.3.3).

2.1.3.2 On ships of restricted area of navigation R3, it is allowed (except for in machinery and devices of essential services) to use the electrical equipment (of general commercial type) not fully complying with the above requirements.

Table 2.1.1.1

Nos	Location of equipment	Ambient air and cooling water temperature, °C			
		Unrestricted service		Navigation outside the tropical zone	
		Air	Water	Air	Water
1	Machinery and special electrical spaces, galleys	+45 ... 0	+32	+40 ... 0	+25
2	Weather decks	+45 ... -25	—	+40 ... -25	—
3	Other spaces	+40 ... 0	—	+40 ... 0	—

Note. Electronic elements and devices designed for mounting in the switchboards, panels or casings shall be capable of reliable performance at an ambient air temperature up to 55 °C.
Temperature up to 70 °C shall not lead to failure of the elements, devices and systems.

Table 2.1.3.1

Parameters	Variations from rated values		
	for long periods, %	for short periods	
		%	time, s
Voltage (a.c.)	+6...-10	±20	1,5
Frequency	±5	±10	5
Voltage (d.c.)	±10	5 10	cyclic variations ripple

Note. When the services are fed from accumulator battery:
 long-period voltage variation within + 30 to -25 % for the equipment fed from the accumulator battery connected to the charging unit;
 long period voltage variation within + 20 to -25 % for the equipment, which is not connected to the charging unit.

2.2 ELECTROMAGNETIC COMPATIBILITY

2.2.1 General.

2.2.1.1 The present requirements are applicable to electrical equipment and automation equipment to ensure electromagnetic compatibility on board.

2.2.1.2 Failure-free performance of the equipment shall be ensured under conditions of interference having the following parameters:

.1 static and variable (50 Hz) magnetic field in accordance with Table 2.2.1.2.1.

Table 2.2.1.2.1

Class of equipment	Intensity, A/m	
	static field	variable field (50 Hz)
1	100	100
2	400	400
3	1000	1000

Installation of equipment is permitted:

class 1 — at a distance of 2 m and more from a powerful field source (busbar, group transformer);

class 2 — at a distance of 1 m and more from a powerful field source;

class 3 — irrespective of the distance from field source of any kind;

.2 harmonic components of voltage in supply circuits in accordance with the higher harmonics diagram for ship mains to be found in Fig. 2.2.1.2.2 on a logarithmic scale;

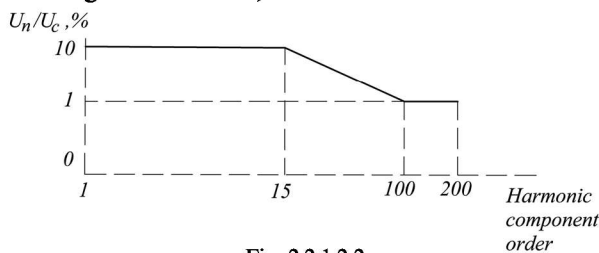

Fig. 2.2.1.2.2

Diagram of higher harmonic components for ship mains

.3 electrostatic discharges with a voltage amplitude of 8 kV;

.4 radio frequency electromagnetic fields within a range of 80 MHz — 2 GHz with a root-mean-square value of field intensity of 10 V/m;

.5 nanosecond voltage pulse with an amplitude of 2 kV for the power supply and of 1 kV for signalling and control cables with a duration of 5/50 ns;

.6 radio frequency interference in conductivity circuits within a range of 150 kHz to 80 MHz with a root-mean-square voltage of 3 V and 80 % modulation at a frequency of 1 kHz;

.7 microsecond voltage pulse in supply circuits with an amplitude of 1 kV for symmetrical pulse feed and of 2 kV for non-symmetrical pulse feed with a duration of 1,2/50 μs.

2.2.1.3 The voltage curve harmonic distortion factor shall not exceed 10 % and shall be determined by the formula

$$K_u = \frac{1}{U_c} \sqrt{\sum_{n=2}^{200} U_n^2} \cdot 100 \% \quad (2.2.1.3)$$

where U_c = actual circuit voltage;
 $U_n = n$ — harmonic component voltage;
 n = higher harmonic component order.

The value of K_u is specified for the complete electrical power system of a ship.

On special agreement with the Register, busbars with $K_u > 10$ % may be used for power supply to powerful sources of the harmonic components of voltage and to electrical equipment not sensitive to such harmonic components, provided that the busbars are connected to the main busbars through isolating devices (refer to 2.2.2.2).

2.2.1.4 The intensity levels of radio interference from equipment in the power supply circuits shall not exceed the following values within the frequency bands given below:

for the equipment installed on open deck and navigation bridge:

10 — 150 kHz — 96 — 50 dBμV/m;

150 — 350 kHz — 60 — 50 dBμV/m;

350 kHz — 30 MHz — 50 dBμV/m;

for the equipment installed in machinery and other enclosed spaces:

10 — 150 kHz — 120—69 dBμV/m;

150 — 500 kHz — 79 dBμV/m;

500 kHz — 30 MHz — 73 dBμV/m.

Artificial mains network and quasi-peak measuring receiver shall be used for measuring the intensity level of radio interference. The receiver bandwidth when measurements are taken within the frequency band from 10 to 150 kHz shall be 200 Hz and within the frequency band from 150 kHz to 30 MHz — 9 kHz.

2.2.1.5 On ships, for which the level of radio interference from power semiconductor converters cannot be limited in conformity with 2.2.1.4, the mains of automation, radio and navigational equipment shall be galvanically isolated from the mains of those converters so that at least 40 db are damped within the frequency range 0,01 — 30 MHz.

The power supply cables of equipment having the radio interference levels in excess of those stipulated by 2.2.1.4 shall be laid at least 0,2 m away from the cables of other equipment groups where the common cable run is longer than 1 m (refer to 2.2.2.8).

2.2.1.6 The levels of the radio interference electromagnetic field induced at a distance of 3 m from the equipment shall not exceed the following values within the frequency bands given below:

for the equipment installed on open deck and navigation bridge:

150 — 300 kHz — 80 — 52 dB μ V/m;

300 kHz — 30 MHz — 52 — 34 dB μ V/m;

30 — 2000 MHz — 54 dB μ V/m, except for the band 156 — 165 MHz where the level shall be equal to 24 dB μ V/m.

for the equipment installed in machinery and other enclosed spaces:

150 kHz — 30 MHz — 80 — 50 dB μ V/m;

30 — 100 MHz — 60 — 54 dB μ V/m, except for the band 156 — 165 MHz where the level shall be equal to 24 dB μ V/m.

Quasi-peak measuring receiver shall be used to take measurements. The receiver bandwidth within the frequency band from 150 kHz to 30 MHz and from 156 to 165 MHz shall be 9 kHz and within the frequency band from 30 to 156 MHz and from 165 MHz to 1 GHz — 120 kHz.

2.2.2 Measures to ensure electromagnetic compatibility.

2.2.2.1 To ensure protection of radio equipment against electromagnetic interference, the requirements of Part IV "Radio Equipment" of the Rules for the Equipment of Sea-Going Ships shall be considered.

2.2.2.2 For the purpose of dividing the power supply of the ship, rotary converters, special transformers and filters shall be used.

2.2.2.3 Power cable screens or metal armour shall be connected to the metal casing of relevant equipment and shall be earthed as frequently as possible, at each end as a minimum.

2.2.2.4 The screens of signal cables shall be earthed at one point on the side of the initial signal processing block. The cable shall have an external insulating sheath.

2.2.2.5 Continuous screening shall be ensured, and for this purpose cable screens shall be connected to equipment casings, and it shall also be ensured in

cable branch boxes and cable distribution boxes, and in way of cable penetrations through bulkheads.

2.2.2.6 The earthing installed for the purpose of interference protection shall have an electric resistance not greater than 0,02 ohm, minimum length possible, shall be resistant to vibration and corrosion, and shall be readily accessible for inspection.

2.2.2.7 Cable screens shall not be used as return conductors.

2.2.2.8 By the type of signals conveyed, ship cables are subdivided in groups as follows:

.1 coaxial cables of radio receivers and conveying video signals with the level of signals 0,1 μ V to 500 μ V;

.2 screened or coaxial cables conveying analogue or digital signals with a level 0,1 to 115 V;

.3 screened cables of telephone and radio broadcasting apparatus, control and signalling network with the level of signals 0,1 to 115 V;

.4 unscreened and located below the deck or screened and located above the deck cables of power and lighting network with the level of signals 10 to 1000 V;

.5 coaxial or screened cables of the transmitting aeriels of radio transmitters, radar installations and echo sounders, power semiconductor converters with the level of signals 10 to 1000 V.

2.2.2.9 Cable of the same group may be laid in the same cable run provided interference-sensitive equipment is not influenced by the difference in the levels of signals conveyed. Where cable lengths laid in parallel are in excess of 1 m, the cables (cable runs) of different groups shall be laid at least 0,1 m apart and their intersections shall be effected at right angles. The radar installation and echo sounder cables mentioned in 2.2.2.8.5 shall either be double-screened or, if they are coaxial, laid inside a metal pipe. The outer screen shall be earthed, as well as the principal screen of the cable.

2.2.2.10 When electrical equipment is installed or cables are laid in the vicinity of magnetic compasses and to ensure protection against interference from other navigational equipment, the requirements of Part V "Navigational Equipment" of the Rules for the Equipment of Sea-Going Ships and Appendices 1 and 2, Section 16, Part V "Technical Supervision during Construction of Ships" of the Rules for Technical Supervision during Construction of Ships and Manufacture of Materials and Products for Ships shall be considered.

2.2.2.11 On all ships constructed from non-conductive materials, for which radio equipment is required by the Rules, all cables located within 9 m from the aeriels shall be shielded or otherwise protected from radio interference, and all the equipment on board those ships shall be fitted with devices for radio interference suppression.

2.3 MATERIALS

2.3.1 Structural materials.

2.3.1.1 The structural parts of electrical equipment shall be fabricated of durable materials not containing asbestos, rated at least as having low flame-spread characteristics, resistant to sea air, oil and fuel vapour effects, or reliably protected against such effects.

For equipment installed or intended for use in dangerous spaces and zones, the structural parts of electrical equipment shall be fabricated of materials ensuring electrostatic and galvanic intrinsic safety.

2.3.1.2 Screws, nuts, hinges and similar items designed to fasten enclosures of the electrical equipment to be installed on weather decks or in spaces with increased humidity shall be made of corrosion-resistant materials or have effective corrosion-resistant covering.

2.3.1.3 All current-carrying parts of electrical equipment shall be of copper, copper alloys or other materials of equivalent qualities, with the exception of:

.1 rheostat elements, which shall be made of mechanically strong materials having high resistivity and capable of withstanding high temperatures;

.2 short-circuit rotor windings of asynchronous and synchronous motors, which may be made of aluminium or its alloys resistant to sea conditions;

.3 carbon brushes, cermet contacts and other similar parts when the properties specified so require;

.4 parts of electrical equipment directly connected to the ship's hull in case of hull-return single-wire system;

.5 aluminium windings of high-voltage transformers in compliance with 18.4.1.6.

2.3.2 Insulating materials.

2.3.2.1 Insulating materials of live parts shall not contain asbestos and shall have adequate dielectric strength and resistance to creepage currents, moisture and oil, as well as sufficient mechanical strength, or else be suitably protected.

The heating temperature of current-carrying parts and their connections shall not exceed the permissible heating temperature of the insulating materials at the rated load.

2.3.2.2 Non-flammable liquids may be used for cooling uninsulated parts of electrical equipment.

2.3.2.3 The insulating materials used for winding insulation in machines, apparatus and other equipment for essential services shall comply with the agreed standards.

The use of insulating materials not inferior to Class E is recommended.

2.3.2.4 Conductors used in electrical devices for internal connections shall have insulation made of materials rated at least as having low flame-spread characteristics and for apparatus with increased

heating and also indicated in Section 15 — of non-combustible materials.

2.3.2.5 For insulation materials used for the manufacture of cables, refer to 16.3.

2.4 STRUCTURAL REQUIREMENTS AND PROTECTION OF ELECTRICAL EQUIPMENT

2.4.1 General.

2.4.1.1 Such parts as require replacement while in service shall be easily dismantlable.

2.4.1.2 Where screw fastenings are employed, provision shall be made to exclude self-loosening of screws and nuts or, where dismantling and opening are a frequent occurrence, loss of same.

2.4.1.3 Gaskets used in components of electrical equipment (such as doors, covers, sight holes, packing glands, etc.) shall ensure adequate protection when in service.

The gaskets shall be secured to the covers or casings.

2.4.1.4 If the casings, panels and covers of electrical equipment, installed where unspecialized personnel has access to it, render live parts inaccessible, they shall be opened with tools only.

2.4.1.5 Suitable water drainage arrangements shall be provided in electrical equipment where condensation is likely to occur. Channels shall be fitted inside the equipment to provide for condensate drainage from all equipment components. The windings and live parts shall be so arranged or protected that they are not exposed to the effects of such condensate as may accumulate inside the equipment.

2.4.1.6 Electrical equipment with forced ventilation, designed for installation in bottom parts of damp spaces, shall be provided with a ventilation system so as to avoid, as far as possible, suction of moisture and oil vapours inside the equipment.

2.4.1.7 Where measuring instruments with oil, steam or water supply are fitted in the control panel or desk, measures shall be taken to prevent these agents from making contact with the live parts in case of damage to the instruments or pipelines.

2.4.2 Insulation clearances.

Clearances between live parts at different potentials, or between live parts and earthed metal parts or outer enclosure, both in air and across the insulant surface shall be in conformity with the operating voltage and operating conditions of the installation, with the properties of the insulating materials used duly taken into account.

2.4.3 Internal wiring.

2.4.3.1 Stranded wires shall be used for internal wiring of electrical equipment throughout. Hookup wires shall be marked according to connection diagram.

2.4.3.2 For internal wiring of switchboards, control desks, other distribution and switching arrangements, etc., wires of not less than 1 mm² in cross-sectional area shall be used.

For systems of control, protection, measurement of different parameters, signalling and internal communication the use of wires having a cross-sectional area not less than 0,5 mm² is permitted.

For electronic and electrical devices for transformation and transmission of low-power signals wires not less than 0,2 mm² in cross-sectional area may be used.

2.4.3.3 Current-carrying parts shall be so attached that they will not have to sustain any additional mechanical stresses; such parts shall not be attached by screws fitted directly into insulating materials.

2.4.3.4 Stranded cores, cables and wires shall have their ends fitted out to suit the type of terminal used, or shall be provided with lugs.

2.4.3.5 Insulated wires shall be laid up and secured in such a manner that the method used for their attachment and arrangement does not lead to reduced insulation resistance and that they are not exposed to damage due to electrodynamic loads, vibrations or shocks.

2.4.3.6 Arrangements shall be made to ensure that the temperatures allowed for insulated wires under normal service conditions or for the duration of short-circuit current breaking are not exceeded.

2.4.3.7 Insulated wires shall be so connected to terminals or busbars that the wire insulation shall not be exposed to the overheating temperature under rated operating conditions.

2.4.4 Protection of electrical equipment.

2.4.4.1 Depending on location, the use shall be made of electrical equipment in appropriate protective enclosure, or other suitable measures shall be taken to protect the equipment from harmful effect of the environment and to protect the personnel from electric shock hazards.

2.4.4.2 The minimal degree of protection of electrical equipment installed in ship's spaces and zones shall be chosen from Table 2.4.4.2.

2.5 PROTECTIVE EARTHING OF METAL PARTS, WHICH DO NOT CARRY CURRENT

Metal enclosures of electrical equipment operated at a voltage exceeding the safety level or having no double or reinforced insulation shall be fitted with an earth terminal marked with the symbol ⊥.

Provision shall be made for earthing inside and outside of the electrical equipment enclosure dependent on its purpose.

2.5.1 Parts to be earthed.

2.5.1.1 Metal parts of electrical equipment, which are likely to be touched under service conditions and which may become live in the event of damage to the insulation (except for those mentioned under 2.5.1.2), shall have a reliable electric contact with a component fitted with an earth terminal (refer also to 2.5.3).

2.5.1.2 Protection earthing is not required for:

.1 electrical equipment supplied with current at safety voltage;

.2 electrical equipment provided with double or reinforced insulation;

.3 metal parts of electrical equipment fastened in non-conducting material or passing therethrough and separated from the earthed and live parts in such a manner that under normal operating conditions these parts cannot become live or come in contact with earthed parts;

.4 bearing housings isolated to guard against circulating currents;

.5 lamp caps and fasteners for luminescent lamps, lamp shades, reflectors and guards supported on lamp holders or lighting fixtures constructed of, or shrouded in non-conducting material;

.6 cable clips, cleats, etc.;

.7 individual consumer — under voltage up to 250 V supplied through an isolation transformer.

2.5.1.3 The shields and metal armour of cables shall be earthed.

2.5.1.4 The secondary windings of all instrument transformers for current and voltage shall be earthed.

2.5.2 Earthing of aluminium structures in steel ships.

Superstructures of aluminium alloys fastened to the ship steel hull but insulated therefrom shall be earthed by at least two special wires, which will not start electrolytic corrosion at the points of their contact with the superstructure and the hull. The conductivity of each wire shall not be lower than the equivalent conductivity of a copper wire having a cross-sectional area of 16 mm². Such earthing connections shall be provided at different locations around superstructure perimeter, shall be accessible for inspection and protected from damage.

2.5.3 Earth terminals and conductors.

2.5.3.1 Bolts for fastening the earthing conductor to the ship's hull shall have a diameter not less than 6 mm. For cables and wires having a cross-sectional area of 2,5 mm² and 4 mm² it is permitted to use bolts (screws) 4 mm and 5 mm in diameter, respectively. Such bolts shall not be used for other purposes.

The bolts screwed into material (without nuts) shall be manufactured of brass or other corrosion-resistant material.

Table 2.4.4.2

Spaces, in which electrical equipment is installed	Type of electrical equipment					
	Electric machines, transformers	Switchboards, control gear, starters	Communication and signalling equipment, automation equipment, accessories (switchers, sockets, junction boxes)	Space heating and cooking appliances	Lighting fixtures	
Spaces and zones, in which explosive mixtures of vapours, gases or dust with air are likely to occur	<i>Ex</i> (refer to 2.9, 19.2.4)	—	<i>Ex</i> (refer to 2.9, 19.2.4)	—	<i>Ex</i> , (refer to 2.9, 19.2.4)	
Dry spaces, dry accommodation spaces	IP20	IP20	IP20	IP20	IP20	
Navigation bridge, radio room	IP22	IP22	IP22	IP22	IP22	
Service spaces, steering gear rooms, refrigerating plant rooms (except for ammonia equipment), emergency diesel generator rooms, general purpose stores. Pantries, provision stores	IP22	IP22	IP22	IP22	IP22	
Engine and boiler rooms	Above plating	IP22	IP22	IP44	IP22	IP22
	Below plating	IP44	—	IP44	IP44	IP44
	Control stations (dry)	IP22	IP22	IP22	IP22	IP22
	Enclosed separator rooms	IP44	IP44	IP44	IP44	IP44
	Premises and spaces protected by the fixed local application fire extinguishing systems ¹	IP44	IP44	IP44	IP44	IP44
Refrigerated spaces, galleys, laundries, bathrooms and showers	IP44	IP44	IP55	IP44	IP44	
Catch processing spaces ² , shafting tunnels, cargo holds	IP55	IP55	IP55	IP55	IP55	
Open decks	IP56	IP56	IP56	IP56	IP56	
¹ The electrical equipment within adjacent areas not exposed to direct spray, upon agreement with the Register may have a lower degree of protection provided relevant measures of the electrical equipment protection are taken (e.g. installation of extra inlet ventilation openings, filters, baffles, etc). ² For the electrical equipment installed in the catch processing spaces an additional protection is recommended to enable sanitization of the equipment with sea water. Note. Where the enclosure of equipment does not guarantee the necessary protection, alternative methods of protection or alternative arrangement of equipment shall be applied to ensure the degree of protection stipulated by the Table.						

Ship's hull in places of earthing conductor connections shall be cleaned to metal and properly protected against corrosion.

2.5.3.2 Fixed electrical equipment shall be earthed by means of external earthing conductors or an earthing core in the feeding cable.

When earthing is effected with a special core of the feeding cable, it shall be connected to the earthing device inside the enclosure of the electrical equipment.

Such earthing effected with external earthing conductors need not be provided in case the arrangement of equipment ensures a reliable electrical contact

between the equipment enclosure and the metal ship's hull under all operating conditions.

For earthing effected with an external earthing conductors, the use shall be made of copper conductors, as well as conductors of any other corrosion-resistant metal provided the resistance of these conductors does not exceed that of the required copper conductor. The cross-sectional area of copper earthing conductor shall not be less than that specified in Table 2.5.3.2.

In case earthing is effected with a special core, the cross-sectional area of this core shall be equal to the

Table 2.5.3.2

Cross-sectional area of cable core connected to consumer, mm ²	Cross-sectional area of earthing conductor of fixed electrical equipment, mm ² , min	
	solid	stranded
Up to 2,5	2,5	1,5
2,5 to 120	Half the cross-sectional area of cable core connected, but not less than 4	
Over 120	70	

nominal area of the feeding cable core for cables, having a cross-sectional area up to 16 mm² and at least half the cross-sectional area of the feeding cable core, but not less than 16 mm² for cables having a cross-sectional area over 16 mm². Earthing resistance shall not exceed 0,4 Ohm.

2.5.3.3 Earthing of movable, loose and portable consumers shall be effected through and earthed jack in the socket outlet or other earthed contact device and a copper earthing core of the feeding flexible cable. The cross-sectional area of the earthing core shall not be less than the nominal cross-sectional area of the feeding flexible cable core for cables up to 16 mm² and at least half the cross-sectional area of the feeding flexible cable core, but not less than 16 mm², for cables over 16 mm².

2.5.3.4 Earthing of the fixed equipment shall be non-disconnectable.

2.5.3.5 Earthing of shields and metal armour of cables shall be effected in one of the following ways:

.1 using a copper earth wire of a cross-section not less than 1,5 mm² for cable conductors with a cross-sectional area up to 25 mm² and not less than 4 mm² for cable conductors with a cross-sectional area over 25 mm²;

.2 by adequate attachment of the shields and metal armour to the hull;

.3 by means of cable gland rings provided these are characterized by corrosion resistance, good conductivity and elasticity.

Except for cables of end branches of circuit, which may be earthed at the supply end only, earthing can be effected at both cable ends. Cable shields and metal armour may be earthed in another approved way, provided these methods do not hamper the operation of equipment.

2.5.3.6 The external earthing conductors shall be accessible for inspection and protected against getting loose and mechanical damage.

2.6 LIGHTNING PROTECTION

2.6.1 General.

2.6.1.1 In ships provision shall be made for lightning protection devices covering the zone to be protected.

2.6.1.2 In ships, where consequential effects of lightning strokes may cause a fire or explosion, lightning protection earthing devices shall also be fitted to preclude consequential sparking.

2.6.1.3 Lightning protection device shall consist of an air termination, down conductor and earth termination. On metal masts no special lightning protection device need be fitted if provision is made for reliable electrical connection of the mast to the metal hull or earthing point.

2.6.2 Air termination network.

2.6.2.1 In metal ships the ship's vertical structures (masts, derrick posts, superstructures, etc.) may be used as air termination if provision is made for reliable electrical connection of these structures to the metal hull.

Additional air terminations shall be used only when ship's structural elements proper do not provide for reliable lightning protection.

2.6.2.2 If electrical equipment is installed on the top of the metal mast, provision shall be made for an air termination network, which is effectively earthed.

2.6.2.3 On each mast or top mast of non-conducting material an effectively earthed air termination shall be provided.

2.6.2.4 The air termination shall be made of a rod at least 12 mm in diameter. The rod may be of copper, copper alloys or steel protected against corrosion. For aluminium masts aluminium rods shall be used.

2.6.2.5 The air termination shall be fitted to the mast in such a manner that it projects at least 300 mm above the top of the mast or above any device fitted on its top.

2.6.3 Down conductor.

2.6.3.1 The down conductor shall be made of a rod, strip or multiwire cable having a cross-sectional area not less than 70 mm² for copper or its alloys and not less than 100 mm² for steel. Steel down conductors shall be protected against corrosion.

2.6.3.2 Down conductors shall run on the outer side of masts and superstructures with a minimum number of bends, which shall be gradual and have as large radius as possible.

2.6.3.3 Down conductors shall not run through dangerous spaces and zones.

2.6.3.4 In ships with non-metal hull the down conductor of the lightning protection device shall be

laid separately throughout its length (including its connection to the earth termination network), without connecting to the busbars of the protective and operation earthing circuits.

2.6.4 Earth termination network.

2.6.4.1 In composite ships the metal stem or other metal structures immersed in water under any navigation condition may be used as earth termination.

2.6.4.2 Means shall be provided on board the ship to allow for connecting the ship's steel hull or the earth termination network to the shore-based lightning protection device earthing when the ship is in a dock or on a slipway.

2.6.4.3 Earthing of ships with non-conducting hulls shall be in accordance with 1.2 (refer to the definition "Ship's hull").

2.6.5 Connections in lightning protection device.

2.6.5.1 Connections between the air termination network, down conductor and earth termination network shall be welded or bolted with clamps.

2.6.5.2 The contacting surface area between the down conductor, air termination network and earth termination network shall not be less than 1000 mm².

The connecting clamps and connecting bolts shall be made of copper, copper alloys or steel protected against corrosion.

2.6.6 Lightning protection earthing devices.

2.6.6.1 Lightning protection earthing referred to in 2.6.1.2 shall be provided for isolated metal structures, flexible connections, pipes, screens of power and communication lines, pipeline entries into dangerous spaces.

2.6.6.2 All pipelines conveying petroleum products and other pipelines associated with dangerous spaces and zones and located on open decks or in spaces free from electromagnetic screening shall be earthed to the ship's hull at least at 10 m intervals throughout their length.

All pipelines, which are located on the upper deck where explosive gases may be present and which are not associated with dangerous spaces and zones, shall be earthed to the ship's hull at least at 30 m intervals throughout their length.

2.6.6.3 Metal parts near down conductors shall be earthed if they are not fixed to earthed structures and have no other metal connection to the ship's hull. In so doing, facilities or metal parts located at a distance of up to 200 mm from the down conductor shall be so connected to the down conductor that consequential sparking is excluded.

2.6.6.4 The joints of earthing elements shall be accessible for inspection and protected from mechanical damage.

2.7 ARRANGEMENT OF ELECTRICAL EQUIPMENT

2.7.1 Electrical equipment shall be installed in such a manner as to provide convenient access to controls and to all parts that require maintenance, inspection and replacement.

2.7.2 The horizontal-shaft electric machines shall be so installed that the shaft is positioned parallel to the centre line of the ship. Installation of machines with the shaft positioned in another direction is permitted only in those cases when the design of the machine ensures its normal operation under conditions specified in 2.1.2.2.

2.7.3 The air-cooled electrical equipment shall be so located that cooling air is not taken from bilges or other spaces wherein the air may be contaminated with substances having a harmful effect on insulation.

2.7.4 The electrical equipment placed in locations subject to vibration and shocks, which are heavier than those specified in 2.1.2.1 and which are impossible to eliminate, shall be so designed as to ensure its normal operation under these conditions or to mounted on relevant shock absorbers.

2.7.5 Electrical equipment shall be fixed in position in such a manner that the strength of decks, bulkheads and skin is not impaired as a result of this.

2.7.6 No electrical equipment shall be located in spaces wherein explosives are stored. Lighting of such spaces shall be provided with lighting fixtures fitted in adjacent flameproof spaces. If this is impracticable, the electrical equipment shall be of the design and type which prevent potential ignition and explosion.

2.7.7 When the enclosures of electrical equipment are made from different material than the structures on which they are installed, care shall be taken, if necessary, to prevent electrolytic corrosion.

2.8 SPECIAL ELECTRICAL SPACES

2.8.1 The doors of special electrical spaces shall be locked. These doors shall open on the outside.

In case the doors face corridors and passageways in accommodation and service spaces, it is permitted that these doors open on the inside on condition that protection guards and stops are provided. A warning notice shall be placed on the door. From the inside of the space the door shall open without a key.

2.8.2 Special electrical spaces shall not be adjacent to the tanks filled with flammable liquids. If this requirement is not feasible from the structural point of view, measures shall be taken eliminating the possibility of flammable liquid penetration into these spaces.

2.8.3 No exits, side scuttles of the opening type or other openings are permissible from special electrical spaces into dangerous spaces.

2.8.4 Handrails of non-conducting material shall be installed in special electrical spaces, in passage-ways and servicing areas when the open-type electrical equipment is used.

2.9 SAFE-TYPE ELECTRICAL EQUIPMENT

2.9.1 The requirements of the paragraph are applicable to all ships, in which enclosed or semi-enclosed spaces and zones explosive mixtures of vapours, gases or dust with air are likely to occur in dangerous concentrations.

The following spaces and zones fall under this category: paint lockers, lantern rooms (for oil lanterns), storerooms for cylinders with flammable gases, battery compartments and spaces, which contain tanks, machinery and pipes for flammable liquids having a flash point 60 °C and below.

Additional requirements for installation of electrical equipment in oil tankers are specified in 19.2; in ships intended for the carriage of motor vehicles with fuel in their tanks — in 19.3; in ships intended for the carriage of dangerous goods — in 19.11.

2.9.2 Safe type of the equipment shall be confirmed by a certificate issued by a competent body. For simple electrical apparatus and components specified in 19.2.4.1.2 and 19.2.4.2.3, a certificate issued by a competent body as regards safety is not required. The manufacturer's confirmation of the product compliance with IEC 60079-11 and 60079-0 (or equivalent national standards) will be sufficient.

2.9.3 In dangerous spaces and zones, only safe type electrical equipment may be installed, the protection level of which corresponds to the category and group of the most dangerous gas mixture:

.1 paint lockers — sub-group IIB, temperature class T3 (refer also to 2.9.16);

.2 storerooms for cylinders with flammable gases — sub-group IIC, temperature class T2;

.3 battery compartments — sub-group IIC, temperature class T1;

.4 spaces which enclose tanks, machinery and piping for inflammable liquids having a flash point 60 °C and below — sub-group IIB, temperature class T3.

Depth-sounder oscillators and associated cables shall be installed in compliance with the requirements of 3.7.4 and 3.8.3, Part V "Navigational Equipment" of the Rules for the Equipment of Sea-Going Ships, and ventilator motors shall be installed in spaces adapted for the carriage of dangerous cargoes in compliance with 12.7.4, Part VIII "Systems and Piping".

2.9.4 In spaces where explosive mixture of dust or fibre with air may accumulate electrical equipment with the degree of protection not below IP65 shall be installed.

Electrical equipment of IP55 type may be permitted where the occurrence of explosive mixture of dust or fibre with air is temporary, resulting from the damage or infiltration from processing equipment in operation or ventilation cutoff.

Electrical equipment installed in these spaces shall have such protective enclosure that the temperature of its upper horizontal surfaces or those inclined more than 60° to the horizontal is, under conditions of continuous operation, by 75 °C below the smouldering point of dust accumulated in these spaces (the smouldering point shall be determined for a layer of dust 5 mm thick).

2.9.5 Lighting fixtures of safe type shall be so installed that a free space around them is not less than 100 mm, excluding the place of the fastenings.

2.9.6 Any equipment installed in dangerous spaces and zones, except for fire detectors, shall be provided with switches fitted at a safe position outside dangerous spaces and zones to disconnect all live conductors.

2.9.7 Fastening of electrical equipment directly to the walls of tanks intended for flammable liquids is not allowed. In any case, electrical equipment shall be fastened at a distance not less than 75 mm from the tank walls.

2.9.8 In enclosed and semi-enclosed spaces where an explosive mixture of gas or vapour with air is not likely to occur, but direct openings lead to dangerous spaces, electrical equipment of safe type shall be generally installed.

Installation of electrical equipment of non-safe type, is permitted if the following conditions are observed:

.1 operation of alarms (visual and audible) and automatic disconnection of power supply (in sound cases with time delay) to electrical equipment if the ventilation is shut off;

.2 interlocking to provide for possible connection of electrical equipment only after adequate ventilation of the space (at least 10 air changes).

2.9.9 In compartments/holds intended for carriage of flammable cargoes the electrical equipment, which is essential for the safety and control of the ship, shall have a possibility to be completely isolated and protected against unauthorised actuation. The equipment shall be isolated from locations outside the dangerous zones by removing special disconnectors, by switches with interlocking devices or other effective means.

If provision of such equipment is necessary for the safety and control of the ship, the equipment shall be of certified safe type: intrinsically safe (*Exia* or

Exib), pressurised enclosure (*Exp*), flameproof (*Exd*), increased safety (*Exe*).

2.9.10 In explosion-dangerous spaces and zones only the cables serving the electrical equipment fitted in such spaces and zones in full compliance with the requirements of 2.9.11 may be laid. The through runs of cables may be permitted in the above spaces and zones provided the requirements of 2.9.11 - 2.9.15 are complied with. No connections of cables laid in dangerous zones are permitted.

2.9.11 Cables installed in dangerous spaces and zones shall have protective covering of one of the following types:

- .1 metal armour or braid with additional insulation covering;
- .2 lead sheath with additional mechanical protection;
- .3 copper or stainless steel sheath (only for cables with mineral insulation).

2.9.12 Cables passing through dangerous spaces and zones shall be suitably protected against mechanical damage.

Penetrations of cables through decks and bulkheads shall be sealed to avoid ingress of flammable gases or vapours.

2.9.13 All shields and metal braids of cables of power circuits for electric motors and lighting systems, which pass through dangerous spaces and zones or supply the electrical equipment installed in these spaces, shall be earthed at both ends at least.

2.9.14 Cables of intrinsically safe circuits shall not be used for more than one intrinsically safe device and shall be laid separately from other cables.

2.9.15 Cables of portable electrical equipment, except for cables of intrinsically safe circuits, shall not pass through dangerous spaces and zones.

2.9.16 Additional requirements for electrical equipment installed in paint lockers.

2.9.16.1 Electrical equipment shall be installed in paint lockers and in ventilation ducts serving such spaces only when it is essential for operational services.

Safe type equipment of the following type is acceptable: intrinsically safe (*Exi*), pressurized (*Exp*), flameproof (*Exd*), increased safety (*Exe*), special protection (*Exs*).

2.9.16.2 The minimum requirements for the safe type equipment are as follows: explosion group IIB, temperature class T3.

2.9.16.3 In paint lockers and spaces mentioned under 2.9.16.4, cables (through-runs or terminating cables) of armoured type or installed in metallic conduits shall be used.

2.9.16.4 In the areas on open deck within 1 m of inlet and exhaust ventilation openings or within 3 m of exhaust mechanical ventilation outlets, the follow-

ing electrical equipment may be installed: safe type equipment permitted by 2.9.16.1, equipment of protection class (*Exn*), appliances, which do not generate arcs or sparks in service and which surface does not reach unacceptably high temperature under normal conditions.

2.9.16.5 Enclosed spaces giving access to the paint locker may be considered as non-hazardous, provided that:

- .1 the door to the paint locker is a gastight door with self-closing devices without holding-back arrangements;
- .2 the paint locker is provided with an acceptable, independent, natural ventilation system ventilated from a safe area;
- .3 warning notices are fitted adjacent to the paint locker entrance stating that the store contains flammable liquids.

2.10 ANTISTATIC EARTHING

2.10.1 Antistatic earthing is a mandatory mean of ensuring electrostatic intrinsic safety for all types of ships having dangerous spaces and zones.

2.10.2 Equipment to be installed on board, in enclosed and semi-enclosed spaces and zones where explosive mixtures of vapours, gases or dust with air likely to occur (refer to 2.9.1), as well as any portable equipment to be brought and installed in such spaces shall be antistatically earthed.

2.10.3 Bonding straps shall be required for cargo tanks/process plant/piping systems which are not permanently connected to the hull of the ship, e.g.

- .1 independent cargo tanks;
- .2 cargo tanks/piping systems which are electrically separated from the hull of the ship;
- .3 pipe connections arranged for the removal of spool pieces;
- .4 wafer-style valves with non-conductive (e.g. PTFE) gaskets or seals.

2.10.4 The following equipment does not require use of the antistatic earthing conductors:

- .1 fixed and portable electrical equipment shields and metal armour of cables earthed in accordance with 2.5;
- .2 pipes and conduits for installation of cables earthed in accordance with 16.8.8;
- .3 electrical equipment, automation equipment, radio equipment and navigational equipment earthed in accordance with 2.2.2;
- .4 equipment and structures provided with lightning protection earthing in accordance with 2.6.6.

2.10.5 Arrangement and monitoring of antistatic earthing.

2.10.5.1 Where bonding straps are required, they shall be: clearly visible so that any shortcomings can be clearly detected; designed and sited so that they are protected against mechanical damage and that they are not affected by high resistivity contamination e.g. corrosive products or paint; easy to install and replace.

2.10.5.2 Bonding straps shall be connected to the non-metallic equipment, e.g. plastic pipes, in a manner defined by the manufacturer of the equipment. Design of the bonding straps being the component part of the equipment delivered to the ship shall meet the requirements of relevant Parts of the Rules or the standards approved by the Register.

2.10.5.3 Resistance of the antistatic earthing shall be monitored by portable instruments of any type with control d.c. voltage of not more than 10 V. The resistance value measured between the equipment, component, structure being monitored and ship's hull shall not exceed 10^6 Ohm with the area of contact between the measure electrode and the equipment surface being no more than 20 mm^2 .

2.11 ARRANGEMENTS AND SYSTEMS FOR INSULATION RESISTANCE MONITORING

2.11.1 In each isolated ship power system with the nominal voltage above 50 V AC or above 110 V DC provision shall be made for an automatic continuous monitoring of insulation resistance of current-carry-

ing components relative to ship's hull. Measurements periodicity during the periodic monitoring shall not exceed 300 s.

2.11.2 In the networks with the voltage 1000 V and above monitoring of the insulation resistance shall be carried out only alive with the use of passive monitoring methods (for example, with the use of zero-sequence current transformer).

2.11.3 Devices for insulation resistance monitoring in the networks with the voltage up to 1000 V shall:

- be fitted with an indicator showing the insulation resistance value;

- have visible and audible alarm at decrease of controlled value under the prescribed limit;

- allow to perform smooth adjustment of alarm actuating setting value within the range from 100 to 5 kOhm. The current setting value shall be indicated;

- have an operation speed sufficient for measuring insulation resistance value in the networks with the existing capacity level during the measurement cycle of the device which shall not exceed 30 s;

- produce measuring current not exceeding 0,03A under all modes (including transient);

- provide for the possibility of periodic intactness monitoring under operational conditions by means of earth leakage current through an active resistance equal to 80 per cent of resistance of the relevant setting actuating.

2.11.4 Location of devices for insulation resistance monitoring shall meet the requirements of 4.6.4.7.

3 MAIN ELECTRICAL POWER SOURCE

3.1 COMPOSITION AND CAPACITY OF MAIN ELECTRICAL POWER SOURCE

3.1.1 In every ship, a main electric power source shall be provided with a capacity sufficient to supply all the electrical equipment on board under conditions specified in 3.1.5. Such a source shall consist of two independently driven generators at least.

In ships of 300 gross tonnage and below (except for passenger ships), accumulator batteries may be the main power source.

3.1.2 The number and capacity of independently driven generators and electric converters, of which the main electrical power source is composed, shall be such that if any of them failed the rest would ensure:

.1 supply to electrical equipment essential for propulsion, steering and safety of the ship with the normal habitable conditions on board guaranteed;

.2 start of the most powerful electric motor with the greatest starting current. The motor start shall not involve a voltage and frequency drop in the mains that could result in a fall out of synchronism, stop of generator engine or disconnection of machinery and apparatus being in operation;

.3 supply to consumers necessary to start the propulsion plant (refer to 1.2.1, Part VII "Machinery Installation") when the ship is de-energized. For this purpose, emergency electrical power source may be used if its capacity proper or in association with the capacity of any other electrical power source would ensure a simultaneous supply of consumers listed under 9.3.1 to 9.3.3 or under 19.1.2.1 to 19.1.2.3 (refer also to 2.1.6, Part VII "Machinery Installations"), for this purpose their parallel operation may be provided.

3.1.3 Where the main electrical power source is needed to ensure propulsion and steering of the ship, provision shall be made that the power supply to the equipment essential for propulsion and steering and to ensure safety of the ship is maintained continuously or restored immediately in case of failure of any generator being in operation.

Along with that, in ships where electrical power is normally supplied by two or more generators running in parallel, provision shall be made for automatic switching-off of less essential consumers without any overloading of the remaining generators, with retention of power supply to consumers essential for propulsion, steering and to ensure safety of the ship.

In ships where electrical power is normally supplied by one generator, in case of its failure and deenergization of the main switchboard, provision shall be made for:

automatic starting of stand-by generator of sufficient capacity and its connection to busbars of the main switchboard within 30 s;

automatic re-starting, in the necessary sequence, of essential devices ensuring propulsion, steering and safety of the ship.

3.1.4 Instead of one independently driven generator as mentioned under 3.1.1, a generator driven by the main engine (shaft generator) may be used if it complies with 3.2.3 under conditions listed below:

.1 the shaft generator operates practically at a constant speed under different operating conditions of the ship;

.2 provision is made for actuation of the ship's propulsion plant in case of failure of any generator with an independent prime mover.

3.1.5 The number and power output of generators forming the main source of electrical power shall be determined with regard to the following operating conditions of the ship:

.1 running conditions;

.2 manoeuvring;

.3 in case of fire, hole in the ship's hull or other conditions affecting the safety of navigation, with the main sources of electrical power in operation;

.4 other operating conditions according to ship's purpose.

3.1.6 Where accumulator batteries are the main source of electrical power, their capacity shall be sufficient to satisfy the requirements of 3.1.2.1 for 8 hours without recharging; provision shall be made for charging of accumulator batteries from the source of electrical power installed on board.

3.1.7 In ships of restricted area of navigation R3 (except passenger ships) with a low-power electrical installation as the main source of electrical power, only one generator with an independent prime mover or accumulator batteries may be installed.

3.2 GENERATOR SETS

3.2.1 General.

3.2.1.1 Engines designed for use as generator prime movers shall comply with the requirements set forth in Sections 2, 3 and 8, Part IX "Machinery", and, additionally, with the requirements of the Chapter.

3.2.1.2 Electric machine sets shall be designed for continuous duty, with regard to the power reduction during ship's service under conditions specified in 2.1.1.1.

3.2.1.3 Under short circuit in the ship's mains the generators shall provide for the value of the sustained short-circuit current sufficient for the operation of protective devices.

3.2.1.4 The voltage of generators shall be regulable within the range specified in 10.6 and 10.7 of the present Part, and speed frequency shall be regulable within the range specified in 2.11.3, Part IX "Machinery".

3.2.2 Load sharing between sets running in parallel.

3.2.2.1 Alternating-current sets intended to run in parallel shall be provided with such a reactive-voltage drop compensating system that when the sets run in parallel the reactive load sharing between the generators does not differ from a value proportional to their output by more than 10 % of the rated reactive load of the largest generator involved or by not more than 25 % of the rated output of the smallest generator if this value is lower than the above one.

3.2.2.2 When the alternating-current sets run in parallel at 20 to 100 % of the total load, load sharing shall be within the limits specified in 2.11.3, Part IX "Machinery".

3.2.3 Shaft generator sets.

3.2.3.1 Where shaft generators are used for feeding the ship mains, automatic connection of one or more independently driven generators to the ship mains shall be provided, or an alarm shall be activated in the engine room or at the main machinery control room in case the network frequency is below the permissible value.

3.2.3.2 Shaft generators intended for supply of particular consumers may operate under parameters, which differ from those specified in 3.2.1.4.

3.2.3.3 Shaft generators and semiconductor transducers (inverters) supplying the ship mains shall not be damaged by short circuits at the main distribution board busbars. In this case, a steady short-circuit current shall be ensured, sufficient for protection to be activated.

3.2.3.4 As a minimal requirement, shaft generators shall be designed for short periods of parallel running with other types of generator sets so that manual or automatic (if available) switch-over of the load is possible.

3.2.3.5 For shaft alternators, automatic devices shall be provided to preclude the current overload of their excitation system components when running at a speed below 90 % of the nominal speed during more than 5 s. In this case, a proportional voltage lowering across the generator terminals is permitted.

3.2.3.6 For each shaft generator, a de-excitation device shall be provided at the main distribution board, and measuring instruments as listed under 4.6.4.3.

3.2.3.7 When the shaft generator is connected into the ship mains, a visual warning signal shall be

activated at the navigation bridge indicating that a change in the mode of main machinery operation might bring about a deviation in the ship main parameters beyond the limits stipulated by 10.6 and 10.7 of the present Part and 2.11.3, Part IX "Machinery".

3.2.3.8 A generator with an independent prime mover may be used in shaft generators with semiconductor converters as a synchronous condenser. In such cases, a disengaging clutch shall be fitted between the generator and its prime mover.

3.2.4 Exhaust-heat turbogenerators.

3.2.4.1 Exhaust-heat turbogenerators supplying particular consumers may have performance characteristics different from those stated under 3.2.1.4.

3.2.4.2 The exhaust-heat turbogenerators used for feeding the ship mains shall be designed for parallel operation with generators having an independent prime mover. In this case, the distribution of load between the generator sets shall be in accordance with 3.2.2.

3.3 NUMBER AND CAPACITY OF TRANSFORMERS

3.3.1 In ships, where lighting and other circuits of essential services are powered through transformers, not less than two transformers shall be provided of such a capacity that in case of failure of the largest unit, the remaining transformers are capable of satisfying the complete need in electrical power under all operating conditions of the ship.

Where subdivided system of busbars is used, transformers shall be connected to different sections of the main switchboards.

In ships of less than 300 gross tonnage (other than passenger ships) of restricted areas of navigation **R2, R2-RSN, R2-RSN(4,5), R3-RSN** and **R3**, with the electrical installation of low power installation of only one transformer is allowed.

3.4 POWER SUPPLY FROM AN EXTERNAL SOURCE OF ELECTRICAL POWER

3.4.1 If provision is made for ship's mains to be supplied from an external source of electrical power, an external supply switchboard shall be installed in the ship (refer also to 4.6.4.6).

For ships with the electrical installation of low power it is allowed that cables for supply of the ship's mains from an external source of electrical power shall be connected to the main switchboard directly.

3.4.2 At the external supply switchboard, the following facilities shall be provided:

.1 terminals for flexible cable connection;

.2 switch gear and protection devices for connecting and protection of permanently laid cable of the main distribution switchboard; where the cable length between the external supply switchboard and the main distribution switchboard is less than 10 m, no protection devices may be fitted;

.3 voltmeter or pilot lamps to indicate the presence of voltage from an external source across the terminals;

.4 device or facilities for connecting a device to control polarity and phase sequence;

.5 terminal for earthing a neutral wire from an external source;

.6 plate to indicate voltage, type of current and frequency;

.7 arrangement for mechanical fixation of the end of flexible cable connected to the switchboard and a hanger for the cable, which shall both be provided at the external supply switchboard or in its vicinity.

3.5 CONNECTION OF ELECTRICAL POWER SUPPLY UNITS

3.5.1 Where the electrical power supply units are not adapted for long operation in parallel to feed common busbars, it is necessary to use a connection circuit ensuring their switching-on for parallel operation for the duration of load transfer from one unit to another.

3.5.2 Direct current compound-wound generators designed for parallel operation shall have equalizing connections.

3.5.3 Where alternating-current generators are intended to operate in parallel, a synchronizer shall be installed in the main switchboard.

Where synchronizing is arranged to operate automatically, a standby manual synchronizer shall be provided by one operator.

3.5.4 Where several direct-current generators are installed, a magnetizing device shall be fitted in the main switchboard.

Such device may be also allowed for synchronous alternating-current generators if it is necessary for initial excitation.

3.5.5 Where the ship's and external sources of electrical power are not intended to operate in parallel to the common busbars of the ship's electrical installation, the system of connections shall be so interlocked, in this case, as to prevent their possible switching-on for parallel operation.

3.5.6 Where the main source of electrical power is necessary for propulsion of the ship, the main busbar shall be subdivided into at least two parts, which shall normally be connected by circuit breakers or other approved means (e.g. circuit breaker without release or disconnecter). Bolted links between the main switchboard sections, by which the busbars can be split, are not acceptable.

So far as it is practicable, the connection of generating sets and other duplicated equipment shall be equally divided between the parts.

4 DISTRIBUTION OF ELECTRICAL POWER

4.1 DISTRIBUTION SYSTEMS

4.1.1 The following systems of electrical power distribution are acceptable:

.1 for alternating current up to and including 1000 V:

.1.1 three-phase three-wire insulated system;

.1.2 three-phase three-wire system with neutral earthed through high-value resistor or reactor (compensated-resistor neutral);

.2 additionally for current up to and including 500 V:

.2.1 three-phase four-wire insulated system;

.2.2 three-phase four-wire system with neutral earthed according to 4.1.1.1.2;

.2.3 single-phase two-wire insulated system;

.2.4 single-phase two-wire system with neutral earthed according to 4.1.1.1.2;

.2.5 single-phase single-wire system with hull return for voltage up to 50 V (in ships of less than 1600 gross tonnage), except stated in 6.8.4, provided that any possible current will not pass directly through any of the dangerous spaces;

.3 for direct current:

.3.1 two-wire insulated system;

.3.2 single-wire system with hull return for voltage up to 50 V (in ships of less than 1600 gross tonnage), except stated in 6.8.4, provided that any possible current will not pass directly through any of the dangerous spaces.

Where a hull return system is used, all final circuits shall be two-wire and the insulated return wire shall be earthed by connecting to the earthing busbar of the distribution board supplying the circuit, at the place accessible for inspection. In this case devices shall be provided for isolating the earthing busbars from the hull to test insulation condition.

In ships of 1600 gross tonnage and upwards the use of local earthed systems is accepted for supplying the following consumers (provided that any possible current will not pass directly through any of the dangerous spaces and zones):

.1 electrical (battery) starter systems of internal combustion engines;

.2 impressed-current cathodic protection systems;

.3 insulation resistance monitoring and measuring systems (refer to 4.6.4.7).

4.2 PERMISSIBLE VOLTAGE

4.2.1 Proceeding from the electrical power distribution system used, the permissible voltage across the terminals of power generating sets of electrical power sources with frequencies of 50 and 60 Hz shall be found under 4.1. Additional requirements for apparatus designed for a voltage in excess of 1000 V shall be found in Section 18.

4.2.2 Permissible voltage across the terminals of sources of electrical power and direct current sources shall not exceed the values below:

500 V for power systems;

250 V for lighting and heating systems, and socket outlets.

4.2.3 Permissible voltage across the terminals of alternating-current consumers shall not exceed the values specified in Table 4.2.3.

Table 4.2.3

Nos	Consumers	Permissible voltage, V
1	Permanently installed power consumers, cooking and heating appliances permanently installed in spaces other than those specified in item 2	1000
2	Portable power consumers supplied from socket outlets fixed in position when used, heaters in cabins and passenger accommodation (refer to 15.2.5)	500
3	Lighting, signalling and internal communication, socket outlets for portable consumers with double or reinforced insulation or isolated electrically by isolating transformer	250
4	Socket outlets fitted in locations and spaces with increased humidity, and in extra humid spaces, and intended for supply of consumers having no double or reinforced insulation and not isolated electrically	50

4.2.4 Permissible voltage across the terminals of direct-current consumers shall not exceed the values specified in Table 4.2.4.

4.3 POWER SUPPLY OF ESSENTIAL SERVICES

4.3.1 The following services shall be supplied by separate feeders from the main switchboard busbars:

.1 steering gear electric drives (refer also to 5.5.2);

Table 4.2.4

Nos	Consumers	Permissible voltage, V
1	Permanently installed power consumers	500
2	Cooking, heating, etc. appliances	250
3	Lighting, socket outlets ¹	250

¹In spaces with increased humidity and extra humid spaces, notices shall be provided at socket outlets with voltage exceeding the overrating voltage to notify of the use of consumers with double or reinforced insulation or those electrically isolated from overrating voltage.

- .2 anchor gear electric drives (refer also to 4.3.3);
- .3 fire pump electric drives;
- .4 bilge pump electric drives;
- .5 electric drives of sprinkler system compressors and pumps equipment to ensure operating of foam generators of high expansion foam system;
- .6 gyrocompass;
- .7 refrigerating plant switchboard for cargo holds;
- .8 electric drives of exciter sets of propulsion plant;
- .9 section main-lighting switchboards;
- .10 radio equipment switchboard;
- .11 switchboard of navigational equipment;
- .12 navigation light switchboard;
- .13 section switchboards and distribution gear for supplying other essential services combined on the principle of uniformity of their functions;
- .14 switchboards of integrated bridge control console (refer also to 4.5);
- .15 switchboard of automatic fire detection system;
- .16 electric drives of auxiliaries ensuring the operation of main machinery;
- .17 switchboards of electric drives for cargo, mooring, boat and other gears, ventilation and heating appliances;
- .18 control devices of controllable pitch propeller;
- .19 charging facilities of starter accumulator batteries and batteries supplying essential consumers;
- .20 switchboards of electric drives for closure of watertight doors and devices holding fire doors in open position and closure of watertight and fire doors;
- .21 switchboard of refrigerating plant for the low pressure carbon dioxide extinguishing system;
- .22 lighting switchboards for hangars and helicopter deck illumination;
- .23 other services not listed above as required by the Register.

It is permitted to supply services indicated in 4.3.1.4, 4.3.1.10 to 4.3.1.12, 4.3.1.15, 4.3.1.16, 4.3.1.18 to 4.3.1.20, from switchgear indicated in 4.3.1.13 or 4.3.1.14 by separate out-going feeders

provided with adequate switching and protective devices.

4.3.2 In case one-purpose machinery with electric drives indicated in 4.3.1 is installed in double or greater number, except for specified in 4.3.1.1, 4.3.1.5 and 4.3.1.8 at least one of these drives shall be energized by a separate feeder from the main switchboard. Electric drives of the rest of such machinery are allowed to be supplied from section switchboards or special distribution devices intended for supply of essential services.

When the collecting busbars in the main switchboard are subdivided into sections having intersectional disconnecting devices, the electric drives, section switchboards, special distribution devices or boards installed in double or greater number or supplied by two feeders shall be connected to different sections of the main switchboard.

4.3.3 In cargo ships of restricted areas of navigation **R2**, **R2-RSN**, **R2-RSN(4,5)**, **R3-RSN** and **R3**, and in particular cases in ships of unrestricted service and ships of restricted area of navigation **R1**, the supply feeder of anchor gear may be connected to the distribution board of cargo winches or to another distribution board, on special approval of the Register, provided the boards are supplied directly from the main distribution board and adequate protection is available.

4.3.4 Final sub-circuits having a current rating in excess of 16 A shall supply not more than one consumer.

4.4 POWER SUPPLY OF ELECTRICAL (ELECTRONIC) AUTOMATION SYSTEMS

4.4.1 Power supply of electrical (electronic) automation systems shall satisfy the requirements of Part XV "Automation".

4.4.2 Power supply of automation devices necessary for starting and operating the emergency diesel generator shall be taken from a starter battery or another independent accumulator battery installed in the emergency diesel generator space.

4.5 POWER SUPPLY TO INTEGRATED BRIDGE CONTROL CONSOLE

4.5.1 When locating in the integrated bridge control console the electrical equipment, navigational equipment, radio equipment, electrical automatic and remote-control equipment for the main and auxiliary machinery, such equipment shall be supplied by separate feeders as required in the present Chapter and other parts of the Rules.

It is allowed to feed the equipment specially listed in 4.3.1 from the switchboards of the integrated bridge control console, provided the requirements of 4.5.2 to 4.5.6 are met (refer to 9.4.3 as well).

4.5.2 The switchboards of the integrated bridge control console shall be fed from the main switchboard directly or through the transformers by two independent feeders connected to different sections of the main switchboard busbars, where busbars are subdivided.

When the emergency generator is provided on board the ship, the switchboards of the integrated bridge control console shall be supplied by one feeder from the main switchboard and by one feeder from the emergency switchboard.

4.5.3 In addition, the switchboards of the integrated bridge control console shall be independently supplied by a separate feeder from other source or sources of power, if necessary, basing on the requirements for the equipment fed from these switchboards.

4.5.4 The switchboard shall be provided with a change-over switch for feeders specified in 4.5.2.

If an automatic change-over switch is used, manual switching of feeders shall be also ensured. In this case, provision shall be made for necessary interlocking.

4.5.5 Each consumer specially listed in 4.3.1 fed from the switchboards of the integrated bridge control console shall be supplied by a separate feeder (refer also to 9.4.3).

4.5.6 In the integrated bridge, control console a light signalling device indicating the presence of voltage shall be fitted.

4.6 SWITCHBOARD AND SWITCHGEAR

4.6.1 Switchboard design and construction.

4.6.1.1 Frames, front panels and enclosures of main, emergency, section and distribution switchboards shall be constructed of metal or some other durable non-combustible material.

Where the aggregate capacity of generators intended for parallel operation exceeds 100 kW, barriers shall be installed between the generator sections and adjacent sections for protection against the effects of arcs.

4.6.1.2 Switchboards shall be of rigid construction capable of withstanding the mechanical stresses liable to occur under service conditions or as a result of short circuits.

4.6.1.3 Switchboards shall at least be protected from drip. This protection is not required if the switchboards shall be located in spaces where the conditions are such that no vertically falling drops of liquid can get into the switchboard (refer also to 4.6.6.2).

4.6.1.4 Switchboards intended to be installed in places accessible to unauthorized persons shall be provided with doors to be opened by means of a special key, the same for all the switchboards in the ship.

4.6.1.5 The design of switchboard doors shall be such that with the doors opened access is assured to all parts which require maintenance, and the live parts located on the doors shall be protected against inadvertent touching.

Opening panels and doors, which are used for mounting electrical control gear and measuring instruments, shall be securely earthed with at least one flexible connection.

4.6.1.6 Handrails shall be fitted to main, emergency and section switchboards and to control panels on their front sides. Switchboards accessible from the rear shall be provided with horizontal handrails fitted at the back.

The materials, which may be used for manufacture of handrails, are insulating material, wood or earthed metal pipes with insulating covering.

4.6.1.7 The generator panels of main switchboards shall be illuminated with lighting fixtures supplied on the generator side before the circuit breaker of the generator or not less than from two different busbar systems in case these systems are provided according to 3.5.6. When no such systems are provided, lighting fixtures may be supplied from the emergency switchboard.

4.6.1.8 The lighting of the front side of switchboard panels shall not interfere with instrument observation or produce a blinding effect.

4.6.1.9 The design of switchboards and control consoles not accessible from the rear shall be such that the access is ensured to all parts requiring maintenance.

Arrangements shall be provided for doors of switchboards to fix them in the open position.

Withdrawable blocks and instruments shall be fitted with devices to prevent their fall-out in the withdrawn position.

4.6.1.10 Each distribution device designed for voltage over the safe, with switchgear and protective devices and without a voltmeter, shall be furnished with a pilot lamp, which indicates the presence of voltage on busbars.

4.6.2 Busbars and uninsulated conductors.

4.6.2.1 The maximum permissible temperature for switchboard busbars and uninsulated conductors at the rated load and short-circuit current or at the permissible one-second short-circuit load for copper busbars shall be determined according to national standards.

4.6.2.2 Equalizer busbars shall be designed for at least 50 % of the rated current of the largest generator connected to the main switchboard.

4.6.2.3 Where the busbar is in contact with or close to insulated parts, its heat effects shall not cause

under operating or short-circuit conditions a temperature rise in excess of that allowable for a given insulating material.

4.6.2.4 Busbars and uninsulated conductors in switchboards shall have adequate electrodynamic and thermal strength during short-circuit currents occurring at relevant points in the circuit.

Such electrodynamic loads as occur in busbars and uninsulated conductors due to short circuit shall be as specified in the relevant national standards.

4.6.2.5 Insulators and other parts designed to support busbars and uninsulated conductors shall be capable of sustaining the loads due to short circuits.

4.6.2.6 The natural frequency of copper tier busbars shall be outside the ranges of 40 to 60 Hz and 90 to 110 Hz for rated frequency of 50 Hz, 50 to 70 Hz and 110 to 130 Hz for rated frequency of 60 Hz.

4.6.2.7 Busbars and uninsulated conductors of different polarity shall be marked with the following distinguishing colours:

- .1 red for positive pole;
- .2 blue for negative pole;
- .3 black or green and yellow for earth connections;
- .4 light blue — for middle wire.

The equalizer connection shall be marked with white transverse bands in addition to the appropriate colour as given above.

4.6.2.8 Busbars and uninsulated conductors of different phases shall be marked with the following distinguishing colours:

- .1 yellow for phase 1;
- .2 green for phase 2;
- .3 violet for phase 3;
- .4 light blue for neutral wire;
- .5 green and yellow for earth connections.

4.6.2.9 Busbars shall be connected so as to prevent corrosion in way of connections.

4.6.3 Calculation of short-circuit currents and selection of electrical switch apparatus.

4.6.3.1 Short-circuit current shall be calculated on the basis of the standards or calculation methods approved by the Register.

4.6.3.2 In calculations of the maximum and minimum short-circuit currents a source of short-circuit current shall contain all generators including synchronous condensers, which may be connected in parallel, and all electric motors running simultaneously and able to produce current contribution to the short-circuit point¹. Calculation is carried out at three-phase "metal" short-circuit.

Calculation of short-circuit currents shall be performed for all electric circuits where electrical equipment is installed which was selected and

monitored with regard to permissible short-circuit current supplied directly from the busbars of the main switchboard, including busbars of switchboards for their testing for electrodynamic withstandability and heating while passing of short-circuit current.

These calculations shall be made at least for the following points:

- on the generator side on the automatic circuit breaker terminals;
- on the main switchboard busbars;
- on the emergency switchboard busbars;
- on the terminals of electric power consumers and busbars of the switchboards supplied directly from the main switchboard.

For evaluation of protective sensitiveness the calculation shall be made both of maximum and minimum short-circuit currents at the terminals of power consumers.

Calculation of short-circuit current in the circuit from the generator terminals up to the main switchboard busbars is made at the outputs of the generator automatic circuit breaker. Short-circuit current at the generator terminals is calculated with the availability of inner short-circuit protection of stator winding (for example, differential protection).

The results of short-circuit current calculation shall contain the list of all the electrical switch apparatus fitted and their parameters, as well as the maximum and minimum prospective short-circuit current at the points of their installation.

4.6.4 Electric switch apparatus and instrumentation.

4.6.4.1 Apparatus, measuring and indicating instruments used in connection with generators and other large essential installations shall be fitted on the switchboards associated with the appropriate generators and installations.

This requirement may be dispensed with in the case of generators where there is a central control console with switch gear and measurements for several generators.

4.6.4.2 One ammeter and one voltmeter shall be provided for each direct-current generator on the main and emergency switchboards.

4.6.4.3 The following instruments shall be provided for each alternating current generator on the main switchboard and for emergency generator on the emergency switchboard:

- .1 an ammeter with a selector switch for current measurements in each phase;
- .2 a voltmeter with a selector switch for measuring phase or line voltages;
- .3 a frequency indicator (use of one double frequency indicator is permissible for generators operating in parallel with change-over to each generator);
- .4 a wattmeter (for output upwards of 50 kVA);
- .5 other instruments as required.

¹Electrical motors supplied from semiconductor converters do not produce current contribution.

4.6.4.4 In ships having a low-power electrical installation, in which the generators are not expected to operate in parallel, one set of instruments as stipulated by 4.6.4.2 and 4.6.4.3 may be installed at the main and emergency switchboards, which would ensure a possibility of taking measurements at each generator installed.

4.6.4.5 Ammeters shall be installed in the circuits of essential consumers rated at 20 A and over. These ammeters may be installed on the main switchboard or at the control stations.

It is allowed to install ammeters with selector switches but not more than for six consumers.

4.6.4.6 In the main switchboard the feeder energized from the external power source shall be provided with:

- .1 switchgear and protective devices;
- .2 a voltmeter or a pilot lamp;
- .3 means of protection against phase breaking.

4.6.4.7 A change-over arrangement or a separate device for each network of isolated systems for measuring and indicating insulation resistance shall be installed on the main and emergency switchboards.

In any case, the hull leakage current due to the operation of the measuring device shall not exceed 30 mA.

Provision shall be made for audible and visual alarms to warn of inadmissible decrease in the insulation resistance.

In ships with unattended machinery spaces this signalling shall be also provided at the ship's main machinery control room.

4.6.4.8 Measuring instruments shall have scales with a margin of divisions in excess of the rated values of quantities to be measured.

The upper scale limits of the instruments used shall not be less than:

- .1 for voltmeters — 120 % of the rated voltage;
- .2 for ammeters associated with generators not operating in parallel and with current consumers — 130 per cent of the rated current;
- .3 for ammeters associated with parallel-operating generators — 130 % of the rated current for load-current scale and 15 % of the rated current for reverse-current scale (the latter refers only to direct-current generators);
- .4 for wattmeters associated with generators not operating in parallel — 130 % of the rated output;
- .5 for wattmeters associated with generators operating in parallel — 130 % for power scale and 15 per cent for reverse power scale;
- .6 for frequency indicator — ± 10 % of the rated frequency.

4.6.4.9 Voltage, current and power ratings of electric power plant and generators shall be clearly indicated on the scales of electrical measuring instruments.

4.6.4.10 Wherever possible, switchgear shall be installed and connected to busbars in such a way that none of the movable elements and protective or control devices associated with switchgear are energized in the open position.

4.6.4.11 When switches with fuses are installed in outgoing circuits of switchboards, the fuses shall be positioned between the busbar and the switch.

4.6.4.12 Where switchboards are installed on a foundation at the floor level, the fuses shall be located not lower than 150 mm and not higher than 1800 mm from the floor level.

Live open parts of switchboards shall be located at a height of not less than 150 mm above the floor level.

4.6.4.13 Fuses shall be so installed in switchboards that they are easily accessible and the fuse link replacement is not dangerous for the operating personnel.

4.6.4.14 The fuses protecting the poles or phases of the same circuit shall be installed in a row, horizontally or vertically depending on the fuse design. The fuses in an a.c. circuit shall be positioned to follow the sequence of phases from left to right or from top to bottom.

In a d.c. circuit the positive-pole fuse shall be on the left, at top, or closer to reach.

4.6.4.15 The manual actuators of voltage regulators installed in main or emergency switchboards shall be positioned close to the measuring instruments associated with the respective generators.

4.6.4.16 The ammeters of direct current compound generators intended for operation in parallel shall be included in the hole circuit not connected to the common wire.

4.6.4.17 For connecting portable and semi-portable instruments, flexible-stranded conductors shall be used.

4.6.4.18 Switch electrical apparatus controls, panels and outgoing circuits on the switchboards shall have their designations marked. The apparatus switching positions shall be also indicated. Besides, markings shall be provided to indicate the rated currents of the installed safety devices and switches, settings of circuit breakers and electrothermal trips.

4.6.4.19 Each outgoing circuit in a switchboard shall be provided with an appropriate circuit breaker to disconnect all poles and phases. Switches or circuit breakers may be dispensed with in lighting branch boxes provided with a common switch and also in the circuits of instruments inter-locking devices, alarms and local lighting of switchboards protected by fuses.

4.6.5 Light signals.

4.6.5.1 Light signals shall be of the colour specified in Table 4.6.5.1.

Table 4.6.5.1

Colour	General meaning	Type of signal	Condition of device
Red	Danger	Blinking Permanent	Alarm in dangerous conditions where immediate action is necessary Alarm in dangerous conditions, detected, but not yet rectified
Yellow	Attention	Blinking Permanent	Abnormal conditions where immediate action is not required Intermediate condition between abnormality and safety Abnormal condition already detected, but not yet rectified
Green	Safety	Blinking Permanent	Standby machinery is put into operation Rated conditions of running and operation
Blue	Information	Permanent	Machinery and gear are ready to be started Voltage in mains. Everything is in order
White	General information	Permanent	Signals switched on when necessary Notations relating to automatic control conditions Other auxiliary signals

4.6.5.2 The use of letters as light signals is acceptable on condition that letters clearly identify the condition of device.

4.6.6 Arrangement of distribution gear.

4.6.6.1 The switchboards shall be placed in locations where the possible concentration of gases, water vapours, dust and acid evaporations is eliminated.

4.6.6.2 If the switchboard having protective enclosure of IP10 type and below is located in a special space, cabinet or recess, then such spaces shall be made of non-combustible material or shall have a lining of such material.

4.6.6.3 Arrangement of pipelines and tanks near the switchboards shall conform to the requirements of 5.5, Part VIII "Systems and Piping".

4.6.6.4 The navigation lights switchboard shall be located in the wheelhouse where it is readily accessible and visible to the personnel on watch.

4.6.6.5 The main switchboard and generating sets shall be positioned in close proximity to each other, in the same engine room and within the boundaries of the same "A-60" class vertical and horizontal fire-resistant constructions. The enclosure situated within the main boundaries of machinery space, provided for the main machinery control room where the main switchboard is positioned, is not considered as separating the main switchboard from the generating sets.

Where essential services for steering and propulsion of ship are supplied from section switchboards these switchboards and any transformers, converters

and similar equipment forming the essential part of the system supplying these services shall be also positioned in the same space as generating sets.

4.6.7 Access to switchboards.

4.6.7.1 In front of the switchboard, a passageway shall be provided not less than 800 mm wide for switchboards up to 3 m long, and not less than 1000 mm wide for switchboards 3 m long and over.

In ships of less than 500 gross tonnage, the width of the passageway may be reduced to 600 mm.

4.6.7.2 Behind the free standing switchboards, it is necessary to provide a passageway not less than 600 mm wide for switch boards up to 3 m in length and not less than 800 mm wide, for longer switchboards.

Between the free standing switchboards with open live parts located in special electrical spaces a passageway shall not be less than 1000 mm wide.

4.6.7.3 The space behind the free standing switchboards with open live parts shall be enclosed and fitted with doors in accordance with 2.8.1.

4.6.7.4 For switchboards more than 3 m in length mentioned in 4.6.7.3 at least two doors shall be provided leading from the space where the switchboard is installed to the space behind the switchboard. These doors shall be as widely spaced as possible.

It is allowed that one of these doors shall lead to the adjacent space having at least another exit.

4.6.7.5 Passageways specified in 4.6.7.1 and 4.6.7.2 are measured from the most protruding parts of apparatus and structure of the switchboard to the protruding parts of equipment or hull structures.

5 ELECTRIC DRIVES FOR SHIPBOARD MECHANISMS AND EQUIPMENT

5.1 GENERAL

5.1.1 The control stations of the drives shall meet the relevant requirements of Part VII "Machinery Installations", while the power supply of electrical (electronic) automation systems shall meet the requirements specified in Part XV "Automation".

5.1.2 Electrically-driven mechanisms shall be provided with light signals to indicate switching-on of the electric drive.

5.1.3 Equipment provided with automatic, remote and local control shall be so designed that the automatic control is switched off as well as the remote control when the change-over to the local control occurs. The local control shall be independent both of the automatic and remote control.

5.2 INTERLOCKING OF MACHINERY OPERATION

5.2.1 The machinery provided with electric and manual drives shall be fitted with an interlocking device that will prevent simultaneous operation of the drives.

5.2.2 If the machinery is required to operate in a certain sequence, appropriate interlocking devices shall be used.

5.2.3 A device may be installed that will switch off the interlocking on condition that this device is protected from switching off the interlocking inadvertently. Informative inscription shall be placed in close proximity to this device that will indicate its application and forbid its use by unauthorized personnel.

Such a device is not permitted for machinery specified in 5.2.1.

5.2.4 Starting of the machinery, which electric motors or switchgear require additional ventilation in normal operation, shall be possible only with ventilation in action.

5.3 SAFETY ISOLATION DEVICES

5.3.1 Control systems of mechanisms, which operation under certain conditions may endanger human or ships safety, shall be provided with push-buttons or other safety isolation devices that will

ensure disconnection of the electric drive from the power supply.

These push-buttons and/or other safety isolation devices shall be suitably protected against inadvertent actuation.

5.3.2 Push-buttons or other safety isolation devices shall be located near the control stations or in other places with a view to ensure safety of operation.

5.3.3 Electric drives of arrangements and machinery which require restriction of motion to prevent damage or break-down shall be provided with terminal switches to ensure reliable isolation of the electric motor.

5.4 SWITCHGEAR AND CONTROL GEAR

5.4.1 The switchgear in the circuits of electric drives, which in itself does not provide for short-circuit protection shall withstand the short-circuit current that may flow at the point of its installation during the time required for operation of a special protection device.

5.4.2 Starting of the engine shall be possible only from the zero position of the control gear.

5.4.3 A discharge protection device shall be provided for the control gear that permits isolation of the shunt-field windings.

5.4.4 For directly started alternating-current electric motors, the requirements of 3.1.2.2 and 16.8.3.3 shall be taken into consideration.

5.4.5 For each electric motor rated at 0,5 kW and more and its control gear, provision shall be made for fitting a device to isolate the power supply. If the control gear is mounted on the main switchboard or on any other switchboard in the same compartment and its visibility is ensured from the place of installation of the electric motor, then for this purpose it is permitted to use a switch mounted on the switchboard.

If the requirements in respect of location of machine control gear stated above are not met, the following shall be provided:

.1 a device interlocking the switch on the switchboard in the "off" position; or

.2 an additional disconnecting switch near the electric motor; or

.3 fuses in each pole or phase of the control gear arranged in such a manner that they could be readily removed or replaced by the personnel.

5.5 ELECTRIC DRIVES AND CONTROL OF STEERING GEAR

5.5.1 In addition to the requirements of 6.2, Part IX "Machinery" and 2.9, Part III "Equipment, Arrangements and Outfit", steering gear shall comply with the requirements of the present Part of the Rules.

5.5.2 Main electric or electro-hydraulic steering gear comprising one or more power units shall be supplied by two separate feeders laid directly from the main switchboard in two different runs (refer also to 16.8.4.12). One of these feeders may be supplied through the emergency switchboard.

When the collecting busbars in the main switchboard are subdivided, each feeder shall be supplied from different sections (refer also to 4.3.2).

In case the auxiliary electric or electro-hydraulic steering gear is provided according to 2.9, Part III "Equipment, Arrangements and Outfit", it may be supplied from the feeders of the main electric steering gear.

5.5.3 Each feeder shall be selected so as to supply all the electric motors, which are normally connected thereto and operate simultaneously.

5.5.4 If a change-over arrangement is provided to supply any electric motor or a combination of motors from one or the other feeders, such feeders shall be designed for operation under the most severe loads, and the change-over arrangement shall be installed in the steering gear compartment.

5.5.5 In case a steering gear power unit becomes inoperative, another unit required by 2.9.4, Part III "Equipment, Arrangements and Outfit" shall be actuated manually from the bridge control station. Provision may be made for an additional automatic actuation of the power unit.

5.5.6 In every ship provided with steering gear according to 2.9.6, Part III "Equipment, Arrangements and Outfit" in the event of failure of the main source of electric power of the steering gear power unit provision shall be made for automatic connection within 45 s to the emergency source of electrical power or an other independent source located in the steering gear compartment and intended only for this purpose.

For ships of 10000 gross tonnage and over the power of this source shall be sufficient for continuous supply of the steering gear, associated control system and rudder angle indicators within at least 30 min and for all other ships, within at least 10 min.

5.5.7 The operating conditions for the electric motors of the drives for the active means of the ship's steering shall conform to the conditions prescribed for the entire gear, but the motors shall at least satisfy the short-term operating conditions during not less than 30 min.

5.5.8 The electric or electrohydraulic drive of a steering gear shall ensure:

.1 putting the rudder from hard over to hard over within the time and angle stated in 6.2.2, Part IX "Machinery";

.2 putting the rudder continuously from hard over to hard over during 30 min for each set at the maximum service speed ahead corresponding to the draught at which the rudder is fully immersed (refer also to 2.9.2 and 2.9.3, Part III "Equipment, Arrangements and Outfit");

.3 continuous operation during one hour at the maximum service speed ahead with putting the rudder over through an angle so as to ensure 350 puttings over per hour;

.4 possible stalling of the electric motor in "on" position for one minute from hot state (only for rudders fitted with the direct electric drive);

.5 sufficient strength of electric drive in the presence of mechanical forces arising at maximum speed astern.

It is recommended that a possibility shall be provided for putting the rudder over at the average speed astern.

5.5.9 Starting and stopping of the steering gear electric motors, other than electric motors of rudders with direct electric drive, shall be effected from the steering room and from the wheelhouse.

5.5.10 The starting devices shall ensure automatic restarting of electric motors as soon as the voltage is restored after a discontinuity in power supply.

5.5.11 Visual and audible alarm shall be initiated on the navigation bridge in case of:

.1 power supply failure of each power unit, the control system, as well as the earth faults;

.2 short circuit, broken connections, earth faults in command and feedback loops;

.3 data communication errors, computer hardware and software failures (if programmable electronic systems are used);

.4 low oil level in any tank of the hydraulic system;

.5 hydraulic locking;

.6 critical deviations between rudder order and response unless rudder's actual position reaching the set value position within acceptable time limits for feedback control systems (eg, for the follow-up control system and autopilot). The alarm may be actuated with mechanic, hydraulic or electric failures.

Besides, means shall be provided to indicate operation of electric motors of the steering gear power units.

5.5.12 Failures, including those specified in 5.5.11, that can cause uncontrolled movement of the rudder blade shall be clearly identified. In case of the failures identification the rudder blade shall be fixed in the current position.

5.5.13 The following visual and audible alarm shall be provided at the main machinery control room:

- .1 loss of voltage, phase break-off;
- .2 power supply circuit overload of each power unit;
- .3 low oil level in any tank of the hydraulic system.

Besides, means shall be provided to indicate operation of electric motors of the steering gear power units.

5.5.14 The steering gear control systems specified in 2.9.13 and 2.9.14, Part III "Equipment, Arrangements and Outfit" shall be supplied by separate feeders laid in different runs from the power circuits of the steering gear in the steering gear compartment or directly from the busbars of the switchboard serving these power circuits.

5.5.15 In the steering gear compartment means shall be provided for disconnecting any bridge control system from the steering gear it serves.

5.5.16 Each remote control system specified in 2.9.13 and 2.9.14, Part III "Equipment, Arrangements and Outfit" shall have its own independent circuit, including all electrical components, for transmission of orders to the steering gear actuator and shall be so arranged that a mechanical or electrical failure in one of them will not render the other one inoperative. Wires, terminals and the components for duplicated steering gear control systems installed in units, control boxes, switchboards or bridge consoles, as well as circuits of common switching units of control systems, shall be separated as far as practicable or separated by means of a fire retardant plate.

5.5.17 In the case of double follow-up control, the amplifiers shall be electrically and mechanically separated. In the case of non-follow-up control and follow-up control, it shall be ensured that the follow-up amplifiers are protected selectively. Therewith, selectivity of protection devices actuation shall be ensured.

5.5.18 Where additional control systems are provided, their control circuits shall be designed for all-pole disconnection.

5.5.19 Feed-back units and limit switches for the steering gear control systems shall be separated electrically and mechanically connected to the rudder stock or actuator separately.

5.5.20 Any of the most probable failures (loss of power or failure in feedback control systems) shall not result in the complete loss of steering capability.

5.5.21 The direction of rotation of the rudder wheel or the direction of motion of the control gear handle shall agree with the direction of putting the rudder over.

In the push-button control system, the push-buttons shall be arranged in such a manner that the

switching on of the push-button located to the right causes the rudder blade to move rightward, while the button to the left its motion leftward.

5.6 ELECTRIC DRIVES OF ANCHOR AND MOORING MACHINERY

5.6.1 In addition to the requirements of 6.3 and 6.4, Part IX "Machinery", the drives of windlasses, anchor and mooring capstans and mooring winches shall comply with this Part of the Rules.

5.6.2 Electric drives of anchor and mooring machinery shall ensure possible stalling. Duration of stalling shall be limited by the activating time of overload protection or winding temperature protection, but not exceeding 30 s for anchor machinery and 15 s for mooring machinery.

5.6.3 In anchor and mooring capstans and mooring winches at the speed steps intended only for mooring operations provision shall be made for overload protection of the electric motor.

5.6.4 The supply of electric drives of anchor capstans shall be effected in conformity with 4.3.1 and 4.3.3.

5.7 ELECTRIC DRIVES OF PUMPS

5.7.1 The electric motors of fuel and oil transfer pumps and separators as well as of organic coolant circulation pumps shall be provided with remote disconnecting switches located outside the space wherein these pumps are placed and outside the machinery casings, but in close vicinity of the exits from these spaces.

5.7.2 The electric motors of the pumps transferring the liquids overboard through the drain holes above the lightest waterline at locations where lifeboats or liferafts are lowered shall be provided with disconnecting switches located near the control stations of the driving machinery for lowering the relevant boats or rafts.

5.7.3 The electric motors of emergency fire pumps and submersible bilge pumps shall be provided with remote starting devices located above the bulkhead deck (refer to 3.2.3.9, Part VI "Fire Protection").

A remote starting device shall be provided with a light signal indicating the "on" condition of the electric drive.

5.7.4 Disconnecting switches of electric drives specified in 5.7.1 shall be located in conspicuous positions covered with glass and provided with explanatory inscriptions. The disconnecting switches shall de-energize feeders of those electric drives.

5.7.5 Local starting of fire and bilge pumps shall be possible even in case of failure of their remote control circuits, including protection equipment.

5.7.6 The electric motors of oily and sewage water transfer and discharge pumps shall be provided with remote cut-off arrangements located in the vicinity of discharge manifolds, provided no telephone or radio communication is available between the discharge observation position and discharge control position.

5.8 ELECTRIC DRIVES OF FANS

5.8.1 The electric motors of ventilation fans in machinery spaces shall be provided with at least two disconnecting switches, one of which shall be located outside these spaces and their casings, but in close vicinity of the exits from these spaces. It is recommended that these disconnecting switches be positioned together with similar switches referred to in 5.7.1.

5.8.2 The electric motors of ventilation fans of cargo holds and galley fans shall be provided with disconnecting switches at locations readily accessible from the main deck, but outside the machinery casings.

Electric motors of exhaust ventilation from galley ranges shall be provided with a disconnecting switch located inside the galley, regardless of the number of disconnecting switches.

5.8.3 The electric motors for general shipboard ventilation shall have at least two switches for remote disconnection of the motors, one of the switches being fitted in the wheelhouse and the other accessible from the open deck.

For ships with electrical installation of low power (other than passenger ships) it is permitted to use one disconnecting switch located in the wheelhouse or in a position readily accessible from the main deck.

5.8.4 The electric motors of fans in the spaces protected by a smothering system shall be provided with a disconnecting switch operating automatically when fire extinguishing medium is discharged into the space. When such spaces are fitted with fire closing appliances that automatically block air access therein, the manual switching off the fans may be permitted; therewith, the disconnecting switches shall be located outside the above spaces.

5.8.5 The disconnecting switches of the electric motors of fans listed in 5.8.1 to 5.8.3 shall be so grouped on board the ship that all these electric motors could be stopped from not more than three positions. The disconnecting switches shall de-energize feeders of those electric motors of fans.

5.9 ELECTRIC DRIVES OF BOAT WINCHES

5.9.1 The electric drives of boat winches shall comply with the requirements of 6.20, Part II "Life-Saving Appliances" of the Rules for the Equipment of Sea-Going Ships.

5.9.2 The winch electric drive controls shall be provided with self-return to the "stop" position.

5.9.3 A switch in power circuit of the electric motor shall be installed near the boat winch control station.

5.10 ELECTRIC DRIVES OF WATERTIGHT AND EIRE DOORS

5.10.1 The electric drives of watertight doors shall meet the requirements of 7.12, Part III "Equipment, Arrangements and Outfit".

5.10.2 Power supply of electric drives and indicators of position and closure of the watertight doors shall be taken from the main, emergency and emergency intermediate sources of electrical power in accordance with 4.3.1, 9.3 and 19.1.2.

5.10.3 As far as practicable, electrical equipment and components for watertight doors shall be situated above the bulkhead deck and outside dangerous areas and spaces.

5.10.4 Suitable protection from water penetration shall be provided for the enclosures of the following electrical equipment positioned perforce below the bulkhead deck:

- .1 electric motors and control equipment circuits related thereto — IPX7;
- .2 door position indicator sensors and circuit elements related thereto — IPX8;
- .3 door movement audible alarm elements — IPX6.

5.10.5 Electric power, control, indication and alarm circuits shall be protected against fault in such a way that a failure in one door circuit will not cause a failure in any other door circuit. Short circuits or other faults in the alarm or indicator circuits of a door shall not result in a damage in the electric power and control circuits. Arrangements shall be such that leakage of water into the electrical equipment located below the bulkhead deck will not cause the door to open.

5.10.6 A single failure in the power operating or control circuits of a sliding watertight door shall not result in a closed door opening. Availability of the power supply shall be continuously monitored in the immediate vicinity of each of the motors required by 7.12.5.7, Part III "Equipment, Arrangements, and

Outfit". Loss of power supply in the power operating and control circuits shall activate an audible and visual alarm in the main machinery control room and at the navigation bridge.

5.10.7 The electric drives of devices for holding the fire doors in the open position (refer to 2.1.3.4, Part VI "Fire Protection") shall:

.1 be supplied from the main and emergency sources of electrical power;

.2 be remotely controlled from the wheelhouse for closing the doors individually, in groups or all doors simultaneously;

.3 automatically close all the doors simultaneously in case of the supply voltage loss;

.4 be so designed that any damage in the mechanism of closing any door could not render inoperative the systems of supply and operation of other doors.

5.11 ELECTRIC DRIVES FOR OIL BURNER UNITS OF BOILERS AND INCINERATORS

5.11.1 Electric drives for oil burner units of boilers and incinerators shall be provided with remote shut off devices located outside the spaces where they are installed (refer also to 5.3.8, Part X

"Boilers, Heat Exchangers and Pressure Vessels" and 4.3.6, 4.10.3.4 and 6.2.3, Part XV "Automation").

5.11.2 Where the spaces in which the incinerators and boilers are installed are protected by aerosol fire-extinguishing system, the electric drives for oil burner units of boilers and incinerators shall be automatically shut off when the said system is activated.

5.12 ELECTRIC DRIVES OF DEWATERING ARRANGEMENTS OF FORWARD SPACES OF BULK CARRIERS

5.12.1 In addition to the requirements of 7.9.2 and 7.9.3, Part VIII "Systems and Piping", electric drives of dewatering arrangements of forward spaces of bulk carriers shall meet the requirements of the present Part.

5.12.2 Positive indication shall be provided at the navigation bridge or other station complying with the requirements of 7.9.2, Part VIII "Systems and Piping" to show that the valve is fully open or closed.

5.12.3 The enclosures of electrical equipment for the dewatering system installed in any of the forward dry spaces shall provide protection to not lower than IPX8 standard for a water head equal to the height of the space in which the electrical equipment is installed for a time duration of at least 24 h.

6 LIGHTING

6.1 GENERAL

6.1.1 In all ship's spaces, places and zones where the illumination is essential for safety of navigation, control of machinery and gear, habitability and evacuation of passengers and crew, pilot embarkation and disembarkation stationary main lighting fixtures shall be provided, which are supplied from the main source of electrical power.

The list of spaces, places and zones where the emergency lighting fixtures shall be installed in addition to the main ones is given in 9.3.1.1 and 19.1.2.1.1.

6.1.2 Lighting fixtures installed in spaces and zones where mechanical damage is possible to the glass hoods shall be provided with protection gratings.

6.1.3 Lighting fixtures shall be installed in such a manner as to prevent heating of cables and adjacent materials up to a temperature exceeding the permissible level.

6.1.4 In spaces or spaces illuminated with luminescent lamps where visible rotating parts of machinery are located, all measures shall be taken to prevent stroboscopic effect.

6.1.5 External-illumination lighting fixtures shall be so installed that no light interference with ship's navigation could occur.

6.1.6 In spaces and zones illuminated with discharge lamps, which do not ensure continuity of burning at voltage variations according to 2.1.3, provision shall be also made for lighting fixtures with incandescent lamps.

6.1.7 Battery and other dangerous compartments shall be illuminated with lighting fixtures located in adjacent safe spaces through gastight windows, or with safe-type lighting fixtures located inside the compartment (refer also to 2.9).

6.2 POWER SUPPLY OF MAIN LIGHTING ELECTRIC CIRCUITS

6.2.1 The switchboards of the main lighting shall be supplied by separate feeders. The main lighting switchboards may supply the electric drives of non-essential services rated up to 0,25 kW and individual cabin heaters rated up to 10 A.

6.2.2 The protective devices of final lighting circuits shall be set to operate at a current rating not exceeding 16 A, the total load current of the consumers connected shall not exceed 80 % of the current setting of the protective device.

The number of lighting fixtures supplied by final lighting circuits shall not exceed that specified in Table 6.2.2. Cabin fans and other appliances may be supplied by final lighting circuits.

Table 6.2.2

Voltage, V	Maximum number of lighting fixtures
Up to 50	10
51 to 120	14
121 to 250	24

6.2.3 Lighting of corridors, machinery spaces, propeller shaft tunnels, boiler water-level indicators shall be supplied by not less than two independent feeders, with the lighting fixtures arranged in such a manner that, even in case of failure of either feeder, as uniform lighting as possible is ensured. These feeders shall be supplied from different distribution boards, which, in case of application of the lighting subdivided busbars in the main switchboard, shall be supplied from different busbar sections. One of the feeders may be that supplying from the emergency switchboard.

For cargo ships with the electrical installation of low power it is allowed that lighting of the above spaces, except for machinery spaces, be supplied by one feeder from the distribution board or from the main switchboard directly.

6.2.4 Local lighting fixtures in accommodation spaces, as well as socket outlets shall take power from the lighting switchboard by a separate feeder, other than that intended for supplying the common lighting fixtures.

6.2.5 If the ship is divided into main fire zones, then lighting of each zone shall be supplied by two feeders supplying the lighting circuits in other fire zones.

The lighting feeders shall be installed, as far as possible, in such a manner that a fire in one zone cannot damage the feeders supplying the lighting circuits in other zones.

In case of application of the lighting subdivided busbars in the main switchboard, these feeders shall be supplied from different busbar sections.

6.2.6 The main lighting circuits shall be arranged so that fire or any emergency in the spaces accommodating the main sources of power and/or main lighting transformers, if any, will not cause failure of the emergency lighting.

6.2.7 Permanently installed lighting fixtures in holds shall take power supply from a special switchboard. Apart from the switchgear and protective devices, this switchboard shall be provided with light signals to indicate switching-on of each individual lighting circuit.

For ships with low power electrical installations the lighting fixtures in holds may be supplied from the switchboard located in the wheelhouse; in this case, visual alarm is required on voltage availability in the power supply circuit of lighting fixtures in holds.

6.3 EMERGENCY LIGHTING

6.3.1 The illumination obtained from the emergency lighting fixtures in separate spaces, locations and zones listed in 9.3.1.1 and 19.1.2.1.1 shall at least be equal to 10 % of the general illumination obtained from the main lighting fixtures (refer to 6.7). It is permitted that the illumination from the emergency lighting fixtures in the machinery space is equal to 5 % of the main illumination if the socket outlets fed from the emergency lighting circuit are provided.

The illumination shall be sufficient to easily find one's way to the means of escape (or shall be equal to 0,5 lx).

6.3.2 To obtain the illumination required in 6.3.1, the emergency lighting fixtures with incandescent lamps may be combined with luminescent lamps.

6.3.3 The main lighting fixtures are permitted for use as emergency lighting fixtures if they may be also fed from the emergency sources of electrical power.

6.3.4 The emergency lighting circuit shall be so arranged that in case of a fire or other casualty in the spaces containing the emergency sources of electrical power and/or emergency lighting transformers the system of the main lighting will not fail.

6.3.5 For emergency lighting use could be made of the stationary lighting fixtures with built-in accumulators, automatic recharging from the main lighting circuit.

6.3.6 Emergency lighting fixtures or a combined lamp shall be marked in red in visible parts.

6.4 SWITCHES IN LIGHTING CIRCUITS

6.4.1 Two-pole switches shall be used in all lighting circuits.

In dry accommodation and service spaces it is allowed to use single-pole switches in circuits disconnecting individual lighting fixtures or groups of lighting fixtures rated at not more than 6 A and also in lighting fixture circuits designed for safety voltage.

6.4.2 For permanently installed external-illumination lighting fixtures, provision shall be made for switching off all the lighting fixtures from the wheelhouse or from any other permanently watched station on the upper deck.

6.4.3 The switches of lighting circuits of the fire extinction stations shall be located outside these spaces.

6.4.4 The lighting switches behind free-standing switchboards shall be installed near each access door behind the switchboard.

6.4.5 In emergency lighting circuits local switches shall not be used.

The use of local switches is permitted in circuits of such emergency lighting fixtures, which under normal conditions serve as the main lighting fixtures.

A switch shall be provided for emergency lighting in the wheelhouse.

Emergency lighting fixtures of embarkation stations, which under normal conditions serve as main lighting fixtures shall switch on automatically if the ship is de-energized.

6.5 GAS DISCHARGE LAMP INSTALLATIONS

6.5.1 Reactors and capacitors of gas discharge lamp installations shall be protected by securely earthed metal enclosures.

6.5.2 Capacitors of 0,5 μ F and over shall be fitted with discharging devices. The discharging device shall be so designed that the voltage of the capacitor does not exceed 50 V in 1 min after disconnection from supply.

6.5.3 Reactors and transformers having a high inductive reactance shall be installed as close as possible to the lighting fixture they serve.

6.5.4 Gas discharge lamp installations supplied at over 250 V shall be provided with warning notices giving the voltage rating. All live parts of such installations shall be suitably protected.

6.6 SOCKET OUTLETS

6.6.1 Socket outlets for portable lighting fixtures shall be installed at least:

- on deck near the windlass;
- in the gyrocompass room;
- in the radio equipment converter room;
- in the steering gear compartment;
- in the emergency generator set compartment;
- in the machinery spaces;
- behind the main switchboard;
- in special electrical spaces;
- in the propeller shaft tunnel;
- in the wheelhouse;
- in the radioroom;
- in the vicinity of winches;
- in the vicinity of the log and echo-sounder trunk or recess;
- in spaces where centralized ventilation and air conditioning installations are located.

6.6.2 Socket outlets fed with different voltages shall be so designed as to prevent insertion of a plug intended for one voltage into a socket intended for higher voltage.

6.6.3 Socket outlets for portable lighting and other electric appliances installed on the open decks shall be mounted with their face looking downward.

6.6.4 Socket outlets shall not be fitted in machinery spaces below the plating, in enclosed fuel and oil separator rooms or where approved safety-type equipment is required.

6.7 ILLUMINATION

6.7.1 The illumination of particular spaces and zones shall not be below that specified in Table 6.7.1. This requirement is not applicable to ships provided with lighting circuits supplied at a voltage below 30 V.

The general lighting standards stated in Table 6.7.1 refer to a level of 800 mm above the deck (flooring) of the space, while the standards of general plus local lighting, to the level of working surfaces.

6.8 NAVIGATION LIGHTS

6.8.1 The navigation lights switchboard shall supply by separate feeders the masthead lights, sidelights and sternlight, and in towing, pushing, fishing, pilot vessels, vessels restricted in ability to manoeuvre and air-cushion vehicles it shall supply also permanently mounted lights listed in Table 2.4.1, Part III "Signal Means" of the Rules for the Equipment of Sea-Going Ships, and additional masthead and stern lights listed in Table 5.2.1 of the said Part of the Rules.

6.8.2 The navigation lights switchboard shall be supplied by two feeders:

.1 one feeder from the main switchboard through the emergency switchboard;

.2 the second feeder from the nearest distribution board, which is not supplied from the emergency switchboard.

It is permitted to install the navigation lights control devices in the integrated bridge control console and taking the power in accordance with 4.5.2.

Table 6.7.1

Nos	Spaces and surfaces		Illumination, lux			
			Luminescent lighting		Incandescent lighting/LED lamps	
			general + local	general	general + local	general
1	Radio communication station	At the predetermined level above the deck	—	—	—	100
		Operator tables in radio communication station	—	—	200	—
2	Chartroom	At the predetermined level above the deck	—	100	—	50
		Chart tables	150	—	150	—
3	Wheelhouse	At the predetermined level above the deck	—	75	—	50
4	Machinery spaces, spaces for switchboards, manoeuvring and control stations and panels, spaces for automation facilities and gyrocompasses	At the predetermined level above the deck plating	—	75	—	75
		Surfaces of switchgear and control desks	200	100	150	75
		Main engine controls	150	100	150	75
		Passageways between boilers, machinery, ladders, platforms, etc.	—	75	—	30
		In front of boilers	100	75	75	75
5	Battery compartment	At the predetermined level above the deck	—	75	—	50
6	Propeller shaft tunnels, log, echo sounder trunks, chain lockers	At the predetermined level above the deck	—	50	—	20
		Surfaces of shaft bearings and connection flanges, etc.	75	—	50	—
7	Passageways on decks, gangways and lifeboat and liferaft positions	At the predetermined level above the deck	—	50	—	20
8	Overboard spaces in way of lifeboat and liferafts launching	Near the load waterline	—	—	—	5

Where the main source of power of the ship is an accumulator battery and the main switchboard is installed in the wheelhouse, the navigation lights may be controlled directly from the main switchboard.

6.8.3 Navigation lights shall be connected to power supply by a flexible cable with a plug connector. On board ships where double lights are installed they may be connected to power supply by a cable without a plug connector.

6.8.4 The power supply of navigation lights shall be of two-wire system with a double-pole switch for each circuit to be installed in the navigation light switchboard.

6.8.5 Each navigation light power supply circuit shall be provided with protection in both wires and with indication of the navigation light switching in compliance with the requirements of 4.1.4, Part III "Signal Means" of the Rules for the Equipment of Sea-Going Ships.

The indication device of the navigation light switching shall be so designed and installed that its failure does not cause the navigation light disconnection.

The voltage drop at the distribution board supplying navigation lights including the system of indicating the lights operation shall not exceed 5 % at rated voltage up to 30 V and 3 % at rated voltage above 30 V.

6.8.6 Independent of the navigation light switching indication referred to in 6.8.5, provision shall be made for visual and audible alarms operating automatically in case of failure of any navigation light with the switch in the "on" position.

Alarms shall be supplied from a source or feeder other than that used for power supply to navigation light switchboard or from an accumulator battery.

6.8.7 Lamp holders and lamps used in navigation lights shall comply with the requirements of 3.1.7, Part III "Signal Means" of the Rules for the Equipment of Sea-Going Ships.

6.9 LIGHTING AND ILLUMINATION MEANS OF HELIDECKS

6.9.1 General.

6.9.1.1 The lighting and illumination means for helidecks shall at least provide for the following:

indication of the perimeter (boundaries) of the helideck;

illumination of the landing area;

indication of the elevated structures within the landing area.

6.9.1.2 Lights used for this purpose shall be protected to not lower than level IP56 and shall function reliably under environmental effects mentioned in Section 2.

6.9.1.3 All lighting and illumination means as well as other electrical equipment within helicopter refuelling stations and hangars shall be of certified safe type and designed to not lower than the temperature class T3 and subgroup IIA.

6.9.1.4 In respect to their lighting characteristics and arrangement, the lights shall meet the requirements of ICAO (International Civil Aviation Organization) which shall be confirmed by the appropriate conclusion or by a Certificate of the Civil Aviation competent body.

6.9.1.5 The lighting and illumination means mentioned in this Chapter shall be fed by uninterruptible power supply.

6.9.2 Perimeter lights.

6.9.2.1 The lights shall be divided into two independent circuits and supplied in such a manner that when the power to any one circuit fails, 50 % of lights to indicate the perimeter remain functioning.

6.9.3 Illumination of the landing area.

6.9.3.1 The landing area and wind direction indicator shall be properly illuminated. For this purpose, floodlights may be used.

6.9.3.2 Helideck floodlights shall be located so as to avoid glare to pilots during take-off, landing and maneuvering.

6.9.4 Obstruction/warning lights.

6.9.4.1 To provide flight safety, all considerably elevated structures and items such as superstructure components, drill and production strings, etc. shall be marked by special obstruction/warning red lights.

6.9.4.2 Lights shall be divided into several independent circuits and supplied in such a manner that when power supply to one of the circuits fails, the basic part of the obstruction/warning lights remains functioning.

7 INTERNAL COMMUNICATION AND SIGNALLING

7.1 ELECTRIC ENGINE ROOM TELEGRAPHS

7.1.1 In addition to the requirements of the present Chapter, the engine room telegraphs shall meet the requirements of 3.3.1, Part VII "Machinery Installations".

7.1.2 Engine room telegraphs shall be provided with visual alarm on voltage availability in the power supply circuit and audible alarm on loss of voltage in the power supply circuit.

7.1.3 Engine room telegraphs installed in the wheelhouse shall be provided with an illuminated dial of regulated illumination.

7.1.4 Engine room telegraphs shall be fed from the main switchboard or from the navigation equipment switchboard.

If the ship is provided with the integrated bridge control console the engine room telegraph may be fed from this control console.

7.1.5 The engine room telegraph transmitter shall be so installed in the wheelhouse that when orders are given out for ship's motion, the telegraph operating handle is shifted in the same direction with the ship. Vertical position of the handle shall correspond to the "stop" order.

7.1.6 Where engine room telegraphs and devices for remote control of the main engines and the controllable pitch propellers are installed on sloping desks of control panels, the handle in the "stop" position shall be perpendicular to the panel surface and be fixed precisely in this position.

7.1.7 Where two and more engine room telegraphs are located in close proximity to one another (on one deck), they shall ensure the transmission of an order from any telegraph and the reception of order by all of them simultaneously, without additional changing-over.

Change-over to telegraphs located on another deck or in another part of the ship shall be effected with the use of switches fitted on the navigation bridge.

7.1.8 Each engine room telegraph shall be provided with an audible signal arrangement that will ensure the operation of an audible signal on the bridge and transmission of orders and reception thereof in the engine room. In case of a wrong reply, the operation of the audible signal arrangement shall not stop (refer also to 3.3.1, Part VII "Machinery Installations").

7.2 INTERNAL SERVICE COMMUNICATION

7.2.1 The system of internal service communication (refer to the requirements below) shall provide a subscriber call and clear voice communication under the normal and emergency ship's operation conditions, as well as under specific noise conditions in places where the communication facilities are installed.

7.2.2 Sound-powered telephones, voice communication facilities, two-way loud-speaking communication facilities, automatic telephone systems or mobile phones of a local network may be used in the system of internal service communication.

7.2.3 The system of internal service communication shall provide voice communication between the wheelhouse and main service spaces and stations. In this case the separate two-way voice communication may be omitted if the communication facility provides at any time the call priority and communications between the wheelhouse and the following main service spaces and stations:

- .1 main machinery control room;
- .2 local control stations of the main machinery and propellers (for this purpose the two-way telephone communication between the wheelhouse and the main machinery control room with telephones connected in parallel and fitted at local control stations may be used);
- .3 radioroom (may be omitted where communication may be established without hardware);
- .4 steering gear compartment;
- .5 space containing the emergency switchboard;
- .6 forecastle and poop stations;
- .7 gyrocompass room;
- .8 fire smothering station (refer also to 3.1.3.2.6, Part VI "Fire Protection");
- .9 space containing electric propulsion motors;
- .10 cargo operations control station (in oil tankers);
- .11 fire and rescue control station (in ships with distinguishing mark of provision with means for fire fighting aboard other ships in the class notation);
- .12 other spaces where equipment ensuring ship's safe navigation is installed.

7.2.4 Provision shall be made for communications between the main machinery control room or local control stations of the main machinery and propellers and the engineers' accommodations.

7.2.5 For the communication facilities specified in 7.2.3 and 7.2.4, in addition to sound-powered telephones, provision shall be made for power supply from

the main source of electrical power and accumulator battery actuated automatically in case of failure of the main source of electrical power with a capacity sufficient to supply the communication facilities during the time specified in 9.3.1.3 or 19.1.2.1.4.

7.2.6 The communication facilities between the wheelhouse and the main machinery control room or local control stations of the main machinery and propellers shall include an additional audible and visual alarm to indicate the call both in the main machinery control room and the engine room.

7.2.7 A damage to, or disconnection of one communication facility shall not interfere with the functioning of other communication facilities.

7.3 SIGNALLING. GENERAL

7.3.1 The requirements cover the following systems signaling the equipment or ship's condition requiring attention of personnel or passengers, activating an audible and visual alarm:

- .1 general alarm and fire alarm systems;
- .2 fire detection and fire alarm system;
- .3 release indication of fire smothering system;
- .4 indication of closing of watertight and fire doors and also the doors indicated in 7.12;
- .5 machinery alarm system;
- .6 high level of bilge water alarm;
- .7 cargo hold water level alarm on bulk carriers, passenger ships carrying 36 persons and more and single-hold cargo ships other than bulk carriers;
- .8 engineer's alarm;
- .9 personnel alarm, cargo control alarm and alarm of ultimate concentration of dangerously explosive and noxious gases;
- .10 side port doors condition alarm;
- .11 alarm on presence of people inside refrigerated holds: "Man in hold" alarm (for ships used for processing the living resources of the sea and not engaged in their catching);
- .12 sewage holding tanks level alarm;
- .13 release indication of fixed local application fire extinguishing system;
- .14 bulkhead shaft glands, bearing and pump case temperature alarm system;
- .15 maximum permissible cargo temperature alarm system;
- .16 overpressure or under pressure in the cargo tanks alarm system;
- .17 high- and limit-level alarms in cargo tanks.

7.3.2 An opportunity to functionally test each alarm system shall be provided.

Unless otherwise stated, all alarm systems shall be designed on the fail safe principle with provision

for power supply failure alarm, alarm on contact-to-frame fault or circuit break, as well as the possibility of checking visual and audible alarms operability.

7.3.3 The control panel shall clearly distinguish between normal, alarm, acknowledged alarm, fault and silenced conditions. The system shall be arranged to automatically reset to the normal operating condition after alarm and fault conditions are cleared.

7.3.4 Audible alarms shall be heard and distinguishable in all the spaces and areas they intended for.

7.3.5 Audible alarms of an alarm system shall be given until their acceptance (acknowledgement) is confirmed, and the visual indication of each separate alarm shall remain until the fault has been corrected.

7.3.6 The sound frequency of audible alarm devices, excepting a bell, shall be within the range of 200 to 2500 Hz.

7.3.7 Where the visual alarm is applied, the colours specified in Table 4.6.5.1 shall be used unless otherwise stated.

7.3.8 The height of inscription text symbols for operating and alarm controls, unless they have been duplicated with symbols/a plate of an established pattern, shall be at least 7 mm, the width is 0,7 symbol height.

This requirement, excepting the visual alarms mentioned in 7.3.1, also applies to the texts of inscriptions above the controls in switchboards, control consoles, starting, protection and control equipment for electric drives of essential machinery listed in 1.3.2.1.5.

7.3.9 The texts of inscriptions above operating and alarm controls not mentioned in 7.3.8, as well as the texts of watch-keeping and other instructions used for the description of a working procedure, starting and control of an object shall have symbols of at least 3,5 mm high, the width is 0,7 symbol height.

7.3.10 Flashing alarms shall emit light within 50 % of the entire work cycle, the pulse frequency therewith shall be within the range of 0,5 to 1,5 Hz.

7.4 GENERAL ALARM SYSTEM

7.4.1 In addition to the requirements stated below, the general alarm system shall comply with the requirements of 2.1.3 and 6.22.1, Part II "Life-Saving Appliances" of the Rules for the Equipment of Sea-Going Ships.

7.4.2 Sound devices shall be installed in the following places:

- in machinery spaces;
- in public spaces, if their floor area is more than 150 m²;

in corridors of accommodation, service and public spaces;

on open decks of passenger ships;
in working spaces.

7.4.3 General alarm system shall be supplied from the ship mains and the busbars of the emergency distribution board in conformity with 9.3.1.3 and 19.1.2.1.4.

General alarm system may be energized from the ship mains and from an independent accumulator battery if provision is made for an automatic changeover of general alarm circuits to the battery. In this case, no supply either from the emergency source or from an intermediate emergency source of electrical power is necessary.

7.4.4 The general alarm system shall be energized continuously, no matter if the accumulator battery is set in position for charging or discharging.

7.4.5 In case a separate accumulator battery is used for supply of the general alarm system, it may also energize other internal communication and signalling facilities if the battery capacity is sufficient for simultaneous supply of all consumers for at least 3 h and also if these facilities are so designed that a damage to one circuit will not interfere with operation of other circuits provided no longer supply time is required for those facilities.

7.4.6 In circuits supplying the general alarm system the protection only from short circuit shall be provided. Protective devices shall be fitted in both conductors of the feeder and also in circuits of each sound device.

Protection of several sound devices by one common protective device is permitted if in spaces where they are installed good audibility of other sound devices provided with independent protection is ensured.

7.4.7 General alarm sound devices shall be so located that a signal is clearly heard against the noise in the given space. Sound devices installed in spaces with high intensity of noise shall be fitted with luminous indicators.

The sound of general alarm devices shall differ in tone from the sounds of all other kinds of signalling. With the exception of bells, audible alarms shall have a sound frequency between 200 and 2500 Hz. Facilities may be provided for regulating the audible signal frequency within the above limits.

7.4.8 The general alarm system shall be actuated by means of a double-pole switch.

If the general alarm signal is not heard from the wheelhouse or from the station where it has been given, a pilot lamp shall be fitted after the switch to indicate that the general alarm system is activated.

The switches shall be provided with the inscriptions indicating their purpose.

7.4.9 No switching devices shall be incorporated into the circuits of the general alarm system other

than the switch specified in 7.4.8. Where a power supply switch is installed on the general alarm system switchboard, provision shall be made for its interlocking in the "on" position or it shall be otherwise protected against access thereto of unauthorized persons.

It is permitted to use intermediate contactors controlled by the switch, but not more than one contactor in each loop.

7.4.10 Sound devices, switches and distribution devices of the general alarm system shall be provided with readily visible distinctive symbols.

7.4.11 The general alarm system shall consist of at least two loops controlled by one switch. Short-circuit protection shall be provided at both poles of each loop of the general alarm system.

7.4.12 Sound devices connected to different loops of the general alarm system shall be fitted in large area spaces (machinery spaces, boiler rooms, fish-processing shops, etc.).

7.5 FIRE DETECTION AND FIRE ALARM SYSTEM

7.5.1 Fire detection and fire alarm systems used on ships shall be of the Register-approved type and, in addition to the requirements of the present Chapter, meet the requirements of 4.2.1, Part VI "Fire Protection" and of the Fire Safety Systems Code (refer to 1.2, Part VI "Fire Protection").

7.5.2 Application of fire detectors located in spaces where explosive vapours may accumulate or in a flow of air sucked out of these spaces is regulated by 2.9, 19.2 to 19.4.

7.5.3 There shall be not less than two sources of power supply for the electrical equipment used in the operation of the fixed fire detection and fire alarm system, one of which shall be an emergency source. The supply shall be provided by separate feeders reserved solely for that purpose. Such feeders shall run to an automatic change-over switch situated in or adjacent to the control panel for the fire detection system. Operation of the automatic changeover switch or failure of one of the power supplies shall not result in degradation of the fixed fire detection and fire alarm system. Where the fixed fire detection and fire alarm system would be degraded by the momentary loss of power, a source of stored energy having adequate capacity according to 9.3.7 shall be provided to ensure the continuous operation during changeover between power supplies.

The fixed fire detection and fire alarm system emergency power may be supplied by an accumulator battery or from the emergency switchboard. The emergency source of power shall be sufficient to

maintain the operation of the fire detection and fire alarm system for the periods required under 9.3.1.5 or 19.1.2.1.5, as applicable. At the end of that period, it shall be capable of operating all connected visual and audible fire alarm signals for a period of at least 30 min. Where the system is supplied from accumulator batteries, they shall be located in or adjacent to the control panel for the fire detection system, or in another location suitable for use in an emergency. The rating of the battery charge unit shall be sufficient to maintain the normal output power supply to the fire detection system while recharging the batteries from a fully discharged condition. Where the emergency feeder for the electrical equipment used in the operation of the fixed fire detection and fire alarm system is supplied from the emergency switchboard, it shall run from this switchboard to the automatic changeover switch without passing through any other switchboard.

7.5.4 The smoke detection system based on air sampling (refer to 4.2.1.6, Part VI "Fire Protection") and the fans of this system shall be fed by separate feeders from the main and emergency sources or another independent source of electrical power.

7.5.5 Indicating units of the fire detection and fire alarm system, other than those indicated in 7.5.4, shall be designed in such a manner that:

.1 any signal or damage to one circuit does not influence normal operation of other circuits;

.2 a fire detection signal shall prevail over other signals fed to the indicating unit and to make it possible to determine the location of the space wherefrom this fire detection signal has arrived;

.3 contact-type fire detector circuits are normally closed; it is permitted to use detectors with normally open circuits if the contacts are hermetically sealed and permanent damage control of the circuits is effected;

.4 provision is made for monitoring its operation.

7.5.6 Indicating units of the fire detection and fire alarm system shall produce information specified in Table 7.5.6.

A visual signal of fire detection shall be executed in such a manner that it consists of two indicators (two lamps or a double filament), or a special device shall be provided to check the proper condition of signalling lamps. The colour of a light signal shall comply with the requirements of 4.6.5.

Visual signals shall be separate for each kind of information.

Signals intended to determine the location of the space or area wherefrom a pulse has arrived may be common with the signal of fire detection or damage.

Visual signals shall function from the moment a pulse is received till the moment the cause of their operation has been removed; the signal specified in item 1 of Table 7.5.6 shall function continuously irrespective of the nature of supply.

7.5.7 The fire detection and fire alarm system shall meet the following requirements:

.1 the activation of any automatic detector or manually operated call point shall initiate a visual and audible signals at the control panel and indicating units. If the signals have not received attention within 2 min, an audible alarm shall be automatically sounded throughout the crew accommodation and service spaces, control stations and machinery spaces of category A. This alarm sounder need not be an integral part of the fire detection and fire alarm system;

.2 the control panel shall be located on the navigation bridge or in the continuously manned main machinery control room, and in the cargo control room, if any. One indicating unit shall be located on the navigation bridge if the control panel is located in the main fire control station;

.3 indicating units shall, as a minimum, denote the section in which an automatic detector has

Table 7.5.6

Nos	Signalling of operating conditions and faults	Signal of using temperature fire detection and fire alarm system	Signal of using systems, in which air from protected spaces enters indicating units
1	Operation of device	Visual	Visual
2	Power supply from emergency source	Visual	Visual
3	Signals of fire and location of area or space where outbreak of fire is detected	Audible	Audible
4	No draught in detection chamber	Visual	Visual
5	No draught in pipelines	—	Visual
6	Disconnection in detector circuits	—	Audible
7	Location of faults in detector circuit	Visual	Visual ¹
8	Off position of detector circuit ¹	—	—
9	Main power supply failure	Visual	—
		Audible	Audible

¹Recommended.

activated or manually operated call point has operated;

.4 clear information shall be displayed on or adjacent to each indicating unit about the spaces covered and the location of the sections.

7.5.8 Fire detection and fire alarm systems with a zone address identification capability shall be so arranged that:

.1 no loop shall pass through a space more than once to prevent its damage at more than one point by a fire. When this is not practical (e.g. for large spaces), the parts of the loop passing through the space for the second time shall be installed at the maximum possible distance from the other parts of the loop;

.2 means are provided to ensure that any fault (e. g. power break, short circuit, earth) occurring in the loop will not render the whole loop ineffective. It means that a fault occurring in the loop only renders ineffective a part of the loop not being larger than a section of a system without means of remotely identifying each detector;

.3 all arrangements are made to enable the initial configuration of the system to be restored in the event of failure (electrical, electronic, informatic);

.4 the first initiated fire alarm will not prevent any other detector to initiate further fire alarms.

7.5.9 The fire detectors containing ionising radiation sources (radioactive isotopes) shall have a certificate confirming their radiation safety issued by a competent body.

7.5.10 Detectors shall meet the following requirements:

.1 automatic detectors shall be operated by heat, smoke or other products of combustion, flame, or any combination of these factors. The possibility of using automatic detectors operated by other factors indicative of incipient fires may be considered by the Register provided they are no less sensitive than the above detectors. Flame detectors shall only be used in addition to smoke and heat detectors;

.2 smoke detectors required according to 4.2.1.1, Part VI "Fire Protection" shall operate before the smoke density exceeds 12,5 % obscuration per metre, but not until the smoke density exceeds 2 % obscuration per metre. Smoke detectors fitted in machinery spaces of category A shall operate before the smoke density reaches 50 % obscuration per metre;

.3 heat detectors fitted in spaces with a normal air temperature shall operate within the temperature limits of 54 to 78 °C when the temperature is increased to those limits at a rate less than 1 °C per min. The Register may consider the possibility of using heat detectors with higher rates of temperature increase taking into account their sensitivity;

.4 the temperature of heat detectors activation in drying rooms and similar spaces, which are characterized by high temperatures, may be set up to 130 °C inclusive, and in saunas up to 140 °C inclusive;

.5 heat detectors shall reliably operate at a temperature at least by 5 °C in excess of the temperature at which the sensor is set;

.6 in machinery spaces of category A the detectors may be used which reveal a seat of fire on appearing temperature pulsation (heat-pulse detectors). They shall be set to a temperature pulse frequency of 1,9 to 2,3 Hz and above, and operate when an amplitude is exceeded by $(2 \pm 0,5)$ °C whatever a space temperature may be;

.7 the type of all automatic detectors shall be so chosen that after the operation test they come back to normal operation without any components being replaced.

7.5.11 Sections and their cables shall meet the following requirements:

.1 automatic detectors and manually operated call points shall be grouped into sections;

.2 a section of automatic fire detectors which covers a control station, a service space or an accommodation space shall not cover a machinery space of category A and cargo spaces of ro-ro ships. In case the fire detection and fire alarm system is fitted with individually identifiable fire detectors, a loop covering sections of automatic fire detectors in accommodation spaces, service spaces and control stations shall not serve machinery spaces of category A and cargo spaces of ro-ro ships;

.3 where the fire detection and fire alarm system is not fitted with individually identifiable fire detectors, no section covering more than one deck within accommodation spaces, service spaces and control stations shall be permitted except the section serving an enclosed stairway. A number of enclosed spaces served by one section shall not exceed 50. In case the fire detection and fire alarm system is fitted with individually identifiable fire detectors, the sections may cover several decks and serve any number of enclosed spaces;

.4 a section shall not contain more than 100 detectors;

.5 cables of sections, including their feeding cables, being part of the system shall be so arranged as to avoid galleys, machinery spaces of category A, and other enclosed spaces of high fire risk except where it is necessary to provide fire detection or fire alarm in such spaces (refer to 16.8.1.8).

7.5.12 A fire detection and fire alarm system for periodically unattended machinery spaces of category A shall be so designed and the automatic detectors so positioned as to quickly detect the fire in any part of those spaces and under any normal operation

conditions of machinery and variations of ventilation. Except in spaces of restricted height and where their use is especially appropriate, fire detection and fire alarm systems using only thermal detectors shall not be permitted. The fire detection and fire alarm system shall initiate audible and visual alarms, distinct from those of any other system not indicating fire, in sufficient number of places to ensure that the alarms are heard and observed on the navigation bridge and by a responsible engineer officer. When the navigation bridge is unmanned, the alarm shall sound in a continuously manned place.

7.5.13 A fire detection and fire alarm system for unattended machinery spaces of category A, as required in 4.2.3, Part VI "Fire Protection", shall meet the following requirements:

.1 an indicating unit shall be installed on the navigation bridge, in the fire control station or another accessible place protected against fire in a machinery space of category A;

.2 a visual alarm on the indicating unit shall indicate the location (zone) of fire;

.3 a fire alarm shall initiate visual and audible alarms distinct from those of any other system which shall be provided at the locations sufficient to be heard and observed by the watch officer on the navigation bridge and by the responsible engineer officer;

.4 in case of power supply failure or any fault in the system, the audible alarm shall be initiated in addition to the visual alarm;

.5 the type and arrangement of detectors shall ensure quick detection of fire and prevent misoperation under normal conditions of machinery space. Provision shall be made for detectors of at least two types operating by different factors of fire detection. In spaces of less than 2,5 m in height only the use of heat detectors is permitted;

.6 the arrangement of detector sections shall provide for the indication of fire location. An air movement due to machinery operation shall not affect the efficient operation of the fire detection and fire alarm system;

.7 detectors with controlled sensitivity shall have fixing arrangement and an indicator of the preset sensitivity;

.8 where provision is made for temporarily cutting off an individual detector or a section of detectors, this shall be clearly indicated. When a preset period of time expires, the switching-off detector or section of detectors shall automatically switch on;

.9 facilities shall be provided to release the fire alarm from the following locations:

.9.1 corridors having entrances to machinery spaces of category A;

.9.2 a wheelhouse;

.9.3 a control station in the machinery space.

7.6 RELEASE INDICATION OF FIRE SMOTHERING SYSTEM

7.6.1 The release indication system shall comply with the requirements of 4.3, Part VI "Fire Protection".

7.6.2 The release indication system shall be energized from two independent (main and emergency) sources of power. An accumulator battery having a capacity sufficient for feeding the system during 30 min may be used as an emergency source of power. Provision shall be made for automatic change-over of power supply for the release indication system to the emergency source in case of disappearance of voltage from the main source.

7.7 INDICATION OF CLOSING WATERTIGHT AND FIRE DOORS

7.7.1 Indication of closing watertight doors as required in 7.1.9, 7.1.11, 7.1.13, 7.12.4 to 7.12.6, Part III "Equipment, Arrangements and Outfit" shall meet the following requirements:

.1 at the navigation bridge, watertight door control stations and in the immediate vicinity of them the visual indicator system for door position shall be provided;

.2 the visual and audible alarm to provide control over the door closing shall be fitted;

.3 the power supply for indicator system of door position and for the alarm system shall be independent of the power supply for operating and closing the doors and shall be provided with a backup power supply from the emergency source of power (e.g. uninterruptible power supply).

7.7.2 Indication of position of fire doors as required in 2.2.3.3, 2.2.4 and 3.1.2.3, Part VI "Fire Protection" shall meet the following requirements:

.1 at the navigation bridge the visual indicator system for each door position shall be provided;

.2 remote-released sliding doors or power operated doors shall be equipped with an alarm that sounds during 5 — 10 s after the door is released and until is completely closed;

.3 the power supply for indicator system of door position and for the alarm system shall be independent of the power supply for operating and closing the doors and shall be provided with a backup power supply from the emergency source of power (e.g. uninterruptible power supply).

7.8 SOUND SIGNALS IN ENGINEERS' ACCOMMODATION SPACES

7.8.1 In the engineers' accommodation spaces the sound signalling system shall be provided for the

emergency call of the engineer, which is actuated manually from the main engines control station in the engine room or from the main machinery control room, if any.

7.9 PERSONNEL ALARM

7.9.1 In ships where engineering watch is maintained by one person, or in ships with unattended machinery space, personnel alarm shall be provided, and in this case:

.1 the alarm system shall monitor safe and efficient condition of the machinery space personnel at least every 30 min;

.2 the alarm signal shall be transmitted to machinery spaces. If the signal is not acknowledged within 3 min, an appropriate signal shall be transmitted to navigation bridge and to accommodation, service and public spaces where machinery attending personnel might be staying;

.3 the alarm shall be put into operation by personnel attending machinery installation, when one person stays in the machinery space, and shall be disconnected after he leaves the space.

.4 the system shall also meet the requirements in 2.4.1.14, Part XV "Automation".

7.10 CARGO HOLD WATER LEVEL ALARM SYSTEM ON BULK CARRIERS, PASSENGER SHIPS CARRYING 36 PERSONS AND MORE AND SINGLE-HOLD CARGO SHIPS OTHER THAN BULK CARRIERS

7.10.1 Unless otherwise specified in this Chapter, the cargo hold water level alarm system shall meet the requirements of 7.3 of the present Part, as well as 3.4.11, Part V "Subdivision" and 7.9.9, Part VIII "Systems and Piping".

7.10.2 The alarm system shall provide warning and emergency visual and audible alarms to indicate water level in cargo holds and for the ballast tanks and dry spaces, forward of the collision bulkhead — only emergency visual and audible alarms.

The warning alarm shall be activated when the water reaches the lower level with the emergency alarm activated when the water reaches the upper level as mentioned in 7.9.9, Part VIII "Systems and Piping". It is allowed to use one sensor to initiate warning and emergency alarms.

The error in the water level determination by detectors shall not exceed 100 mm.

The warning and emergency audible alarms shall be dissimilar.

The system shall provide clear identification of spaces from which the alarm has been released.

The audible alarm shall be silenced from the alarm panel installed on the navigation bridge.

7.10.3 The alarm system shall be supplied by the main and emergency sources of electrical power. Instead of the emergency source of electrical power an independent, continuously charged from the shipboard charging facility, accumulator battery complying with the requirements for the emergency source of electrical power and capable of supplying the system during at least 18 hours may be used.

In the event of loss of the main or emergency power and of automatic changeover to the emergency power, an emergency warning alarm shall be released.

7.10.4 The system shall be provided with self-monitoring capability. The alarm signal shall be activated when at least the following faults occur: short circuit, circuit break, contact-to-frame fault. For the computer-based systems, alarm shall be additionally provided to indicate the excess program execution time, central processor fault and input-output unit fault.

The system shall provide a possibility of checking the visible and audible alarms.

7.10.5 Provision shall be made in the system for disabling of the alarm in the events when the cargo holds and forepeak are used as water ballast tanks. In case where such ballast tanks are emptied, disabling shall be automatically released when the water level lowers below the level of the lowest detector fitted in the hold concerned.

7.10.6 The alarm system components fitted in cargo holds, ballast tanks and dry spaces shall be corrosion-resistant and protected to not lower than IP68 degree of protection and those fitted on open deck — to not lower than IP56 degree of protection.

7.10.7 Where the alarm system components are fitted in holds intended for the carriage of dangerous goods as well as other goods causing formation of explosive mixtures in the holds, these components and their circuit shall be of intrinsically safe type and protected to not lower than (*Exi*) standard.

7.11 ALARM OF ULTIMATE CONCENTRATION OF DANGEROUSLY EXPLOSIVE AND NOXIOUS GASES

7.11.1 The alarm systems for ultimate concentration of dangerously explosive and noxious gases shall meet the requirements of 9.14.3 and 9.14.4, Part VIII "Systems and Piping", as well as of 7.2.7, Part XII "Refrigerating Plants".

7.11.2 The alarm systems for ultimate concentration of dangerously explosive and noxious gases shall initiate audible and visual alarms in the cargo control room, on the navigation bridge and at the analysing unit when the vapour concentration in a given space

reaches a pre-set value, which shall not be higher than the equivalent of 30 % of the lower flammable limit.

7.11.3 The control panel shall be located in the cargo control room, on the navigation bridge, or in a gas safe continuously manned main machinery control room. Clear information shall be displayed on or adjacent to the control panel to allow the crew to readily determine the source of the alarm or fault condition.

7.11.4 An indicating unit shall be located on the navigation bridge if the control panel is located elsewhere.

7.11.5 The control panel shall have a button or switch to manually reset to normal operating condition after alarm and fault conditions are cleared.

7.11.6 Control panel and indicating unit alarm signals shall be distinct from fault condition signals.

7.11.7 Indicating units may have common alarms servicing multiple sampling points, provided that all sampling points within an alarm group are located in the same space.

7.11.8 Control panels shall have the capability to manually test audible and visual alarms.

7.11.9 Audible and visual alarms shall be initiated on the navigation bridge, at the control panel, and at all indicating units under the following conditions:

.1 upon detection of gas concentrations above the alarm setpoint in any monitored space;

.2 in a fault condition, such as power failure or short-circuit;

.3 low or no flow in any sampling pipe;

.4 tampering with the alarm setpoint; or

.5 failure of any self-test functions in computerized alarm systems.

7.11.10 Computerized systems shall have a self-test function to monitor power supply and volatile memory on start-up and repeated at least once every 24 h.

7.11.11 Audible alarms shall continue until their accepting (quitting) is acknowledged, and visual alarm shall remain in effect while an alarm condition is present.

7.11.12 Electrical components which would reasonably be expected to come into contact with sample gases shall be explosion-proof.

7.11.13 The gas detection equipment shall be so designed that it may readily be tested and calibrated.

7.12 INDICATION OF DOOR POSITION IN RO-RO PASSENGER SHIPS AND RO-RO CARGO SHIPS

7.12.1 Visual and audible alarms shall be installed on the navigation bridge and on each operating panel for closing/opening the doors specified in 7.4, 7.15, Part III "Equipment, Arrangements and Outfit" (visor outer bow doors, folding doors, inner bow doors, side shell and stern doors¹) to provide separate indication of door closed and door fully locked.

The indication panel shall be provided with a lamp test function. The possibility for accidental or unauthorized turning off the indicator light shall be excluded.

7.12.2 The indicator system shall be designed on the fail safe principle and shall include the following:

.1 the indication panels installed on the navigation bridge and at doors' control station shall be provided with:

power supply failure alarm;

earth fault alarm or open-circuit alarm;

a lamp test;

separate indication for door closed, door not closed, door locked and door not locked;

.2 limit switches (door position sensors) closed when the door is closed (when more limit switches are provided for each door they may be connected in series);

.3 limit switches closed when securing arrangements are in place (when more limit switches are provided for each door they may be connected in series);

.4 circuits for the indication of door closed/not closed and for door locked/not locked shall be independent, but may be designed in one multicore cable;

.5 in case of position of limit switches (door position sensors), indication to show: not closed/not locked, securing device is not in place — as appropriate.

7.12.3 The indicator system shall indicate by visual and by audible alarms in the following cases:

.1 if the door is not fully closed, or not fully locked; or

.2 at least one securing device is open or a locking device is unsecured.

7.12.4 The indication panel on the navigation bridge shall be equipped with a mode selection switch "harbour/sea voyage", so arranged that audible alarm is given on the navigation bridge if the vessel leaves harbour with the doors not closed or with any of the securing devices not in the correct position.

7.12.5 The power supply for the indicator system shall be independent of the power supply for operating and closing the doors and shall be provided with a backup power supply from the emergency source of power or any other reliable source (e.g. uninterruptible power supply).

The sensors of the indicator system shall be protected from water, ice formation and mechanical damages, or they shall have respective design resistant to the action of the above factors.

7.12.6 For ro-ro passenger ships, besides the indicator system of door position, provision shall be made of a water leakage detection system with audible alarm and television surveillance, which shall be so arranged as to provide an indication to the navigation

¹Hereinafter referred to as "the doors".

bridge and to the main machinery control room of any leakage through inner, side shell and stern doors.

For ro-ro cargo ships, it is permitted that television surveillance of water leakage through side shell and stern doors is provided from the navigation bridge only.

7.12.7 To control the bow door and the inner bow door position a television surveillance system shall be fitted with a monitor on the navigation bridge and in the main machinery control room. The system shall monitor the position of the doors and a sufficient number of their securing devices. Special consideration shall be given for the lighting and contrasting colour of objects under surveillance.

7.12.8 A drainage system (sumps) shall be arranged in the area between the bow door and the ramp, or where no ramp is fitted, between the bow door and inner door. The system shall be equipped with an audible and visual alarm functions to the navigation bridge for the high water level alarm in the sump or for water level in these areas exceeding 0,5 m, proceeding from the type of structure.

7.12.9 For ro-ro passenger ships engaged in international voyages, the special category spaces and cargo spaces, indicated in 1.5.4.3 and 1.5.9, Part VI "Fire Protection" (in the absence of continuous patrolling or other effective means of monitoring) shall be monitored by means of television surveillance, so that any movement of vehicles in adverse weather conditions or unauthorized access of passengers thereto, may be detected whilst the ship is moving.

7.13 RELEASE INDICATION OF FIXED LOCAL APPLICATION FIRE EXTINGUISHING SYSTEM

7.13.1 Release indication system shall comply with the requirements specified in 3.12, Part VI "Fire Protection".

7.13.2 The system shall be equipped with an audible and visual alarm functions regarding release of fire extinguishing system both in the protected space and in permanently manned stations. Where several fire extinguishing systems are installed the indication system shall clearly indicate the particular system activated.

7.14 TELEVISION SURVEILLANCE AND INDICATION SYSTEM

7.14.1 Television surveillance and indication systems shall comply with the requirements specified in 7.12.6, 7.12.7, 7.12.9 of the present Part and 7.15.5, Part III "Equipment, Arrangements and Outfit".

7.14.2 Generally, television surveillance and indication systems shall include the following:

- .1 TV cameras;
- .2 video displays;
- .3 commutation switchboard;
- .4 movement detectors;
- .5 video recorders.

7.14.3 Television surveillance and indication system shall monitor respective areas and spaces and ensure video transmission to permanently attended control stations. Television surveillance and indication system shall give audible and visual signals when the condition of the monitored item/space is changed.

7.14.4 Television surveillance and indication system shall provide the following alarms:

- .1 power failure;
- .2 television surveillance and indication system failure;
- .3 "TV camera — display" channel failure (short circuit, circuit break);
- .4 TV camera(s) failure;
- .5 movement detector failure;
- .6 video recorder failure.

7.14.5 Television surveillance and indication systems may be of black-and-white or color type. The installation of this or that type depends on the required informative capacity of the system, parameters of the monitored item (location, lighting and other properties) and presumable targets (man, cargo, water and other purposes).

7.14.6 TV cameras transmitting video signals with a "signal/noise" (S/N) ratio not less than 50 dB shall be used in television surveillance and indication systems to minimize the noise on display.

7.14.7 Camera lens projection shall not be less than 480 television lines (tv1) (for color image) or not less than 570 tv1 (for black-and-white image).

For digital cameras the lens resolution shall be not less than 1024 × 756 pixels.

7.14.8 Proceeding from their location TV cameras used in television surveillance and indication systems shall be protected to not lower than the following levels:

- .1 IP22 — for those fitted in the internal service spaces;
- .2 IP44 — for those fitted in machinery spaces;
- .3 IP56 — for those fitted on ro-ro decks and exposed parts of the weather deck.

7.14.9 The installation of TV cameras shall be such that all dead zones are covered.

7.14.10 Within internal spaces, TV cameras shall be fitted in places with minimum temperature difference to reduce condensate formation on camera lens.

7.14.11 TV cameras fitted on the exposed part of the deck shall have a thermo-casing with a sun visor.

7.14.12 Where the lighting of monitored area is below TV camera sensitivity, the item (item area) shall be equipped at night-time with additional visible or infra-red lighting. Therewith, either camera lens shall be not swamped by the lights, or TV cameras with back light compensation (BLC) function shall be used. Where television surveillance and indication system of color type is used, infrared lighting is impermissible.

7.14.13 Displays with a capacity to operate around the clock over a long period of time with a static picture shall be used to display the data received from TV cameras. The display diagonal for multi-image shall be within 15" — 21" with a resolution not less than 800 tvl for black-and-white image (400 tvl for color image) or within 10" — 14" for full-screen image displays with a resolution not less than 600 tvl for black-and-white image (300 tvl for color image).

For LCD monitors, the resolution shall be at least 1280 × 960 pixels at a diagonal of 15" — 21" and at least 1024 × 756 pixels at a diagonal of 10" — 14".

7.14.14 Special type video recorders with a capacity to record over long periods of time or digital video data memory shall be used to record TV image.

7.14.15 The recording time for a 180 min videocassette shall not exceed 24 h with the use of special-type video recorder. The use of special-type video recorder with a longer recording time is only allowed if the recorder will automatically change over to real-time recording when alarm is activated by the movement detector.

7.14.16 Commutation switchboard shall provide priority display of areas where alarm has been activated.

7.15 SEWAGE HOLDING TANKS LEVEL ALARM

7.15.1 Alarm system shall comply with the requirements of Part IV "Ship's Equipment and Arrangements for the Prevention of Pollution by Sewage" of the Guidelines on the Application of Provisions of the International Convention MARPOL 73/78.

7.15.2 Alarm system shall be supplied from the main source of electrical power.

7.15.3 Alarm system shall ensure operation of audible and visual alarm at the stations with permanent watch in case the tank is filled up to 80 %.

7.16 BULKHEAD SHAFT-GLAND, BEARING AND PUMP CASE TEMPERATURE EXCESS ALARM

7.16.1 Bulkhead shaft gland, bearing and pump case temperature excess alarm shall comply with the requirements of 4.2.5, Part VII "Machinery Installations".

7.16.2 Alarm system shall be supplied from the main source of electrical power.

7.17 MAXIMUM PERMISSIBLE CARGO TEMPERATURE EXCESS ALARM

7.17.1 The maximum permissible cargo temperature excess alarm shall comply with the requirements of 9.6.6, Part VIII "Systems and Piping".

7.17.2 Alarm system shall be supplied from the main source of electrical power.

7.18 OVERPRESSURE OR UNDERPRESSURE IN THE CARGO TANKS ALARM SYSTEM

7.18.1 Overpressure or underpressure in the cargo tanks alarm system shall comply with the requirements of 9.7.12, Part VIII "Systems and Piping".

7.18.2 Alarm system shall be supplied from the main source of electrical power.

7.19 HIGH- AND LIMIT-LEVEL ALARMS IN CARGO TANKS

7.19.1 High- and limit-level alarms in cargo tanks shall comply with the requirements of 9.11.5, Part VIII "Systems and Piping".

7.19.2 Alarm system shall be supplied from the main source of the electrical power.

7.19.3 Alarm system shall produce sound and light signals on permanent watch posts when tanks are full at 95 % and 98 % correspondingly.

8 PROTECTIVE DEVICES

8.1 GENERAL

8.1.1 Outgoing circuits of switchboards shall be protected against short circuits and overloads by means of devices installed at the inception of each circuit.

No overload protection is required for the switchboard power supply if the current consumers supplied from this switchboard have individual protective devices, and the power supply cable is selected on the basis of maximum working current.

8.1.2 Protective devices shall be so adapted to the characteristics of the equipment under protection that they operate under inadmissible overloads and short-circuit currents.

8.1.3 The electric protection system shall be discriminative with regard to both the overload currents and the short-circuit currents. Such protection system shall be designed so that its operation could not adversely affect the reliable functioning of ship's generating plant and the power supply of essential consumers. Short-circuit and overload protective devices shall not operate at starting currents of the electrical equipment under protection.

8.1.4 Overload protection shall be provided in:

- .1 at least one phase or positive pole in a two-wire system;
- .2 at least two phases in an insulated three-wire three-phase current system;
- .3 all phases in a three-phase four-wire system.

8.1.5 Short-circuit protection shall be fitted in each insulated pole of a direct-current system or in each phase of an alternating current system.

Short-circuit current protective devices shall be set to operate at not less than 200 % of the rated current of the electrical equipment under protection. Operation of the protective devices may be without time delay or with a time delay necessary for the proper discrimination.

The short-circuit current protective device may be used for the protection of both the electrical equipment itself and its supply cable.

8.1.6 Where cables of reduced cross-sectional area are used in some lengths of power supply circuit, additional protection shall be provided for each of such cables unless the preceding protective device is capable of protecting the cable of reduced cross-sectional area.

8.1.7 Protective devices excluding the possibility of immediate repeated switching after operation of the protection shall not be used in supply circuits of the emergency switchboard, as well as in supply circuits of emergency consumers.

8.1.8 The design of the electronic and computer protection devices of generators and major services shall be such as to ensure easy identification and regulation of their operational settings.

Protection devices shall be equipped with the necessary apparatuses and instruction manuals shall be provided for checking their serviceability and the condition of the settings.

The protection devices of generators and important major services shall be tested once in 5 years to confirm the accuracy of their operation.

8.2 PROTECTION OF GENERATORS

8.2.1 Generators not intended for parallel operation shall be provided with means of protection against overloads and short circuits. Fuses may be used as protective devices for generators rated under 50 kW (kVA).

8.2.2 Generators intended for parallel operation shall be provided at least with the following means of protection:

- .1 against overloads;
- .2 against short circuits;
- .3 against reverse current or reverse power;
- .4 against under voltage.

It is necessary that the devices used for generator overload protection shall be provided with light and sound alarms to operate with a time delay of up to 15 min at the loads from 100 to 110 % of the rated current, and shall be capable of disconnecting the generator under protection after a time delay to suit the generator thermal time constant at the loads from 110 to 150 % of the rated current.

It is necessary that for a setting of the protection to operate at 150 % of the rated generator current the time delay shall not exceed 2 min for an alternating-current generator and 15 s for a direct-current generator. An overload exceeding 150 % of the rated current may be allowed where it is required by operating conditions and is admitted by the generator construction.

Overload protection settings and time delay shall be selected to suit the overload characteristics of the generator prime mover so that the prime mover is capable of developing the necessary output within the time delay period adopted. The protective devices used for generator overload protection shall not prevent the possibility of re-starting the generator immediately.

8.2.3 Automatic and selective disconnect of non-essential services shall be provided in the event of the generator overload. These services shedding may be carried out in one or several steps, depending on the generator overload capacity.

Therewith:

.1 the automatic disconnect is not allowed for primary essential services;

.2 the automatic disconnect is allowed for secondary essential services, provided disconnection will not prevent services required for safety being immediately available when the power supply is restored to normal operating conditions;

.3 the automatic disconnect is allowed for services needed for maintaining the minimum comfort habitability conditions for the crew and passengers on the ship.

Examples of such services are as follows:

cooking;
heating, domestic refrigeration;
domestic ventilation drives;
sanitary and fresh water, etc.

This requirement may be dispensed with in the case of electrical installations of low power.

8.2.4 Reverse-current and reverse-power protection of generators intended for parallel operation shall be selected to suit characteristics of generator prime mover. The respective protection settings shall be in accordance with those specified in Table 8.2.4.

Reverse-power protection for alternating-current generators may be replaced by a different, but not less effective, means of protection. With settings specified in the Table the protection of the types in question shall be activated in 10 s.

Reverse-current protection for direct-current generators shall be installed in the pole opposite to that, in which the equalizer lead is connected. Reverse-power or reverse-current protection shall still be capable of operation when the voltage applied is reduced by 50 % although reverse current or reverse power may have altered values.

Reverse-current and reverse-power protection shall permit transfer of power fed from the ship's mains (as, for example, from cargo winches).

8.2.5 Undervoltage protection shall ensure the possibility of a reliable connection of generators to the busbars at a voltage of 85 % or more of rated voltage and shall exclude the possibility of generator-to-busbar connection at a voltage less than 35 % of rated voltage. Besides, it shall disconnect the

generators in case of reduction of voltage across its terminals in the range from 70 to 35 % of the rated value.

Undervoltage protection shall operate with a time delay for disconnection of generators from busbars in case of reduction of voltage and shall operate without time delay at the attempt to make connection to the generator busbars before the minimum voltage specified above is reached.

8.2.6 For generators with the ratings of 1000 kVA and above, it is recommended that provision shall be made for protection against internal faults, as well as for the protection of the lead connecting the generator to its switchboard and switch. Where the generator and its switchboard are installed in different spaces, such protection is compulsory.

8.2.7 If a turbine-driven direct-current generator is intended for operation in parallel, provision shall be made for tripping the circuit breaker of the generator when the automatic safety device of the turbine operates.

8.2.8 The current settings of protective devices with time delay shall be chosen in such a way that in any case a reliable interruption of short-circuit current is ensured after the prescribed time delay.

8.2.9 It is permitted to use safety devices in excitation systems of generators as protective devices for semiconductor elements.

8.3 PROTECTION OF ELECTRIC MOTORS

8.3.1 Outgoing feeders from switchboards supplying electric motors rated at over 0,5 kW shall be provided with means of protection against short-circuit currents and overloads, as well as with no-voltage protection if the motor need not be automatically restarted.

It is admissible for overload and no-voltage protective devices to be installed in the motor starting apparatus.

8.3.2 The overload protective devices for continuously running motors shall disconnect the motor under protection when the load is in the range from 105 to 125 % of the rated current.

8.3.3 In supply circuits of fire pump electric drives the overload protective devices operating on the principle of electrothermal and temperature relays shall not be used.

Table 8.2.4

Kind of current	Limits of reverse-current or reverse-power protection settings related to generator prime mover	
	Turbine	Internal combustion engine
Alternating	2 — 6 % of rated output of generator, kW	8 — 15 % of rated output of generator, kW
Direct	2 — 6 % of rated current of generator, A	8 — 15 % of rated current of generator, A

The overload protective devices may be substituted by light and sound alarms.

8.4 STEERING GEAR PROTECTION

8.4.1 Only short-circuit current protection shall be provided for electric motors and control systems of electric or electrohydraulic steering gear.

Light and audible warning shall be provided of the motor overload or of any phase failure of the feeder supplying the motor.

8.4.2 Circuit breakers used to protect direct-current motors against short-circuit currents shall be set for release without time delay at currents not lower than 300 % and not higher than 400 % of the rated current of the motor under protection, while those used with alternating-current motors shall be set for release without time delay at currents not lower than 125 % of the peak starting current of the motor under protection.

In case fuses are used as protective devices the rated current for the fuse links shall be one grade of rating higher than it follows from the values specified for the electric motor starting currents.

8.4.3 For electric motors of the drives for the active means of the ship's steering short-circuit and overload protective devices shall be provided.

Overload protective devices of the above mentioned motors shall be fitted with light and sound alarms to warn of the motor overload and shall disconnect the electric motor over the load range specified in 8.3.2.

Short-circuit protection shall be in compliance with the requirements of 8.4.2.

8.4.4 For directly driven electric motors of steering gear, overload protection is permitted for locked rotor periods above 60 s with a setting of not less than twice the full load current of the motor protected.

Where such electric motors obtain their power supply via an electronic converter, e.g. for speed control, and which are limited to full load current are exempt from the requirement to provide overload protection. Alarm at electronic converter overload shall be provided with a setting equivalent to the highest permissible current for the normal operation of steering gear.

8.5 PROTECTION OF TRANSFORMERS

8.5.1 Short-circuit and overload protective devices shall be installed on the supply feeders of transformer primaries. If the supply feeder of the transformer primary is protected against short-circuit currents only, then the supply feeder of the secondary shall be protected against overload.

Transformers rated up to 6,3 kVA may be protected by fuses only.

No overload protection or alarm is required for voltage transformers and supply transformers of the control circuits.

8.5.2 Where transformers are intended for parallel operation, it is necessary that switches shall be provided to disconnect their primaries and secondaries, but not necessarily at the same time.

If such transformers are fed from different main switchboard sections, which may be isolated in service, provision shall be made for an interlock to preclude their parallel operation in case of main switchboard sections isolation.

8.5.3 The switching-over of instrument current transformers shall be so arranged as to prevent the possibility of their secondary windings being on open circuit.

8.6 PROTECTION OF ACCUMULATOR BATTERIES

8.6.1 Means of protection against short-circuit currents shall be provided for accumulator batteries other than those, which are designed to start internal combustion engines.

8.6.2 Each battery charging system shall be provided with protection against battery discharge due to a drop or loss of the charger output voltage.

8.6.3 For accumulator batteries designed for starting internal combustion engines, it is recommended that disconnectors shall be fitted at the start of the circuit on the accumulator side to disconnect the batteries from services (the disconnector may be fitted in one pole).

8.7 PROTECTION OF PILOT LAMPS, VOLTMETERS, CAPACITORS AND VOLTAGE COILS

8.7.1 Pilot lamps, as well as measuring and recording instruments shall be provided with short-circuit protection or short-circuit current limiting devices.

Pilot lamps may have no short-circuit protection of their own, nor short-circuit current limiting devices, provided that all the conditions specified below are met:

- .1 the lamps are enclosed together with the device;
- .2 the lamps are supplied from circuits inside the enclosure of the device;
- .3 the protection of the circuit of the device is rated for current not exceeding 25 A;
- .4 a fault in the lamp circuit is not liable to cause an interruption in the operation of an essential service.

Short-circuit protection or current limiting devices shall be located as close as practicable to the terminals of the device under protection on the supply side.

8.7.2 Radio interference suppression capacitors installed in the circuits of main and emergency switchboards, generators, and essential electrical installations shall be protected against short-circuit currents.

8.7.3 The voltage coils of apparatus and devices for control and protection shall be protected against short-circuit current, but they may have no protection of their own, provided that the conditions specified below are met:

- .1 the coils are enclosed with the device, are under overall protection and belong to the control system of one device;
- .2 the coils are supplied from a device circuit, the protection of which is rated for current not exceeding 25 A.

8.8 PROTECTION OF POWER SEMICONDUCTOR UNITS

8.8.1 Provision shall be made for protecting power semiconductor units from internal and external overvoltage.

8.8.2 Semiconductor element units shall be protected against short-circuit. The overload protection of diodes and semiconductors shall be isolated from the overload protection of power circuits.

8.8.3 Where only one consumer is available, a common overload protection is permitted for diode and semiconductor units, and power circuits.

8.9 RESIDUAL-CURRENT DEVICES (RCD)

8.9.1 To protect personnel against current injury and to protect some kinds of electrical equipment against single-phase earth fault residual-current devices shall be used.

8.9.2 The residual-current devices shall be fitted in the supply circuits of socket outlets intended to feed the portable equipment and in the supply circuits of cabin's socket outlets as well as the socket outlets in public and other spaces with the voltage in excess of the safe one (50 V).

8.9.3 The residual-current devices shall be set to operate at zero sequence current within 10 to 30 mA.

8.9.4 For essential electrical equipment, installation of the residual-current devices is not permitted.

9 EMERGENCY ELECTRICAL INSTALLATIONS

9.1 GENERAL

9.1.1 In each self-propelled ship, an autonomous emergency source of electrical power shall be provided. Such source is not required for ships, in which the main sources of electrical power are accumulator batteries, on condition that at least one of the batteries installed satisfies the capacity and location requirements imposed upon the emergency source of electrical power.

9.1.2 A generator or an accumulator battery may be used as an emergency source of power.

9.1.3 The capacity of the emergency source of power shall be sufficient to supply simultaneously all those services that are essential for the safety of navigation in an emergency. In ships where electrical power is necessary for propulsion, the capacity of the emergency source of electrical power shall be sufficient to restore propulsion to the ship (in conjunction with other machinery, as appropriate) from a dead ship condition within 30 min after blackout.

9.1.4 The possibility shall be provided for functional testing of the complete emergency installation including testing of automatic starting arrangements of the diesel generator.

9.1.5 An indicator shall be mounted in the main machinery control room or on the main switchboard to show when the battery, which serves as an emergency source of electrical power, is being discharged.

9.1.6 The emergency sources of electrical power shall be provided only with short-circuit protection. If the emergency source of power is a generator, in the main machinery control room or in the main switchboard visual and audible alarms shall be fitted to warn of the generator overload.

9.2 SPACES OF EMERGENCY SOURCES OF ELECTRICAL POWER

9.2.1 The spaces of emergency sources of electrical power and of their transformers (if any), of emergency transitional sources of electrical power, emergency distribution switchboard and distribution board of emergency lighting shall be located above the uppermost continuous deck, astern from fore-peak bulkhead (collision bulkhead) and be easily accessible from the open deck. The above mentioned spaces in ships covered by the requirements of Part V "Subdivision" shall be located, as a minimum, at a height of 300 mm above the deepest (damage) waterline.

9.2.2 The arrangement of emergency sources of electrical power and pertinent transformers, if any, of transitional sources of electrical power, emergency distribution board and distribution board of emergency lighting with regard to the main sources of electrical power and pertinent transformers, and with regard to the main distribution board, shall be such that a fire or another emergency in the space of the main source of electrical power, of pertinent transformers, main distribution board or in any machinery space of category A would not hamper the supply, control and distribution of electrical power from the emergency source.

9.2.3 Spaces containing emergency sources of electrical power, pertinent transformers, transitional sources of electrical power, emergency distribution board and distribution board of emergency lighting shall not, where possible, be adjacent to machinery and boiler spaces or to spaces containing the main source of electrical power, pertinent transformers and main distribution board.

In case of adjacent arrangement, the decks and bulkheads separating these spaces shall be constructed in accordance with the requirements of Part VI "Fire Protection" relating to control stations.

9.2.4 Emergency distribution board shall be as close as possible to the emergency source of electrical power.

9.2.5 Where a generator serves as the emergency source of electrical power, the emergency distribution board shall be installed in the same space as the diesel generator except where such an arrangement would adversely affect the distribution board operation.

All starting arrangements, charging facilities and starter accumulator batteries of the emergency unit shall also be installed in this space, provided the requirements of 13.2 are complied with.

9.2.6 The emergency diesel generator space shall be provided with heating appliances to ensure the temperature in the space sufficient for starting, without fail, of the emergency generating set and ventilation in accordance with the requirements of 12.5.3, Part VIII "Systems and Piping".

9.2.7 Where the emergency source of electrical power is an accumulator battery, this battery and the emergency switchboard shall be installed in separate spaces.

The requirements for the battery compartments are given in 13.2.

9.3 EMERGENCY SOURCES OF ELECTRICAL POWER IN CARGO SHIPS

9.3.1 In cargo ships, the emergency sources of electrical power shall supply the following services:

- .1 emergency lighting for:
 - all corridors, stairways and exits from service spaces as well as passenger lift cars and trunks;
 - machinery spaces, main generating stations;
 - all control stations, main and emergency switchboards;
 - emergency diesel generator space;
 - wheelhouse;
 - chartroom and radioroom;
 - stowage positions for emergency and fireman's outfit and also positions where manual fire alarms are fitted;
 - steering gear compartments;
 - positions at fire and sprinkler pumps, emergency bilge pump and starting positions of their motors;
 - cargo pump rooms;
 - helicopter hangars and landing areas;
 - gyrocompass space;
 - medical rooms;
- .2 navigation lights, lights of "Vessel not under command" signal and other lights required by Part III "Signal Means" of the Rules for the Equipment of Sea-Going Ships;
- .3 internal communication means and general alarm signals;
- .4 radio equipment and navigational equipment according to the requirements of Part IV "Radio Equipment" and Part V "Navigational Equipment" of the Rules for the Equipment of Sea-Going Ships where the emergency source of power is a diesel generator;
- .5 fire detection and alarm systems;
- .6 daylight signalling lamps, sound signal means (whistles, gongs, etc.), manual calling and other signals required under emergency conditions;
- .7 machinery and devices mentioned under 3.2.1.2, 3.4.7, 3.7.3.2.1, Part VI "Fire Protection";
- .8 electric drives of watertight doors with their indicators and alarms;
- .9 electric drives of devices holding fire doors;
- .10 electric drive of the launching appliance for the lifeboat specified in 6.20.4.7, Part II "Life-Saving Appliances" of the Rules for the Equipment of Sea-Going Ships.
- .11 other systems, the operation of which would be found necessary by the Register to ensure the safety of the ship and the persons on board.

In ships of unrestricted service and restricted area of navigation **R1** of 300 and above gross tonnage, the emergency sources of electrical power shall ensure the supply of services listed above during 18 h.

Consumers mentioned under 9.3.1.3 to 9.3.1.6 may be supplied from their own batteries arranged as

provided for in 9.2 and having a capacity sufficient to supply those consumers during 18 h.

For ships of gross tonnage 300 and above of restricted areas of navigation **R2**, **R2-RSN**, **R2-RSN(4,5)**, **R3-RSN** and **R3** the required period of 18 h may be reduced to 12 h.

For ships of less than 300 gross tonnage, the period of 18 h may be changed to 6 h in the case of unrestricted service and restricted area of navigation **R1** and to 3 h in the case of restricted areas of navigation **R2**, **R2-RSN**, **R2-RSN(4,5)**, **R3-RSN** and **R3**.

9.3.2 The emergency source of electrical power shall ensure, during 3 h, the emergency lighting of muster and embarkation stations for boarding life-saving appliances on deck and overboard according to 2.3.4 and 2.7.7, Part II "Life-Saving Appliances" of the Rules for the Equipment of Sea-Going Ships.

9.3.3 The supply of steering gear shall be effected from the emergency source of electrical power in accordance with 5.5.6.

9.3.4 Where a generator is used as the emergency source of electrical power, it shall be:

.1 driven by an internal combustion engine (refer to 2.2.5, Part IX "Machinery");

.2 automatically started upon failure of the electrical supply from the main source of electrical power monitored at the emergency switchboard busbars and automatically connected to the emergency switchboard, and consumers stipulated under 9.3.1 shall be automatically supplied by the emergency generator. The total time of starting and load take-over by the generator shall not exceed 45 s;

.3 in case the automatic start of emergency unit stipulated by 9.3.4.2 shall not take place within 45 s, an emergency transitional source of electrical power shall be provided, which shall start immediately on failure of the main source of electrical power.

9.3.5 Where an accumulator battery is used as the emergency source of electrical power, it shall:

.1 operate without recharging with voltage variations across the terminals within 12 % of rated voltage during the whole discharge period, where voltage variations across the terminals of accumulator battery connected to an electronic voltage converter are determined by the permissible range of voltage variation across the terminals of the converter;

.2 be automatically connected to emergency distribution board busbars in case of failure of the main source of electrical power and supply at least the consumers mentioned under 9.3.7 during the time stipulated by 9.3.1 excepting electric drives of fire doors with their indicators and alarms, which can be supplied during 30 min.

9.3.6 As transitional emergency source of electrical power stipulated by 9.3.4.3, an accumulator battery shall be used, which shall operate without recharging with

voltage variations across the terminals within 12 % of rated voltage during the whole discharge period. Voltage variations across the terminals of accumulator battery connected to an electronic voltage converter are determined by the permissible range of voltage variation across the terminals of the converter, which shall not be above values specified in 2.1.3.1.

9.3.7 The capacity of the battery serving as the transitional source of electrical power shall be sufficient to supply, during 30 min, the following consumers:

.1 lighting and essential navigating lights according to 9.3.1.1, 9.3.1.2 and 9.3.2;

.2 all internal communications and announcing systems required in an emergency;

.3 general alarm system, fire detection and alarm system and warning system on starting a smothering fire-extinguishing system;

.4 daylight signalling lamps, sound signal means (whistles, gongs, etc.);

.5 command broadcast apparatus in accordance with item 11 of Table 2.3.4, Part IV "Radio Equipment" of the Rules for the Equipment of Sea-Going Ships;

.6 closing gear of watertight doors, their position indicators and signals warning of their closure;

.7 ship's security alarm system required by Part IV "Radio Equipment", as well as AIS installation and long-range identification and tracking system equipment, as required by Part V "Navigational Equipment" of the Rules for the Equipment of Sea-Going Ships.

Services listed under 9.3.7.2 to 9.3.7.7 may not be supplied from the transitional source if they have their own accumulator batteries, by which they are supplied during the required period of time.

9.3.8 For Class INF2 and Class INF3 ships, in accordance with the classification given in 7.3.2, Part VI "Fire Protection", regardless of the navigation area and tonnage of the ships, the emergency source of electrical power shall supply the services listed in 7.3.6 and 7.3.8, Part VI "Fire Protection" for a period of 36 hours and 9.3.1 of this Part.

9.4 DISTRIBUTION OF ELECTRICAL POWER FROM EMERGENCY SOURCES

9.4.1 Under normal service conditions, emergency distribution board shall be supplied from the main distribution board. The supply feeder shall have an overload and short-circuit protection fitted at the main distribution board.

At the emergency distribution board, a switch shall be provided, which shall switch off automatically in the case of de-energizing the busbars of the main distribution board.

Where the main distribution board shall be supplied from the emergency distribution board, the

automatic switch at the emergency distribution board shall be provided with short-circuit protection at least.

9.4.2 The emergency generator, during the stay of the ship in port, may be used to supply non-emergency consumers (refer also to 2.2.6, Part IX "Machinery"). In doing so, the following conditions shall be met:

provision is made for automatic disconnection of non-emergency consumers from the emergency distribution board to prevent overloading of the generator and to ensure the supply of emergency consumers;

damage of any control, protection and alarm circuits intended to maintain operation of the emergency generator during the stay of the ship in port, shall not affect the work of the main and emergency electrical power sources;

arrangements are provided to select the operating modes of emergency generators with a quick change-over to emergency mode being possible;

provision is made for instructions to be available onboard, for bringing all the controls (valves, switches, etc) in a position ensuring independent operation of the emergency generator when the ship is underway, and also containing information on the required oil fuel capacity, on the position of the operating mode switch (if any), on the position of ventilation closures, etc.

9.4.3 Consumers listed under 9.3.1 and 19.1.2 shall be supplied through separate feeders from the busbars of the emergency distribution board fitted up with relevant switch gear and protection. Supply of consumers mentioned under 9.3.1.2 to 9.3.1.6 and 19.1.2.1.2 to 19.1.2.1.6 may be effected from the main control console in the wheelhouse, which is supplied in conformity with 4.5.2.

9.4.4 Where a transitional source of power is available, consumers listed under 9.3.7 and 19.1.2.7 shall be supplied through a special distribution board on the feeders, of which no switches shall be fitted.

9.5 STARTING ARRANGEMENTS FOR EMERGENCY DIESEL GENERATORS

9.5.1 The following arrangements may be used as starting arrangements for emergency diesel generators:

.1 electric starter with its own accumulator battery and charging device;

.2 compressed air system with its own independent air receiver;

.3 hydraulic starting system;

.4 manual starting arrangements: starting handle for manual cranking, inertia starters, manually charged hydraulic accumulators or powder charge cartridges.

9.5.2 Each emergency generating set arranged to be automatically started shall be equipped with a starting device of an approved type with a stored energy capability of at least three consecutive starts. The source of stored energy shall be protected to preclude critical depletion by the automatic starting system, unless a second independent means of starting is provided. In addition, a second source of energy shall be provided for additional three starts within 30 minutes unless manual starting can be demonstrated to be effective.

9.5.3 Where automatic starting of the emergency diesel generator is not required, manual starting is permissible with the use of one of the starting arrangements specified in 9.5.1.4.

When manual starting is not practicable, the starting arrangements shall comply with the requirements of 9.5.2.

9.5.4 The starting arrangements of the accumulator batteries and the electric drives of the machinery ensuring the functioning of the compressed air or hydraulic systems of the emergency diesel generator starting shall be supplied from the emergency switchboard by separate feeders.

9.6 ALARM SYSTEM AND PROTECTION OF EMERGENCY DIESEL GENERATOR DRIVES

9.6.1 Emergency diesel generator drives having power of 220 kW and above shall be equipped with a protective device ensuring the shutdown of the engine in case of overspeed.

9.6.2 All protective devices that may influence the shutdown of emergency diesel generator drives, except for those preventing overspeed, shall be automatically overridden when the emergency diesel generator is in remote control or automatic mode during navigation. This requirement covers all emergency diesel generators regardless of their drives' output.

9.6.3 In addition to the remote fuel stop control, a local means of emergency shutdown of emergency diesel generator drives shall be provided.

9.6.4 For emergency diesel generator drives alarm system shall be activated at:

- fuel oil leakage from high pressure pipes;
- lubricating oil pressure below the minimum permissible value;
- high temperature of cooling water or cooling air.

9.6.5 For drives having power of 220 kW and above, in addition, provision shall be made for alarm system activating at:

- high lubricating oil temperature;
- pressure or flow of cooling water below the minimum permissible value;
- overspeed.

9.6.6 For drives having power of more than 2250 kW or with cylinder bore of more than 300 mm, in addition, provision shall be made for alarm system activating at excess of the oil mist concentration in crankcase.

9.6.7 Alarm system shall comply with the requirements given in 2.4.1, Part XV "Automation".

9.6.8 Grouped alarms shall be arranged on the navigation bridge.

9.6.9 Proceeding from the power of drives, local indication of the parameters listed in 9.6.4 to 9.6.6 shall be provided (within the same space as the emergency diesel generator) independent of the alarm and safety systems.

9.7 UNINTERRUPTIBLE POWER SYSTEM (UPS)

9.7.1 Uninterruptible power system (UPS), in addition to the requirements set forth below, shall comply with the requirements of IEC 62040 and applicable requirements of national standards.

9.7.2 UPS complying with these requirements may be used as emergency or transitional sources of electrical power as required by the present Part.

9.7.3 UPS type selection shall be appropriate to power supply requirements of the connected load equipment.

9.7.4 UPS shall be provided with a bypass, which ensures power supply to connected load from the ship's mains if the inverter fails.

9.7.5 Each UPS shall be provided with audible and visual alarm to be given for:

- .1 power supply failure to the connected load;
- .2 earth fault;
- .3 operation of battery protective device;
- .4 when the battery is being discharged; and
- .5 when the bypass is in operation for on-line UPS.

9.7.6 The requirements for location of the UPS shall be similar to the requirements for the location of the emergency or transitional source of electrical power.

9.7.7 UPS utilising sealed batteries may be located in any space other than the accommodation space, provided sufficient ventilation is ensured in the space.

9.7.8 UPS shall maintain rated voltage and frequency on the load side throughout the whole time necessary to supply the connected services.

9.7.9 On voltage recovery in the power supply circuit, the capacity of the UPS rectifier shall be sufficient to maintain rated voltage and frequency on the load side with simultaneous recharging the battery by the maximum possible charging current.

9.7.10 The accelerated (boost) charging of the UPS batteries by the maximum possible charging current shall be interlocked with the ventilation of the space where the UPS batteries are installed.

10 ELECTRICAL MACHINES

10.1 GENERAL

10.1.1 The materials of propulsion motors shafts, generators and slip coupling built into the shafting shall comply with the requirements of 3.7, Part XIII "Materials".

10.1.2 Alternating-current generators together with voltage correctors shall be capable to sustain, under steady short-circuit conditions, at least three-times the rated current within 2 s.

10.1.3 Electric propulsion generators and electric propulsion motors, or, where justified, also machines of different designation, shall have heating arrangements to maintain their temperature at least 3 °C above the ambient air temperature.

10.1.4 Generators built into the shafting of the main machinery shall have split stators and bearing shields if, due to the shaft arrangement, the stator displacement in the direction of the shaft from the rotor is not possible. Such generators shall have an air gap preventing mechanical contact of the rotor and stator under the most unfavourable service conditions.

10.1.5 Rotors and armatures of alternating and direct-current machines shall be capable of withstanding for 2 min, without damage and permanent set, the following increased speeds of rotation:

.1 generators, rotating converters and electric slip coupling and brakes: 120 % of the rated speed, but at least by 3 % more than the maximum speed transient process;

.2 series-wound motors: 120 % of the maximum permissible speed as indicated on the rating plate, but not less than 150 % of the rated speed;

.3 all motors other than mentioned above, 120 % of the maximum no-load speed.

10.1.6 Where a machine is so designed that after installation on board the ship its bottom portion is positioned below floor level, ventilation air intake shall not be through the bottom part of the machine.

10.1.7 Application of external cooling fans is not recommended for machines intended for installation on weather decks.

10.1.8 The power of electric motors supplied from an electrical power source, which does not comply with the requirements of 2.2.1.3, shall be calculated taking into account the additional heating due to the higher harmonic components.

10.2 SLIP RINGS, COMMUTATORS AND BRUSHES

10.2.1 Direct-current machines for driving the propulsion plants and direct-current machines rated at 200 kW and over shall be provided with sight holes to enable observation of the commutator and brushes without removing the lids.

10.2.2 The permissible wear of commutator segments or slip rings shall be indicated on their sides. It shall be taken equal to at least 20 per cent of the commutator segment or slip ring height.

10.2.3 For armatures more than 1000 kg in mass provision shall be made to allow reconditioning of the commutator without removing the armature from the machine.

10.2.4 A flexible copper conductor shall be used for drawing current from brushes. Brush holder springs shall not be used for this purpose.

10.2.5 The position of brushes in direct-current machines shall be clearly and indelibly marked.

10.2.6 Commutator type machines shall be capable of operating practically without sparking at any load from zero to rated value. No sparking shall be possible at the specified overloads, reversals or startups, to such an extent as to cause damage to brushes or commutators.

10.3 BEARINGS

10.3.1 Bearings shall be so designed as to avoid the possibility of oil splashing or leaking along the shaft and coming into contact with the machine windings or live parts.

10.3.2 The casing of the sliding bearing shall be fitted with a hole for excessive lubricating oil drain and with a lid in the upper part of the casing. Oil level indicators shall be provided on machines rated at 100 kW or more.

10.3.3 Pressure lubrication system shall incorporate pressure indicators for oil entering the bearing.

10.3.4 In electric propulsion machinery, or machines of different designation, where so justified, provisions shall be made to prevent flow of shaft currents through sliding friction bearings.

10.3.5 Generators driven by belts or chains from the main machinery of the ship shall be so designed that the effect of the lateral forces is taken into account.

10.4 TEMPERATURE DETECTORS

10.4.1 Stators of alternating-current machines rated at over 5000 kW, or having a core length of more than 1 m, shall be provided with temperature detectors installed where the machine may be expected to develop the highest temperatures.

10.4.2 Embedded temperature detectors are recommended for electric motors with short-time or intermittent operating conditions.

10.4.3 It is recommended that overload protection for windlass-driving electric motors shall be by means of embedded temperature detectors so selected that the protection device will disconnect the motor when the temperature rise limit for the insulation employed is exceeded by more than 30 %.

The terminals of the detector shall be located so as to be easily accessible.

10.5 OVERCURRENT

10.5.1 Generators shall be so designed that after reaching the steady-state temperature corresponding to the rated load they shall be capable of sustaining overcurrent as specified in Table 10.5.1.

Table 10.5.1

Type of generator	Overcurrent, %	Duration of overload, s
a.c.	50	120
d.c.	50	15

10.5.2 Electric motors shall be so designed that they are capable of developing, without stopping or sudden rotation frequency changes, the increased torque specified in Table 10.5.2.

10.5.3 For electric propulsion motors overload in torque and duration of overload are defined by the ship's designer taking into account changes in the main electric propulsion plant loads during maneu-

vering, sea passage, including navigation in difficult weather conditions etc.

10.6 ALTERNATING-CURRENT GENERATORS

10.6.1 General.

10.6.1.1 Each alternating-current generator shall have a separate, independent automatic voltage regulation system.

10.6.1.2 Alternating current generators shall possess sufficient excitation capacity to maintain the rated voltage with an accuracy of 10 % for 2 min at generator overcurrent equal to 150 % of the rated value and at a power factor 0,6.

10.6.1.3 Protection of alternating-current generators shall comply with the requirements of 8.2.

10.6.2 Voltage regulation systems.

10.6.2.1 Alternating-current generators shall have automatic voltage regulation systems ensuring that the voltage may be maintained within (2,5 % of the rated value (up to 3,5 % for emergency generators) at all load changes from no-load to rated load values at the rated power factor. The speed in this case shall be within the range specified in 2.11.3, Part IX "Machinery".

10.6.2.2 A sudden change in the balanced load of a generator running at rated speed and rated voltage, under given current and power-factor conditions, shall not cause a drop of voltage below 85 % or a rise above 120 % of the rated value. After the completion of transient processes, the generator voltage shall be restored within not more than 1,5 s with a deviation from the rated value being ± 3 %. For emergency sets these values may be increased, respectively, to 5 s and ± 4 % of the rated voltage.

Where no precise data are available on peak values of sudden load that may be connected additionally to the existing generator load, these may be taken equal to a load of 60 % of the rated current at a power factor of 0,4 or less, which is

Table 10.5.2

Nos	Type of motor	Overload in torque, %	Duration of overload, s	Testing conditions
1	Synchronous motors, as well as squirrel-cage motors with starting current not less than 4,5 times the rated current	50	15	Frequency, voltage and excitation to be maintained at rated levels
2	Induction motors for continuous and intermittent duties	60	15	Frequency and voltage to be maintained at rated levels
3	Motors as specified in item 2, but for short-time and continuous duty with varying load	100	15	Frequency and voltage to be maintained at rated levels
4	Direct-current motors	50	15	Voltage to be maintained at rated level

connected at idle speed and then disconnected. The speed in this case shall be within the range specified in 2.11.3, Part IX "Machinery".

10.6.2.3 For alternating-current generators the deviation from sine voltage shall not be more than 5 % of the harmonic component peak value.

10.7 DIRECT-CURRENT GENERATORS

10.7.1 General.

10.7.1.1 Compound-wound and shunt-wound direct-current generators shall be equipped with automatic voltage regulation systems.

10.7.1.2 Protection of direct-current generators shall comply with the requirements of 8.2.

10.7.2 Voltage regulations.

10.7.2.1 Voltage regulators of direct-current compound-wound generators shall enable reduction of no-load voltage, with the generator cold, by not less than 10 % below the rated generator voltage, taking into account the increased revolutions of the prime mover running at no load.

10.7.2.2 Manual voltage regulators shall be so designed that the voltage increases when their controls are rotated clockwise.

10.7.2.3 Voltage regulators of direct-current shunt-wound generators shall be so designed that, when the field current is removed, the field winding shall be closed to the discharge circuit.

10.7.2.4 Direct-current compound-wound generators shall have independent devices for voltage regulation within a tolerance of ± 1 % for generators rated at up to 100 kW, or within $\pm 0,5$ % for generators of rating exceeding 100 kW. The above regulation limits shall be maintained with the generator cold and hot and at any load within the operating load range of generators.

10.7.2.5 Direct-current sets comprising compound-wound generators shall have such external characteristics that the voltage of a hot generator adjusted to the rated value with an accuracy of ± 1 % at 20 % of the load does not vary at full load by more than $\pm 1,5$ % for generators rated at 50 kW or over, and by more than $\pm 2,5$ % for generators of lower output.

Voltage variations in a compound-wound generator running at 20 to 100 % of the rated load shall not exceed the following limits:

- .1 ± 3 % for generators rated at 50 kW and more;
- .2 ± 4 % for generators rated over 15 kW but less than 50 kW;
- .3 ± 5 % for generators rated at 15 kW and less.

10.7.2.6 Direct-current sets comprising shunt-wound generators shall have such external generator characteristics and automatic voltage regulators that voltage is maintained to within $\pm 2,5$ per cent of the rated value at all load variations from zero to the rated load.

10.8 ELECTROMAGNETIC BRAKES

10.8.1 The brake shall operate when the brake operating coil becomes de-energized.

10.8.2 A 30 % voltage drop below the rated value shall not cause a hot brake to operate.

10.8.3 Electromagnetic brakes shall allow of manual release.

10.8.4 Electromagnetic brakes shall be fitted with at least two pressure springs.

10.8.5 The shunt windings of a compound-wound electromagnetic brake shall be capable of holding off the brake even when no current flows through the series winding.

10.8.6 The shunt windings of electromagnetic brakes shall be so constructed or protected that they can be safe from damage at overvoltages such as occur when they are being disconnected (refer also to 5.4.3).

10.9 ASYNCHRONOUS ELECTRIC MOTORS SUPPLIED FROM FREQUENCY CONVERTERS

10.9.1 Asynchronous electric motors supplied from frequency converters shall have output reserve in order to prevent overheat caused by the voltage curve harmonic distortion.

10.9.2 Stator winding of asynchronous electric motors less than 100 kW supplied from frequency converters shall be two-layer winding or single layer with equal length of conductors with F- or H- class reinforced insulation.

10.9.3 In order to reduce overvoltage in stator winding of asynchronous motors supplied from frequency converters with the pulse-width modulation (PWM) it is necessary to:

- .1 apply star phase splicing of stator winding;
- .2 optimum selection of impedance of the electric motor stator winding and cable between electric motor and frequency convertor;
- .3 use control algorithm for frequency convertor limiting minimum pulse duration and pause between impulses.

11 TRANSFORMERS

11.1 GENERAL

11.1.1 The requirements of the Section apply to transformers listed in 3.3.

For additional requirements for transformers with voltages over 1000 V, refer to 18.4.

11.1.2 Dry-type transformers shall be used in ships.

11.1.3 Transformers shall have electrically separated windings for primary and secondary voltages.

11.2 OVERLOAD, VOLTAGE VARIATION AND OPERATION IN PARALLEL

11.2.1 Transformers shall be so designed as to be capable of withstanding 10 % overload for 1 hour and 50 % overload for 5 min.

11.2.2 For single-phase and three-phase transformers used to supply the ship's mains, voltage variation at an active load between zero and rated load shall not exceed 5 % for transformers rated at up to 6,3 kVA per phase and 2,5 % for transformers of higher rating.

11.2.3 Transformers intended to operate in parallel shall have their winding connections grouped together, their transformation ratios shall be the same, and their short circuit voltages shall be such that the load on any transformer does not depart from the corresponding proportional part of power output of each transformer by more than 10 % of the rated current for a given transformer.

11.2.4 Nominal capacities of transformers for parallel work shall not differ from each other more than twice.

12 POWER SEMICONDUCTOR UNITS

12.1 GENERAL

12.1.1 In power semiconductor units use shall be made of semiconductor elements of silicone type.

12.1.2 To prevent condensation in semiconductor units having the dissipation power above 500 W, provision shall be made for heating so that their temperature is at least by 3 °C higher than that of the ambient air.

12.1.3 Power semiconductor units shall be provided with air cooling (natural or artificial).

12.1.4 For power semiconductor units with forced cooling, provision shall be made for the protection reducing or disconnecting the load in case of inadequate cooling.

The activation of protection shall be preceded by the activation of light and sound alarms for exceeding the maximum permissible temperature of cooling medium at the system outlet.

12.2 PERMISSIBLE PARAMETERS OF VOLTAGE DISTORTION

12.2.1 The voltage curve harmonic distortion factor for the ship mains depending upon the operation of the power semiconductor units shall not exceed 10 %.

The voltage curve harmonic distortion factor shall be determined by the formula given in 2.2.1.3.

12.2.2 The factor of maximum relative deviation of instantaneous voltage value from the first harmonic component shall not exceed 30 %.

Factor K_{MD} shall be determined by the formula

$$K_{MD} = \frac{U_m - U_{1m}}{U_{1m}} 100 \% \quad (12.2.2)$$

where U_m = peak value of the ship mains voltage;
 U_{1m} = peak value of the first harmonic component.

12.3 CONTROL AND SIGNALLING SYSTEMS

12.3.1 Semiconductor arrangements shall be provided with light signals for connection or disconnection of power circuits and control circuits.

12.3.2 The power section of semiconductor arrangements shall be electrically insulated from the control system.

12.3.3 The long-term current deviation in the parallel branches of semiconductor arrangements shall not exceed 10 % of average current value.

12.3.4 The operation of semiconductor arrangements shall not be hampered by the failure of particular gates. Where the load upon particular gates exceeds permissible values, it shall be reduced automatically.

When a gate fails, light and sound signals shall be activated.

12.4 MEASURING INSTRUMENTS

12.4.1 Semiconductor arrangements shall be fitted up with measuring instruments in accordance with their purpose.

12.4.2 In the scales of measuring instruments of semiconductor arrangements, maximum permissible parameter values shall be marked off. Where forced cooling is applied, the maximum permissible temperature shall be marked off clearly in the scale of the instrument for measuring the cooling air temperature.

13 ACCUMULATOR BATTERIES

13.1 GENERAL

13.1.1 Accumulator batteries shall be so constructed that the loss of capacity of a fully charged battery due to self-discharge after 28 days out of operation at a temperature of $(25 \pm 5)^\circ\text{C}$ does not exceed 30 % of rated capacity for acid batteries and 25 % for alkaline batteries.

13.1.2 Battery containers and closures for holes shall be so constructed and secured as to prevent spilling or splashing of the electrolyte when the container is inclined on any side to an angle of 40° from the vertical.

Closures shall be made from durable material resistant to electrolyte. Closure design shall be such as to avoid building up of excess gas pressure inside the battery.

13.1.3 The mastics used shall not change their properties or deteriorate at ambient temperature changes within -30 to $+60^\circ\text{C}$.

13.1.4 Materials used for fabrication of crates to house battery cells shall be resistant to electrolyte. Individual cells arranged within the crates shall be so secured that it is impossible for them to move relative to one another.

13.1.5 Where batteries are fitted for use for essential and emergency services a schedule of such batteries shall be compiled and maintained. The schedule, which shall be reviewed by the Register, shall include the following information regarding the battery:

- type and manufacturer;
- voltage and capacity;
- location;
- equipment and systems served;
- maintenance/replacement cycle dates;
- date of last maintenance or replacement;
- for replacement batteries in storage, the date of permissible shelf life.

Details of the schedule shall be included in the ship's safety management system specified in Chapter IX of SOLAS-74.

13.1.6 Where batteries are replaced, they shall be of an equivalent performance type, which shall be reflected in appropriate instructions.

13.1.7 Where vented type battery replace valve-regulated sealed type at its location, the requirements of the Rules relevant to the location and ventilation of the batteries shall be met.

13.2 ARRANGEMENT OF ACCUMULATOR BATTERIES

13.2.1 Batteries having a voltage in excess of the safety voltage, as well as batteries having a capacity over 2 kW computed from the maximum charging current and the rated voltage, shall be located in special battery compartments accessible from the deck, or in appropriate boxes installed on deck. These spaces shall be special electrical spaces.

Batteries having a charge capacity of 0,2 kW up to 2 kW may be installed in boxes or cabinets located inside the ship's hull.

In ships with low-power electrical installation, except passenger ships, the above batteries may be installed in the machinery space in such a way that their upper section is at least above the margin line in case the ship is flooded.

Accumulator batteries intended for the electric starting of internal combustion engines except for emergency units may be installed in machinery spaces in special cabinets with sufficient ventilation.

Batteries having a charge capacity less than 0,2 kW and unattended batteries giving off no gases in operation are allowed to be installed in any space, other than accommodation spaces, provided they are protected from the action of water and mechanical damage and do not harmfully affect the surrounding equipment.

13.2.2 The acid and alkaline batteries shall not be placed in one compartment or in one box. The vessels and instruments intended for the batteries with different electrolytes shall be placed separately.

13.2.3 The inside part of a battery compartment or cabinet, as well as all structural parts, which may be subjected to harmful effects of electrolyte or gas, shall be suitably protected.

13.2.4 Accumulator batteries and individual cells shall be properly fixed in position. In case they are installed on shelves in two or more rows, all the shelves shall have a clearance of at least 50 mm on the face and back side for air circulation, and the distance from the deck to the plugs in the upper row of cells shall not exceed 1500 mm.

13.2.5 When installing the accumulator batteries or individual accumulators (cells), provision shall be made for fitting linings and spacers between them that will ensure a clearance for circulation of air of not less than 15 mm on all sides.

13.2.6 Warning notices indicating the danger of explosion shall be provided on the doors leading to the battery compartment or nearby, as well as on the boxes containing the accumulators.

13.3 HEATING

13.3.1 The battery compartments and boxes where-in temperature in operation may fall down below +5 °C shall be heated. The heating is allowed to be effected by the heat produced in adjacent spaces, as well as with water or steam radiators located inside the battery rooms (also refer to 2.9.3.3).

13.3.2 The heating system valves shall be located outside the battery compartments.

13.3.3 The shipboard air conditioning system shall not be used for heating the battery compartments.

13.4 VENTILATION

13.4.1 The battery compartments and boxes, except for unattended batteries not releasing gases during operation, shall have sufficient ventilation that will prevent accumulation of explosive air-gas mixture.

The ventilation system shall meet the requirements of 12.10, Part VIII "Systems and Piping".

13.4.2 The battery compartments equipped with mechanical ventilation shall be provided with devices that will prevent charging of accumulator batteries before ventilation has been switched on.

Charging cycle shall be automatically discontinued, shall the ventilators stop.

13.5 CHARGING OF ACCUMULATOR BATTERIES

13.5.1 Provision shall be made for charging facilities to charge the accumulator batteries of essential services within 8 h.

In case an additional battery is used substituting that being charged, the charging time may exceed 8 h.

13.5.2 The charging facilities shall have means for measuring the voltage across battery terminals and charging current, as well as discharging current for emergency sources of electrical power.

13.5.3 In ships equipped with portable accumulator-fed lanterns or with spare accumulator-fed navigation lanterns the facilities shall be provided for charging the accumulators of these lanterns.

13.6 INSTALLATION OF ELECTRICAL EQUIPMENT IN BATTERY COMPARTMENTS

13.6.1 Apart from safe-type lighting fixtures and cables led to accumulators and lighting fixtures, no other electrical equipment shall be installed in battery compartments.

Cables led to accumulator batteries and lighting fixtures may run openly, provided they have metal armour or braid covered with non-metal sheath and this metal armour or braid is reliably earthed at both ends.

13.7 ELECTRICAL STARTERS FOR INTERNAL COMBUSTION ENGINES**13.7.1 Number of starter accumulator batteries.**

13.7.1.1 In a ship equipped with electrically-started internal combustion engines, irrespective of the number of such engines, not less than two starter batteries shall be permanently installed for starting each of the main and auxiliary engines, or not less than two common batteries for starting all the engines. Moreover, provision shall be made for a permanent switching system that will ensure possible use of any battery for starting any of the engines in the group serviced by this battery. In this case parallel connection of the batteries is not allowed.

13.7.1.2 For ships of restricted area of navigation **R3** and also for ships of restricted area of navigation **R2** with the electrical installation of low power (other than passenger ships), it is permitted to have only one starter accumulator battery, provided that it may be used for starting all the engines.

13.7.2 Battery characteristics.

13.7.2.1 Each starter battery shall be designed to withstand the discharging current in starter duty that will correspond to the maximum current through the most powerful starting electric motor.

13.7.2.2 Capacity of each battery shall be sufficient for six starts of the engine in the ready-for-start condition, or in case of two or more engines, for not less than three starts of each engine. Total capacity of the batteries for starting main engines shall provide the required number of starts during 30 min.

13.7.2.3 In computing battery capacity, the duration of each start shall be considered not less than 5 s.

13.7.3 Charging facilities.

13.7.3.1 A starter battery charging facility shall be supplied by a separate feeder from the main switchboard even if the battery is charged from the appurtenant generator.

13.7.3.2 For ships of restricted area of navigation **R3** and also for ships of restricted area of navigation **R2** with the electrical installation of low power (other than passenger ships) the starter battery may be charged only from the appurtenant generator.

14 ELECTRICAL APPARATUS AND ACCESSORIES

14.1 Electrical apparatus

14.1.1 General.

14.1.1.1 The design of switchgear with renewable contacts shall be such that renewal of contacts shall be possible by means of standard tools, without dismantling the switchgear or its basic components.

14.1.1.2 All switches, circuit breakers and isolating switches, except those for cabins, shall be provided with mechanical or electrical contact-making position indicators located where the apparatus is actuated by the operator.

14.1.1.3 The positions of controller and master controller drums shall be rigidly locked by mechanical means, location in zero position being more rigid than elsewhere.

Controller and master controlled drums shall be fitted with a scale and an indicator of position.

14.1.1.4 Machine control gear, except such as is used for smooth regulation, shall be so constructed that the end and intermediate fixed positions are easy to feel at various control stages while movement beyond the end positions shall be impossible.

14.1.2 Electrical switch apparatus and protective devices.

14.1.2.1 Electrical switch apparatus shall comply at least with the national standards and shall be so selected that:

under normal operation mode their rated voltages, currents and permissible temperatures are not exceeded;

they are capable of withstanding, without damage and heating above the limiting temperature, the prescribed overloads as specified for transient modes;

their characteristics under short-circuit current mode correspond to the prospective short-circuit current values at the outputs (terminals) of each switch apparatus at the design value of the power factor.

14.1.2.2 The nominal breaking capacity (I_{cn}) of electrical switch apparatus designed to break short-circuit currents shall be not less than:

actual value of the periodic component of the prospective short-circuit current for alternating current (I_{ac});

the prospective short-circuit current at the specified time constant of the direct current apparatus at the place of their installation at disconnection.

14.1.2.3 The nominal making capacity (I_{cm}) of electric switch apparatus, which may be incorporated in a shorted electric circuit, shall be not less than the peak prospective short-circuit current (I_p) at the place of their installation.

14.1.2.4 The electrodynamic strength current of electric switch apparatus not intended for interrupting short-circuit currents shall be not less than the peak prospective short-circuit current at the place of their installation.

14.1.2.5 Thermal strength of electric switch apparatus under short-circuit condition shall be consistent with the thermal action of periodic component of the prospective short-circuit current (root-mean square (r.m.s.)) (I_{ac}) at the place of their installation during short-circuit specified by the selective action of protective devices.

Note. Thermal strength of electric switch apparatus is determined as the product of squared r.m.s. value of the periodic component prospective short-circuit current, kA, by the time, s, $I^2 \times t$ and shall be indicated in its technical specifications.

14.1.2.6 Rated short-time withstand current (I_{cw}) for electric switch apparatus in circuits with selective action of protective devices shall be not less than the r.m.s. periodic component of the prospective short-circuit current at the first half-cycle ($I_{cw} > I_{ac}$).

14.1.2.7 The use of a circuit-breaker with inadequate rated service ultimate breaking capacity (I_{cs}) and rated ultimate making capacity (I_{cm}) corresponding to the prospective short-circuit current at the place of its installation is allowed, provided it is protected on the generator side by means of fuses and/or a circuit-breaker with at least necessary ratings for short-circuit currents, which is not used as a generator automatic switching device.

Such protective devices having only rated ultimate breaking capacity (I_{cu}) shall not be installed on the main and emergency switchboards and shall not be applied in the circuits of essential and emergency consumers. Their characteristics shall be such that:

.1 while breaking the maximum prospective short-circuit current, the circuit breaker on the load side be not damaged to become unfit for further service;

.2 switching the circuit breaker on the prospective maximum current does not result in damage to the remaining part of the electrical installation; while it is allowed for the circuit breaker on the load side not to be immediately fit for further operation.

14.1.2.8 In electric circuits with a rated load current in excess of 320 A circuit breakers shall be fitted for overload protection. The use of circuit breakers is recommended at the current exceeding 200 A.

14.1.2.9 In direct current compound generator circuits where the generators are intended for parallel operation, circuit breakers shall have a pole for a common-wire mated mechanically with the other

poles of the circuit breaker to switch it on before the other poles are connected to busbars and to switch it off after their disconnection.

14.1.3 Manually operated controls.

14.1.3.1 The direction of movement of manually operated controls of switchgear or machine control gear shall be such that clockwise rotation of a handle (lever) corresponds to closing of an apparatus, start-up of a motor, increased speed, increased voltage, and so forth.

Where lifting or lowering mechanisms are under control, clockwise rotation of a handle (handwheel) or shifting of a handle (lever) toward the operator shall correspond to lifting movement, and counter-clockwise rotation or shifting away from the operator to lowering movement.

14.1.3.2 Switchgear push buttons shall be so designed that they cannot be actuated accidentally.

14.1.4 Motor-operated gear.

14.1.4.1 Actuators of switches and circuit breakers shall be so designed that in the event of loss of supply to the actuating motor the switch or circuit breaker contacts remain in closed or in open position only.

14.1.4.2 Electric motor actuators shall provide for reliable closing of the apparatus at all changes of the control voltage within 85 to 110 % of the rated value and in case of alternating current at frequency deviation within ± 5 % of the rated frequency.

14.1.4.3 A drop of control voltage down to 70 % of the rated value shall not result in opening the apparatus contacts, or reducing the pressure thereof.

14.1.4.4 The design of a motor-actuated switchgear shall embody a provision for manual operation.

14.1.5 Coils.

14.1.5.1 A conductor or a shoe shall be attached to a coil winding so as to avoid the mechanical stresses of the connection affecting the coil turns. The tapping of voltage coils shall be made from flexible stranded conductor, except where the contact terminals are secured directly to the coil frame.

14.1.5.2 The coils of electromagnetic apparatus shall bear notations giving particulars of their characteristics.

14.1.6 Resistor elements.

14.1.6.1 Resistor elements shall be easily replaceable, in sections or in total.

14.1.6.2 Resistors shall be so disposed and ventilated that they do not heat other devices beyond the permissible limits.

14.1.6.3 The joints between resistor elements or between these and terminals shall be effected by welding or by mechanical press-fitting where there is no need to provide for their dismantling. Soldering is admissible where there is no risk of temperature rise at the point of junction above the limits specified for the solder.

14.1.7 Fuses.

Fuse link housing shall be of totally enclosed type and allow no arc ejection to the outside, or sparking, or any other harmful effect upon the adjacent parts in case the fuse blows.

14.2 ELECTRICAL ACCESSORIES

14.2.1 General.

14.2.1.1 The enclosures of accessories and fittings shall be constructed from materials of adequate mechanical strength, which are corrosion-resistant or adequately protected from corrosion and at least flame-retardant. The enclosures of accessories and fittings designed for installation on weather decks, in refrigerated cargo spaces, fish processing shops, or other humid areas shall be made of brass, bronze, or equivalent alloy, or from plastics of suitable quality. If steel or aluminium alloys are used, anti-corrosive protection shall be provided.

It is inadvisable to use threaded connections or tight-fit mating of parts in accessories and fittings made of aluminium alloys.

14.2.1.2 Insulating parts, to which current-carrying components are fixed, shall be made of materials that do not evolve gases as would ignite from an electric spark at a temperature up to and including 500 °C.

14.2.1.3 The lighting fixtures designed to be mounted on or close to combustible materials shall be so constructed as not to get heated over 90 °C.

14.2.2 Lampholders.

14.2.2.1 The design of lampholders fitted with screw caps shall be such as to effectively prevent the lamps from getting loose in service.

14.2.2.2 No switches are allowed to be fitted in lampholders.

14.2.2.3 Each lighting lampholder shall be marked to indicate rated voltage and allowable current or load.

14.2.3 Plug and socket connector.

14.2.3.1 The pin jacks of socket outlets shall be so constructed as to ensure permanent pressure in contact with the plug pins.

14.2.3.2 Plugs with slotted pins are not allowed for use. The pins of plugs designed for currents in excess of 10 A shall be cylindrically shaped, solid or hollow.

14.2.3.3 Socket outlets and plugs for voltages exceeding the safety level shall have contacts for connecting the earth continuity conductors of the incoming cables from current consumers.

14.2.3.4 Socket outlets having protective enclosures shall be so constructed that the required degree of protection is ensured regardless of whether the plug is in or out of the socket outlet.

14.2.3.5 Socket outlets rated at over 16 A shall be provided with built-in switches. Provision shall be also made for interlocking such socket outlets to prevent the possibility of the plug being inserted or withdrawn when the socket switch is in the "closed" position.

14.2.3.6 Where socket outlets are not interlocked, the clearance between contacts in air or across the insulation surface shall be such that no short circuit is possible due to arcing over when the plug is withdrawn while carrying a load 50 % above the rated current at rated voltage.

14.2.3.7 Socket outlets and plugs shall be so designed that it is not possible to insert only one live

contact pin into the socket outlet, or insert a live contact pin into the earthing contact. Besides, the design of the outlets intended for connecting the motors (gears), the direction of rotation (operation) of which depends on the change of the sequence of phases or poles connected, shall exclude the possibility of the sequence change. When the plug is inserted into the socket outlet, the earthing part of the plug shall make contact with the earthing part of the socket outlet before connecting the live pins.

14.2.3.8 In socket outlets, plugs and branched pin jacks, no fuses shall be fitted.

15 ELECTRICAL COOKING AND HEATING APPLIANCES

15.1 GENERAL

15.1.1 Only stationary-type electrical cooking and heating appliances are permitted for use.

15.1.2 Electrical cooking and heating appliances shall be supplied from the main switchboard or from distribution boards intended for this purpose.

15.1.3 The supporting structural parts of electrical cooking and heating appliances, as well as the internal surfaces of enclosures, shall be fabricated entirely from non-combustible materials.

15.1.4 In heated condition, permissible loss current shall not exceed 1 mA per 1 kW of rated power for a separately connected heating element or 10 mA for the appliance as a whole.

15.1.5 Electric cooking and heating appliances shall be so designed that the temperature of their components, which shall be handled by the personnel or which can be touched inadvertently, does not exceed the value indicated in Table 15.1.5.

Table 15.1.5

Nos	Item	Permissible temperatures, °C
1	Control handles and other parts to be handled during long periods of time	
	Metallic	55
2	Same, but where short-time contact is possible:	Non-metallic
		metallic
		non-metallic
3	Enclosures of electric space heating and cooking appliances at ambient temperature of 20 °C	80
4	Air coming out from electric space heating appliances into heated spaces	110

15.2 HEATING APPLIANCES

15.2.1 Electric heating appliances intended for space heating shall be of stationary type. These appliances shall be provided with devices for disconnection of the supply source when the temperature rise of the enclosure exceeds the permissible limit.

15.2.2 If built-in disconnecting devices are not provided in the heating and cooking appliances, such devices shall be installed in the rooms wherein these appliances are located.

Switches shall disconnect power supply at all poles or phases.

15.2.3 The enclosures of electric heating appliances shall be so constructed as to prevent the possibility of any objects being placed upon them.

15.2.4 Stationary heating appliances rated at 380 V and upwards and admitted for use in accordance with Table 4.2.3 shall be protected against access to live parts, except with the aid of special tools. The enclosures shall bear notices giving the voltage value.

15.2.5 Electric cooking appliances forming part of galley equipment shall be so constructed as to avoid the possibility of cooking utensils being brought into contact with live parts, and to prevent short circuits or damage to insulation due to liquid spilling or leakage.

15.2.6 Sauna shall be fitted with the temperature limiter, which shall cut off the electrical heater from the mains (at that, electrical heater control circuits shall also be de-energized), if the temperature in the area of 0,3 m from the ceiling exceeds 140 °C. In this area the electrical heater control devices (thermostats and temperature limiters) and associated cables withstanding a temperature not less than 170 °C may only be installed.

15.3 OIL, FUEL AND WATER HEATERS

15.3.1 In addition to the requirements of the Chapter, heaters shall meet the requirements of Section 6, Part X "Boilers, Heat Exchangers and Pressure Vessels".

15.3.2 Oil and fuel having a flash point above 60 °C may be heated by means of electric heaters, provided the requirements of 15.3.3 and 15.3.4 are fulfilled.

15.3.3 Electric heaters for pipelines shall be equipped with devices for temperature control, light signals for indication of operating conditions and also with light and sound signals for indication of fault conditions and inadmissible temperature rise.

15.3.4 Electric heaters for oil and fuel heating in tanks shall be equipped with devices for temperature control of the heated medium, temperature sensors for surfaces of heating coils, low level indicators and means for disconnection of power supply to the heaters in case the upper temperature limit or the lowest permissible level is exceeded.

15.3.5 Oil and fuel heaters shall be fitted up with devices for temperature control of the medium

heated. Irrespective of those devices, a manually disengaged device shall be provided for de-energizing the heaters as soon as their surface temperature reaches the value at least 15 °C lower than the flash point.

For self-regulating heaters protection may be omitted.

15.4 SYSTEMS UTILISING HEATING CABLES

15.4.1 Systems utilising heating cables for removing ice and avoiding icing shall be provided for ship's arrangements, equipment and spaces intended for:

performing by the ship its purpose (descriptive notation in the class notation);
 maintaining manoeuvrability;
 maintaining stability;
 safety of crew (rafts, boats, ladders, guard rails, etc.).

15.4.2 Heating capacity of such systems shall not be less than:

300 W/m² for the spaces of open decks, helidecks, ladders and gangways;

200 W/m² for superstructures;

50 W/m for guard rails with internal heating.

15.4.3 In the systems utilising electrical heating cables, particular attention shall be paid upon the heat transfer between the cable and the equipment (space) to be heated to provide efficient heating.

15.4.4 The switchboard for the said systems shall be equipped with:

wattmeter or amperemeter to indicate the total load;

name plate indicating the rated load of each circuit and the switchboard as a whole;

residual-current device for each circuit;

load signal lamps for each circuit.

15.4.5 The heating cables shall be protected against overload exceeding 125 % of the rated current of the circuit. For cables of self-regulating type the overload protection may be omitted.

15.4.6 The use of heating cables for heating of pipelines carrying combustible media, as well as for pipelines and valves located in dangerous rooms and spaces, is only allowed when fitted with the appropriate type of explosion protection proved by a competent body certificate.

16 CABLES AND WIRES

16.1 GENERAL

16.1.1 The requirements of this Section do not apply to radio frequency, telephone cables, and to power cables designed for voltages above 1000 V.

16.2 CABLE CONDUCTORS

16.2.1 Cables intended for supplying essential services shall have stranded conductors (refer also to 16.8.1.2). Table 16.2.1 specifies the minimum number of wires per conductor.

Table 16.2.1

Nominal cross-sectional area of conductor, mm ²	Minimum number of wires per conductor	
	circular non-tightened conductors	tightened sector and circular conductors
0,5 to 6	7	—
10 to 16	7	6
25 to 35	19	6
50 to 70	19	15
95	37	15
120 to 185	37	30
240 to 300	61	30

Note. The ratio between nominal diameters of any two wires in the mechanically tightened cable conductor shall not exceed 1:1,3, and for conductors formed geometrically, but not tightened, 1:1,8.

16.2.2 Connections of separate wires of the conductor shall be displaced from one another by not less than 500 mm along the length of the conductor.

Such connections shall not impair the mechanical and electrical properties of the wire nor change the cross-sectional area of wires or the conductor as a whole.

16.2.3 Separate wires of rubber-insulated copper conductors shall be tinned or coated with suitable alloys.

Tinning or other anticorrosive coating of external stranding or of all wires of a rubber-insulated core may be dispensed with, if the manufacturer takes steps to guarantee that the rubber insulation does not affect adversely the metal of the conductor.

No tinning is required for conductors provided with other types of insulation.

16.3 INSULATING MATERIALS

16.3.1 For conductors of cables and wires, insulating materials specified in Table 16.3.1 may be used.

Table 16.3.1

Type of insulating compound	Abbreviated designation	Maximum rated temperature during normal operation, °C ¹
Thermoplastic Polyvinyl chloride or copolymer of vinyl chloride and vinyl acetate	PVC	70
Elastomeric or thermoset Ethylene-propylene rubber or similar (EPM or EPDM)	EPR	90
Hard grade ethylene propylene rubber	HEPR	90
Cross-linked polyethylene	XLPE	90
Silicon rubber	S 95	95
Ethylene-propylene rubber or similar (EPM or EPDM) halogen-free	HF EPR	90
Hard grade halogen-free ethylene propylene rubber	HF HEPR	90
Halogen-free cross-linked polyethylene	HF XLPE	90
Halogen-free silicon rubber	HF S 95	95
Halogen-free cross-linked polyolefin	HF 90	90

¹Wire temperature for calculating the permissible continuous load of cable.

16.4 CABLE SHEATHING

16.4.1 Protective sheathing of cables and wires may be manufactured of non-metallic materials as specified in Table 16.4.1, lead, cooper.

Table 16.4.1

Type of non-metallic solid sheathing compound	Abbreviated designation	Temperature limit of the cable, °C
Thermoplastic Polyvinyl chloride or copolymer of vinylchloride and vinyl-acetate	ST 1	60
	ST 2	85
Halogen-free	SHF 1	85
Elastomeric or thermoset Polychloroprene rubber	SE 1	85
Chlorsulphonated polyethylene or chlorinated polyethylene rubber	SH	85
Halogen-free	SHF 2	85

16.4.2 Sheathing shall be of uniform thickness within allowable limits, throughout the manufacturing length of cable, and shall envelope the cable cores concentrically. The sheaths shall form an impervious covering in tight contact with the protected cores.

16.4.3 Lead cable sheaths shall be made of appropriate alloys specified by the national standards.

Pure lead sheaths may only be used when the lead sheath is covered with an additional protective envelope.

16.5 PROTECTIVE COVERINGS

16.5.1 Metal shielding braid shall be made of tinned copper wire. If plain copper wire is used, it shall be protected by suitable sheath. Non-shielding braids may be made of galvanized steel wires. The braid shall be uniform and its density shall be such that its mass is at least equal to 90 % of the mass of tube of equal diameter made of the same material and with a wall thickness equal to the braiding wire diameter.

16.5.2 Metal armour shall be made of annealed and galvanized steel wire or tape, wound helically, with a suitable pitch, over the cable sheath or an intermediate bedding over the sheath in such a way that a continuous cylindrical layer is formed to assure adequate protection and flexibility of the finished cable. On special demand, the armour may be made of non-magnetic metals, using the techniques described above.

16.5.3 Cable armour or braid made of steel tape or wire shall be effectively protected against corrosion.

16.5.4 Armour bedding shall be made of moisture-resistant materials.

16.6 MARKING

16.6.1 Rubber- or polyvinylchloride-insulated cables having a limiting temperature at core 60 °C shall be marked in such a manner as would enable their identification.

16.6.2 Cable cores shall be marked in such a manner as to assure adequate preservation of the markings.

In multi-core cables with cores arranged in several concentric layers at least two adjacent cores in each layer shall be marked with different colours.

16.6.3 Cables of fire resistant type shall be clearly marked.

16.7 HOOKUP WIRES

16.7.1 For internal wiring of distribution boards and electric devices, single-wire insulated conductors may be used (refer also to Table 16.3.1).

16.7.2 Non-insulated wires and busbars are permitted for use only for internal wiring of electrical devices. The external wiring with non-insulated wires or busbars is not allowed unless they are reliably guarded.

16.8 CABLING

16.8.1 General.

16.8.1.1 Use shall be made of flame-retarding or non-combustible cables and conductors with copper cores manufactured and tested in compliance with this Part of the Rules, national standards, as well as with the relevant requirements of IEC 60092-350, 60092-352, 60092-353, 60092-354, 60092-360, 60092-370, 60092-376.

Cables manufactured and tested in compliance with the standards other than those specified above shall be accepted provided they are in compliance with international or national standards and are of an equivalent or higher safety level than those.

Use of flexible or optical fibre cables used for special purposes may be allowed provided they are manufactured and tested according to the approved standards.

In this case, IEC 60331-23 for data transfer cables and IEC 60331-25 for optical fibre cables may be used.

As far as the fire resistance testing of cables is concerned, use shall be made of IEC 60331-1 for cables with outside diameter more than 20 mm and IEC 60331-21 or 60331-2 for other cables.

16.8.1.2 Cables and wires having stranded conductors shall be used, the cross-sectional area of the conductors being not less than:

.1 1,0 mm² for power, control and signalling circuits of essential services and for power circuits of other services;

.2 0,75 mm² for control and signalling circuits;

.3 0,5 mm² with the number of cores in the cable not less than four for instrumentation and internal communication circuits.

For power circuits supplying non-essential services, the use is permitted of cables with single-wire conductors having a cross-sectional area of 1,5 mm² and less.

16.8.1.3 In circuits with heavy inductive and capacitive loads, the use shall be made of cables designed for working voltages approximately equal to twice the rated voltage of the circuit.

16.8.1.4 Maximum permissible temperature for the insulating material of the cable cores or wires shall be at least 10 °C higher than the maximum specified ambient temperature.

16.8.1.5 In locations affected by the action of petroleum products or other aggressive medium, the use shall be made of cables having a sheath resistant to such medium. Cables not having such properties may be installed in such locations only fitted in metallic pipes (refer to 16.8.8).

16.8.1.6 In locations where cables may be subjected to mechanical damage, the use shall be made of cables having an appropriate armour, while other types of cables in such locations shall be

protected with special reliable covers or shall be installed in metallic pipes (refer to 16.8.8).

16.8.1.7 Cables supplying the electric drives of the sprinkler system and of the fire pump from the emergency source of electrical power and running through casings of machinery spaces of category A, galleys, drying rooms and other similar fire-hazardous spaces, shall be of fire-resisting type or protected from the action of flame.

The above requirements cover the remote-control cables of those devices as well.

16.8.1.8 Cables for services required for operations under fire conditions, including cables for their power supply (refer to 16.8.1.11) shall be routed clear of high fire risk spaces (refer to 16.8.1.9), and in addition to passenger ships, main vertical fire zones, except for cases, when the services themselves are installed in such spaces.

Where such installation of cables is necessary, the cables shall be of fire resistance type according to 16.8.1.1.

16.8.1.9 The high fire risk spaces include:
 machinery spaces of category A;
 spaces containing fuel treatment equipment and other highly flammable substances;
 galleys and pantries containing cooking appliances;
 laundries containing drying equipment;
 accommodation spaces of high fire risk;
 paint rooms, store rooms and similar spaces for storage of flammable liquids;
 enclosed and semi-enclosed spaces requiring installation of safe-type electrical equipment.

16.8.1.10 Cables, distribution gear, switch apparatus and protective devices associated with these

services shall be so designed or installed that the likelihood of the device failing in case of fire in any one such space or area is minimised.

16.8.1.11 Among the services required for operation under fire conditions are the following:

- general alarm;
- fire extinguishing systems;
- fire detection and alarm systems;
- warning alarm of fire extinguishing system release;
- controls of fire doors with door-position indicators;
- control of watertight doors with door-position indicators and warning alarm;
- emergency lighting;
- public address system;
- low-location lighting;
- remote emergency shutdown arrangements for systems, which operation may support the propagation of fire and/or explosion.

16.8.1.12 Use of fire resistant cables for devices listed in 16.8.1.11 is not mandatory provided that:

- .1 fail safe functioning of devices is provided by, at least, two-loop or radial laying of cables spaced apart as far as practical so that if one loop or radial section fails, the rest sustain operability of the devices;
- .2 the devices are provided with self-monitoring with such damages like a short circuit, an open-circuit fault, earth fault, or trouble-free functioning of these devices is ensured by duplicating cables laid in separate runs spaced apart as far as practical.

16.8.2 Choice of cables and wires for loads required.

16.8.2.1 Permissible continuous loads on single-core cables and wires with different insulation materials shall comply with the values specified in Table 16.8.2.1.

Table 16.8.2.1

Current ratings in continuous service of single-core cables and wires with different insulation materials for ambient temperatures of +45 °C

Nominal cross-sectional area of conductor, mm ²	Insulating material				
	Polyvinylchloride	Heat-resistant polyvinylchloride	Butyl rubber	Ethylene-propylene rubber of cross-linked polyethylene	Silicone rubber or mineral insulation
	Maximum permissible conductor operating temperature, °C				
	60	75	80	85	95
1	8	13	15	16	20
1,5	12	17	19	20	24
2,5	17	24	26	28	32
4	22	32	35	38	42
6	29	41	45	48	55
10	40	57	63	67	75
16	54	76	84	90	100
25	71	100	110	120	135
35	87	125	140	145	165
50	105	150	165	180	200
70	135	190	215	225	255
95	165	230	260	275	310
120	190	270	300	320	360
150	220	310	340	365	410
185	250	350	390	415	470
240	290	415	460	490	—
300	335	475	530	560	—

The current ratings given in the Table are applicable to the following cases of cable installation:

when installing not more than 6 cables in one bunch or in one row closely adhering to one another;
when installing cables in two rows, regardless of the number of cables in one row, on condition that a free space for air circulation is provided between each group or bunch of 6 cables.

When installing more than six cables in one bunch, which may be under rated current simultaneously or when no free space for air circulation between them is provided, the permissible current ratings for the given cross-sectional area shall be reduced by 15 % (factor 0,85).

16.8.2.2 Current ratings in amperes for cross-sectional areas given in Table 16.8.2.1 and also for any other cross-sectional areas shall be calculated from the formula

$$I = \alpha S^{0,625} \quad (16.8.2.2)$$

where α = factor corresponding to the maximum permissible service temperature of the conductor obtained from Table 16.8.2.2;

S = nominal cross-sectional area of conductor.

Table 16.8.2.2

Maximum permissible conductor operating temperature, °C	Factor α for nominal cross-sectional area S , mm ²	
	$\geq 2,5$	$\leq 2,5$
60	9,5	8
65	11	10
70	12	11,5
75	13,5	13
80	15	15
85	16	16
90	18	20

16.8.2.3 The permissible current ratings for double-, triple- and quadruple-core cables shall be determined by reducing the values given in Table 16.8.2.1 for the given cross-sectional area with the use of correction factors:

0,85 for double-core cables;

0,7 for triple- and quadruple-core cables.

16.8.2.4 The permissible current ratings for cables and wires in circuits of intermittent or shorttime service shall be determined by multiplying the current ratings for continuous service stated in Table 16.8.2.1 or chosen according to 16.8.2.2 by the correction factors given in Table 16.8.2.4.

16.8.2.5 The permissible current ratings given in Table 16.8.2.1 refer to the ambient temperature of +45 °C.

The correction factors for converting the permissible current ratings to be introduced depending on the ambient temperature are stated in Table 16.8.2.5.

16.8.2.6 In choosing the cables for final branch circuits of lighting and cooking appliances correction factors or simultaneity factors are not applicable.

16.8.2.7 The cables shall be so designed that they could withstand maximum short-circuit current occurred in the circuit considering time and current ratings of the protective devices and peak value of the prospective short-circuit current of the first onehalf period.

16.8.2.8 Cables installed in parallel and belonging to the same phase or pole shall be of the same type, be laid together and have the same cross-sectional area of at least 10 mm² and the same length.

Table 16.8.2.4

Correction factors for cables and wires with or without metal sheathing

Nominal cross-section of conductor, mm ²	Intermittent service, intermittence ratio, 40 %		Short-time service, 30 min		Short-time service, 60 min	
	Cable and wire					
	with metal sheathing	without metal sheathing	with metal sheathing	without metal sheathing	with metal sheathing	without metal sheathing
1	1,24	1,09	1,06	1,06	1,06	1,06
1,5	1,26	1,09	1,06	1,06	1,06	1,06
2,5	1,27	1,10	1,06	1,06	1,06	1,06
4	1,30	1,14	1,06	1,06	1,06	1,06
6	1,33	1,17	1,06	1,06	1,06	1,06
10	1,36	1,21	1,08	1,06	1,06	1,06
16	1,40	1,26	1,09	1,06	1,06	1,06
25	1,42	1,30	1,12	1,07	1,06	1,06
35	1,44	1,33	1,14	1,07	1,07	1,06
50	1,46	1,37	1,17	1,08	1,08	1,06
70	1,47	1,40	1,21	1,09	1,09	1,06
95	1,49	1,42	1,25	1,12	1,11	1,07
120	1,50	1,44	1,28	1,14	1,12	1,07
150	1,51	1,45	1,32	1,17	1,14	1,08
185	—	—	1,36	1,20	1,16	1,09
240	—	—	1,41	1,24	1,18	1,10
300	—	—	1,46	1,28	1,20	1,12

Table 16.8.2.5

Correction factors depending on ambient temperature

Maximum permissible conductor operating temperature, °C	Ambient temperature, °C										
	35	40	45	50	55	60	65	70	75	80	85
60	1,29	1,15	1,00	0,82	—	—	—	—	—	—	—
65	1,22	1,12	1,00	0,87	0,71	—	—	—	—	—	—
70	1,18	1,10	1,00	0,89	0,77	0,63	—	—	—	—	—
75	1,15	1,08	1,00	0,91	0,82	0,71	0,58	—	—	—	—
80	1,13	1,07	1,00	0,93	0,85	0,76	0,65	0,53	—	—	—
85	1,12	1,06	1,00	0,94	0,87	0,79	0,71	0,61	0,50	—	—
90	1,10	1,05	1,00	0,94	0,88	0,82	0,74	0,67	0,58	0,47	—
95	1,10	1,05	1,00	0,95	0,89	0,84	0,77	0,71	0,63	0,55	0,45

16.8.3 Selection of cable cross-sectional areas for permissible voltage drop.

16.8.3.1 Voltage drop on the cable connecting the generators of the main switchboard or the emergency switchboard shall not exceed 1 %.

16.8.3.2 Voltage drop between busbars of the main or emergency switchboard and any points of the installation shall not exceed 6 % of the rated voltage under normal operating conditions; for consumers supplied from the accumulator battery with the rated voltage up to 50 V this value may be increased to 10 %.

For circuits of navigation lights it may be required to limit the voltage drop by a lesser value in order to ensure necessary luminous intensity.

At short-term loads (e.g. when starting the electric motors) the greater voltage drop may be permitted if it does not cause disturbance of normal operation of the ship's electrical installation.

16.8.3.3 The cables used for feeding the directly-started alternating current electric motors shall be computed in such a manner that the voltage drop on motor terminals at starting is not over 25 % of the rated voltage.

16.8.4 Installation of cables.

16.8.4.1 Cables shall be installed in runs, which shall be, as far as possible, straight and accessible.

The cable runs shall pass through locations where cables are not exposed to oil, fuel, water and excessive external heating.

Cable runs shall be installed not closer than 100 mm to sources of heat.

16.8.4.2 No cables shall be installed at a distance less than 50 mm from the double bottom and from the fuel and oil tanks.

Cable runs shall be installed at a distance not less than 20 mm from the shell plating, as well as from fireproof watertight and gastight bulkheads and decks.

16.8.4.3 For bunches of cables consisting of cable types, which have not been subjected to a bunch fire test, the following measures shall be taken during installation to limit the propagation of fire:

.1 fire-retarding divisions shall be used, B-0 class at least, (refer also to 2.1.2.5, Part VI "Fire

Protection") where bunches enter the main and emergency switchboards, central control stations and consoles for the main propulsion plant and for important auxiliaries, as well as at each entry and exit point of cable runs in fully enclosed metal conduits (Fig. 16.8.4.3.1);

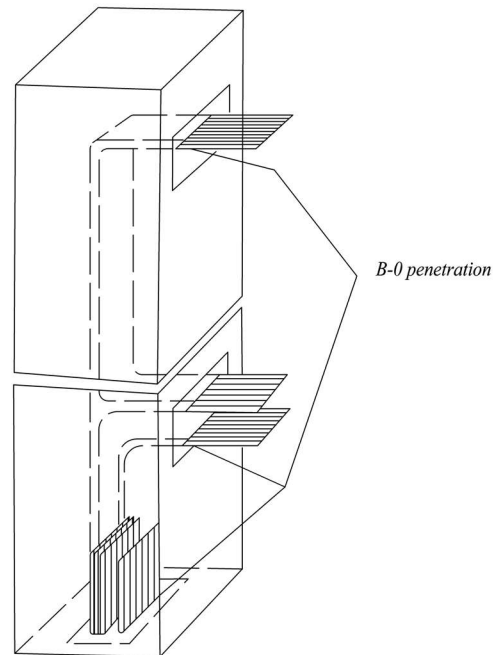

Fig. 16.8.4.3.1

Fully enclosed cable run protected with B-0 fire-retarding divisions

.2 in closed and semi-enclosed rooms and spaces, bunches installed in partly enclosed and open cable runs shall be protected by: flameproof coatings over the entire length of vertical cable runs and over a length of 1 m every 14 m apart on horizontal cable runs (Fig. 16.8.4.3.2-1); or

B-0 fire-retarding divisions at least at every second deck or every 6 m apart for vertical cable runs and every 14 m apart for horizontal cable runs (Fig. 16.8.4.3.2-2). Fire-retarding divisions shall be

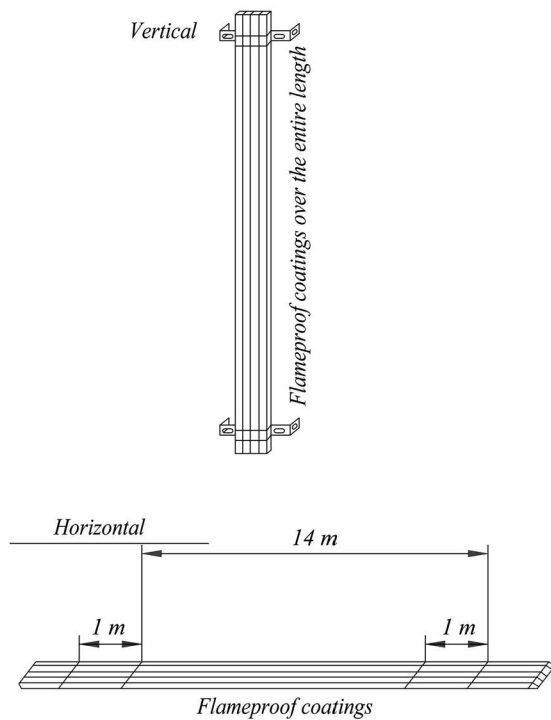

Fig. 16.8.4.3.2-1 Cable runs protected with flameproof coatings

made of steel plates at least 3 mm thick and having dimensions as shown in Fig. 16.8.4.3.2-2;

.3 bunches installed in cargo holds shall be protected by B-0 fire-retarding divisions at least at the entry and exit points of cable runs.

16.8.4.4 Cables having external metallic sheaths may be installed on structures of light metal or be fastened in position by means of cable clips of light metal only in cases where reliable anticorrosive protection is provided.

16.8.4.5 In the holds of dry cargo ships intended for the carriage of dangerous cargoes, no through runs of cables shall, generally, be installed.

Where such cable-laying is necessary the requirements of 2.9 shall be fulfilled.

16.8.4.6 Cables installed in fishing vessels at locations subjected to the action of salt shall be adequately protected with casings or be provided with salt-resistant sheaths.

16.8.4.7 No cables are recommended to be installed under the flooring of machinery spaces. If such installation is required, cables shall be laid in metallic pipes or in closed conduits (refer to 16.8.8).

16.8.4.8 Cables installed across expansion joints in the hull structure shall be provided with expansion loops having a radius adequate for such joint. The inside diameter of a loop shall not be less than 12 outside diameters of the cables.

16.8.4.9 Installation of cables having insulation intended to withstand different permissible temperatures in the common cable runs shall be effected in

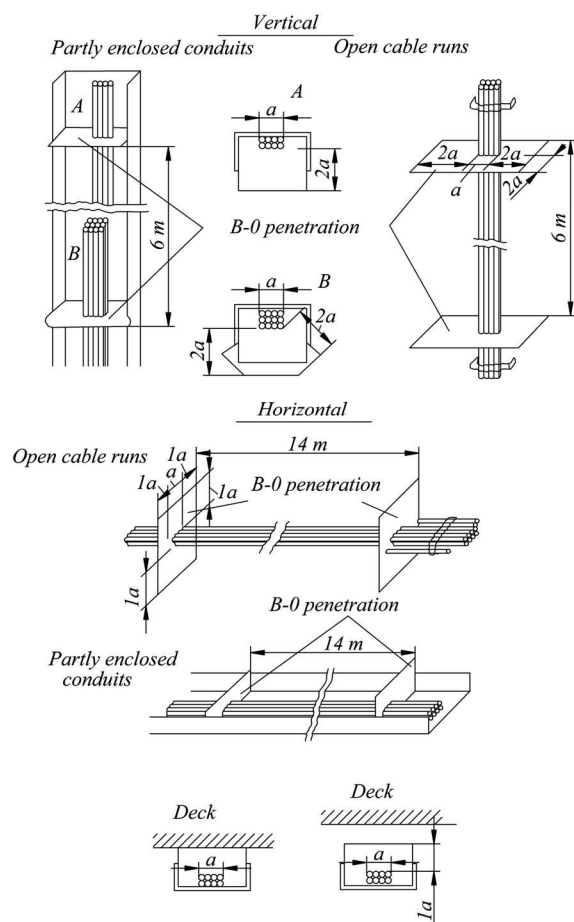

Fig. 16.8.4.3.2-2 Cable runs protected with B-0 fire-retarding divisions

such a manner that the cables are not heated above their permissible temperature.

16.8.4.10 Cables with different protective coverings the less hard of which may be damaged shall not be installed in one common pipe, one common duct or in other runs of not supported common laying.

16.8.4.11 Cores in multi-core cables shall not be used for supplying power and control currents to essential services not associated with one another.

Multi-core cables shall not be used simultaneously for safety voltage and service voltages exceeding the safety level.

16.8.4.12 When machinery is energized through two separate feeders, these feeders shall be installed in different runs as far apart as possible in horizontal and vertical directions.

16.8.4.13 When installing cables in ducts or other structures of combustible material, the ways of cable installation shall be protected from igniting by means of suitable fire protection, such as lining, coating or impregnation.

16.8.4.14 Cables shall not be embedded into thermal or acoustic insulation in case it is made of

combustible materials. Cables shall be separated from such insulation by the lining of non-combustible materials or shall be installed at a distance at least 20 mm from it.

When cables are laid in thermal or acoustic insulation made of combustible materials, they shall be computed with relevant reduction in current rating.

16.8.4.15 Cables installed in refrigerated spaces shall be provided with protective sheath of metal, polychloroprene composition, or of any other material resistant to the exposure of the cooling agent.

If cables are provided with armour, this armour shall be adequately protected against corrosion.

16.8.4.16 Cables in refrigerated spaces shall be installed on perforated panels or bridges and fastened in position in such a manner that a free space is reserved between the cables and the walls of the room. Panels, bridges and cable clips shall be protected against corrosion.

If cables cross the thermal insulation of a refrigerated space, these cables shall run at right angles through an appropriate gland pocket on both ends.

16.8.4.17 When installing the cables, minimum internal bending radii shall be maintained in accordance with Table 16.8.4.17.

16.8.4.18 Cables and earthing conductors of equipment mounted on shock absorbers shall be installed in such a manner that they cannot be damaged in service.

16.8.4.19 Cables laid on the open parts of the ship and masts shall be protected against direct exposure to sun radiation.

16.8.5 Fastening of cables.

16.8.5.1 Cables shall be adequately fastened in position by means of clips, holders, hangers, etc., manufactured of metal or other non-combustible material.

The fastener surface shall be sufficiently wide and to have no sharp edges. The fasteners shall be selected in such a manner that the cables are securely fastened in position without damage to their protective coverings.

16.8.5.2 Distances between cable fastening points in case of horizontal installation shall not exceed the values given in Table 16.8.5.2.

Table 16.8.5.2

External diameter of cable, mm		Distance between fastening points for cables, mm		
over	up to	without armour	with armour	with mineral insulation
—	8	200	250	300
8	13	250	300	370
13	20	300	350	450
20	30	350	400	450
30	—	400	450	450

When laying cable runs on cable ladders inside spaces the distance between cable fastening points may be enlarged up to 900 mm. Meanwhile, the distance between the supports of cable runs (ladder rung) shall not exceed 400 mm.

For vertical runs of cables these distances may be increased by 25 %.

16.8.5.3 Cables shall be fastened in such a manner that mechanical strains in cables, if any, are not transmitted to their inlets or connections.

16.8.5.4 Cable runs and cables installed parallel to shell plating shall be fastened to ship's structures.

On watertight bulkheads and masts, cables shall be fastened on special supports (saddles, tray plates, chocks, etc.).

16.8.5.5 Cables running parallel to bulkhead subject to sweating shall be installed on bridges or on perforated panels in such a manner that free space is reserved between cables and bulkheads.

Table 16.8.4.17

Type of cable		External diameter of cable, in mm	Minimum bending radius of cable
Insulation material of cable	Protective covering of cable		
Rubber or polyvinylchloride	Armoured with metal tape or wire	Any	10 <i>d</i>
	Protected with metal sheath	Any	6 <i>d</i>
	Lead alloy and armour	Any	6 <i>d</i>
	Other sheaths	Up to 9,5	3 <i>d</i>
		9,5 — 25,4	4 <i>d</i>
		Over 25,4	6 <i>d</i>
Varnished cambric	Any	Any	8 <i>d</i>
Mineral insulation	Metal	Up to 7	2 <i>d</i>
		7 — 12,7	3 <i>d</i>
		Over 12,7	4 <i>d</i>
Ethylene-propylene rubber or cross-linked polyethylene	Semiconducting and/or metal	25 and over	10 <i>d</i>

16.8.5.6 Cable runs shall be installed with a minimum number of crossings. Bridges shall be used at places where cables cross each other. An air gap of not less than 5 mm shall be left between the bridge and the cable run crossing it over.

16.8.5.7 For ships constructed from non-conducting materials it is permitted, due to the technology of hull construction from these materials, the properties of the materials used, etc., to accept the equivalents to the requirements for the installation, fastening and sealing of penetrations of cables and cable runs specified in the Rules for steel ships.

16.8.6 Cables penetrating decks and bulkheads.

16.8.6.1 Cable penetrations through watertight, gastight and fire-resisting bulkheads and decks shall be sealed.

Sealings where cables penetrate through the above bulkheads and decks shall not reduce their tightness; no force shall be transmitted to cables resulting from elastic deformations of ship's hull.

16.8.6.2 When installing the cable through non-tight bulkheads or elements of ship's structure less than 6 mm thick, linings or bushings that will prevent damage to cables shall be provided.

When bulkheads or ship's structure is 6 mm or more thick, no linings or bushings are required, but the edges of holes shall be rounded.

16.8.6.3 Installation of cables over watertight decks shall be effected by one of the following methods:

.1 in metal pipes (shafts) protruding above the deck to a height of not less than 900 mm in locations where mechanical damage to cable is possible and to a height not less than that of the door sill in spaces where there is no risk of such damage;

.2 in common metal sockets or boxes with additional protection of cables by enclosures having the height specified in **16.8.6.3.1**.

Cable boxes shall be packed with cable compound, while the pipes shall be provided with glands or be stuffed with cable compound.

16.8.7 Packing compounds.

16.8.7.1 To fill the cable boxes in watertight bulkheads and decks, the use shall be made of packing compounds having good adhesion to the inside surfaces of cable boxes and cable sheath that will withstand the action of water and oil products, will not shrink and lose its tightness in continuous service under conditions specified in 2.1.1 and 2.1.2.

16.8.7.2 Packings of cable penetrations through fire-resisting bulkheads shall withstand standard fire test specified for the given type of bulkhead in 2.1.2, Part VI "Fire Protection".

16.8.8 Installation of cables in pipes and conduits.

16.8.8.1 Metallic pipes and conduits wherein cables are installed shall be protected from corrosion on the inside and the outside surfaces. The inside surface of pipes and conduits shall be even and smooth. Ends of pipes and conduits shall be machined or protected in such a manner that no damage is caused to the cables when they are being pulled in.

Cables with lead sheaths not having any additional protective covering shall not be installed in pipes and conduits.

16.8.8.2 Pipe bending radius shall not be smaller than the permissible radius for cable of the largest diameter installed in this pipe (refer to **16.8.4.18**).

16.8.8.3 The total cross-sectional areas of all cables measured on their outside diameters shall not exceed 40 % of the inside cross-sectional area of the pipe and the conduit.

16.8.8.4 The pipes and conduits shall be mechanically and electrically continuous and securely earthed if the earthing has not been already effected by the method itself of pipe and conduit installation.

16.8.8.5 The pipes and conduits shall be installed in such a manner that no water can accumulate therein. When required, ventilation holes shall be provided in the pipes and conduits, as far as possible, in the highest and lowest points, so that circulation of air is ensured and vapour condensation is prevented. Holes in pipes and conduits are permissible only at places where it will not enhance the danger of explosion or fire.

16.8.8.6 Cable pipes and conduits installed alongside ship's hull, which can be damaged due to deformation of ship's hull, shall be provided with compensation devices.

16.8.8.7 If in accordance with **16.8.1.1**, the use is allowed of cables with combustible covering, these cables shall be installed in metallic pipes.

16.8.8.8 Cables installed in pipes and conduits vertically shall be fastened so that they are not damaged under tension due to gravity.

16.8.8.9 It is allowed to use cable trays/protective casings of the approved type made of reinforced and plain thermoplastic polymeric materials like polyvinylchloride (PVC) or fiber reinforced plastic (FPR).

The protective casing shall have round or other closed cross-section.

16.8.8.10 Cable trays/protective casings made of polymeric materials shall be supplemented by metallic fixing and straps such that in the event of a fire they, and the cables affixed, are prevented from

falling and causing an injury to personnel and/or an obstruction to any escape route.

When cable trays/protective casings made of polymeric materials are used on open deck, they shall additionally be protected against UV radiation.

16.8.8.11 The load on the cable trays/protective casings made of polymeric materials shall be within the safe working load (SWL). The support spacing shall not be greater than the manufacturer's recommendation nor in excess of spacing at the SWL test.

In general the spacing shall not exceed 2 m.

The selection and spacing of cable tray/protective casing supports shall take into account:

cable trays/protective casings' dimensions; mechanical and physical properties of their material; mass of cable trays/protective casings; loads due weight of cables, external forces, thrust forces and vibrations; maximum accelerations to which the system may be subjected; combination of loads.

16.8.8.12 The sum of the cables installed in cable trays/protective casings made of polymeric materials total cross-sectional area shall not exceed 40 % of the protective casing's internal cross-sectional area. This does not apply to a single cable in a protective casing.

16.8.9 Special precautions for single-core cables for a.c. wiring.

16.8.9.1 A.c. wiring shall not be carried out, as far as possible, in single-core cables. When, however, it is necessary to use single-core cables for circuits rated in excess of 20 A, the following precautions shall be observed:

.1 the cables shall be armoured with non-magnetic material;

.2 cables belonging to one circuit shall be placed in the same run or metal pipe and shall be as short as practicable. Each of such cables may be installed separately under a non-magnetic screen (in a pipe) earthed at one point and isolated from the screens of other cables and from the hull;

.3 cable clamps, unless they are made of non-magnetic material, shall include all the single-core cables of a circuit;

.4 the distance between the cables shall not be greater than one cable diameter.

16.8.9.2 Where single-core cables pass through bulkheads or decks, there shall be no magnetic material between cables belonging to the same circuit. The clearance between the cables and the magnetic material shall not be less than 50 mm.

16.8.9.3 When single-core cables having a current rating greater than 250 A are installed near steel structures, the clearance between the cables and the structure shall be at least 50 mm.

16.8.9.4 When single-core cables of a conductor cross-section of 185 mm² or over are installed, a transposition of phases shall be effected at intervals not exceeding 15 m. Where cable length is below 30 m, no transposition is necessary.

16.8.9.5 Multicore cables with conductors in parallel shall be installed as single-core cables, and all the requirements for single-core cables apply in this case.

16.8.10 Connection and tapping of cables.

16.8.10.1 Ends of rubber-insulated cables to be introduced into machines, apparatus, switchgear and other equipment shall be provided with contact, protection and packing terminals that will ensure reliable electrical contact, will not permit moisture to penetrate inside the cable and will protect the insulation of cable cores from mechanical damage and effects of air and oil vapours.

At places of connection, rubber-insulated cable cores shall be provided with protective insulation against damage (wear, etc.).

16.8.10.2 Protective covering of a cable inserted into a device shall enter not less than 10 mm inside.

16.8.10.3 At places of tappings, connection of cables shall be effected in junction boxes by means of clamps.

16.8.10.4 If during the installation of cables it is necessary to make additional connections, these shall be effected in suitable junction boxes provided with clamps. The joint as a whole shall be protected from ambient conditions. Other methods of cable connection approved by the Register may be allowed.

17 ELECTRIC PROPULSION PLANTS

17.1 GENERAL

17.1.1 The requirements of this Section apply to all electric propulsion plants and their equipment, as well as to manufacture, installation and tests including:

- .1 generators and their prime movers;
- .2 switchboards;
- .3 transformers/reactors;
- .4 semiconductor frequency converters;
- .5 electric propulsion motors;
- .6 excitation arrangements (units);
- .7 arrangements (units) of control systems of electric propulsion plants, monitoring systems (alarm system, indication and logging systems), as well as safety devices;
- .8 power bus ducts and cable runs of production systems and power distribution in electric propulsion plants.

17.1.2 The requirements of the present Section do not apply to bow and aft thrusters being auxiliary arrangements for ship's steering.

17.1.3 The requirements of the present Section and applicable requirements of other Sections of the present Part are mandatory for ships with the character of classification supplemented with the mark EPP in compliance with the requirements of 2.2.12, Part I "Classification".

17.1.4 The electrical equipment of the electric propulsion plant shall meet the requirements of other sections and chapters of the present Part unless otherwise specified in the present Section.

17.1.5 In electric circuits of electric propulsion plants the voltage used shall not exceed those specified in 4.2 and Section 18.

17.1.6 It is recommended to provide electric heating in spaces enclosing electrical machines, switchboards and control panels.

17.1.7 Stationary lighting shall be provided underneath generators and motors of the electric propulsion plant.

17.1.8 Parts of electric propulsion machines (motors and generators) located under the floor shall have the degree of protection not below IP56.

Where they are installed in a dry compartment or protected against the ingress of water by a watertight foundation, and additionally, an alarm operating with the ingress of water in that compartment is provided, degree of protection IP23 may be allowed.

17.1.9 Provisions shall be made for arrangements preventing the generation and accumulation of moist-

ure and condensate, in particular, while being idle for a long time, in casings of electric propulsion motors, generators, semiconductor frequency converters and other electric propulsion plant components. These arrangements may be electric heaters, air dryers, etc.

17.1.10 Electric propulsion plant shall be fitted with an arrangement for insulation resistance monitoring complying with the requirements of 2.11.

17.2 DEFINITIONS AND EXPLANATIONS

17.2.1 For the purpose of the present Section the following definitions and explanations have been adopted.

Azimuth drive — drive which moves the propulsion unit around the vertical axis.

Main control station of the electric propulsion plant — control station of the main propulsion plant which is attended under seagoing condition.

Electric propulsion plant — set of equipment for distribution and conversion of electrical power into mechanical one in order to reproduce a predetermined torque by one propeller propulsion.

Double sensor — a sensor with two sensor elements in one housing.

Unified Electric power plant — electric power plant united with the propulsion plant which ensures ship propulsion.

Local control station — control station located where a system intended for selection and input of reference values for semiconductor frequency converters or electric propulsion system external devices (units) control intended for semiconductor frequency converters which is independent from reference values for remote control system and any external are installed.

Podded drive — propulsion plant in which the electric propulsion motor is located in a dedicated, submerged unit (pod housing) of the ship.

Redundant sensor — two single sensors in separate housings to control the same parameter.

Electric propulsion system — coherent set of interrelated functional units implemented in electric power plant, interacting with a source of electric power to control the focus with the specified dynamic performance and set algorithms.

Electric power plant — complex of marine electrical equipment united by the process of production, distribution and conversion of electrical

power into other forms of power (mechanical, thermal, light, chemical, etc.

17.3 CONFIGURATION OF ELECTRIC PROPULSION PLANTS

17.3.1 The electric propulsion plant includes the following devices:

.1 main generators of electric propulsion plant with its control devices — at least 2;

.2 main switchboard separated in two parts with a section circuit breaker or break switch;

.3 power transformers for a galvanic isolation or conversion of the main switchboard voltage to that of semiconductor frequency converters — one per each converter;

.4 power semiconductor frequency converters to supply the electric propulsion motor,— at least 2;

.5 arrangements (units) of control or controller of electric propulsion plants;

.6 electric propulsion motor stator with two systems of stator windings supplied from the relevant semiconductor frequency converter.

17.3.2 For electrical propulsion plants with one electric propulsion motor, synchronous, asynchronous and electronically commutated main propulsion motors shall have two systems of stator windings supplied from the relevant semiconductor frequency converter. Each converter shall be designed for at least 50 % of the rated power of the electric propulsion plant. If the ship is equipped with several electric propulsion motors at the common shaft with the propeller of the main electric propulsion plant or with several main propulsion plants, the use of electric propulsion motors with one system of stator windings is permitted.

17.3.3 Propulsion DC motors shall be of the double-armature (double-commutator) type with each armature winding designed for at least 50 % of the rated power of the plant. Each armature winding shall be supplied from its independent converter. Any single failure in one converter shall not result in complete loss of power.

17.3.4 Provision shall be made for braking or locking devices as part of the shafting to prevent its free rotation with a switched-off propulsion motor (shaft) at any environmental conditions or during ship towing.

17.3.5 Electric Propulsion System structure and control algorithm provided by some electric propulsion plants shall follow the one failure principle, i.e. if any component of the electric propulsion plant fails, a ship shall be underway at least at the partial power.

17.3.6 Provision shall be made for a warning alarm at all active control stations when any failure occurs in the electric propulsion plant.

17.3.7 For all auxiliary machinery and essential services, provision shall be made for local control stations to which control is transferred if the remote automated control system of the electric propulsion plant fails.

17.4 EXCITATION SYSTEMS

17.4.1 General.

17.4.1.1 Every excitation system shall be supplied by a separate feeder. The obtainable current and voltage of the excitation system, as well as source of power shall fully comply with the requirements for all electric propulsion plant modes including manoeuvring, overcurrent and short circuit, as well as the capsizing moment conditions.

17.4.1.2 Power supply of excitation systems shall be protected against short circuits only. The activation of an electromagnetic release at short circuit shall be supplemented with an alarm at control stations.

17.4.1.3 If the built-in short-circuit monitoring device of the excitation system trips, the respective circuit breaker of the generator or propulsion motor shall also trip.

17.4.1.4 If the excitation system is fitted with independent safety devices against underfrequency and over-voltage or U/f-functions, they shall be adjusted in such a way that the system protection reacts first.

17.4.1.5 Excitation circuits shall be provided with means for suppressing voltage rise when an excitation switch is opened (field suppression system).

17.4.1.6 Means (filters, etc.) shall be provided to limit harmonic distortions and reduce a power factor.

17.4.2 Generator excitation.

17.4.2.1 Excitation systems shall be supplied from the generator, the generator shall be self-excited.

The voltage built up shall be done without the aid of external sources of electrical power.

17.4.2.2 External source of electrical power may be used for exciter control circuits, as well as for initial excitation, provided it is redundant.

The external source of power shall be supplied from the main and emergency switchboards and, additionally, from the standby accumulator battery. At least two external sources of power for all electric propulsion plant generators shall be provided.

17.4.3 Electric propulsion motor excitation.

17.4.3.1 The exciter shall be supplied directly from the same main switchboard section supplying the stator winding.

17.4.3.2 Excitation systems and automatic control systems shall protect electric propulsion motors from overspeeding in the event of the propeller breaking down or working clear of water.

17.5 ELECTROMAGNETIC COMPATIBILITY (EMC)

17.5.1 The electric propulsion plant shall operate without malfunctions and failures being exposed to electromagnetic interference, and comply with the requirements of 2.2.

17.5.2 Equipment producing transient voltage, frequency and current variations shall not cause malfunctions and failures of other equipment on board, neither by conduction, induction or radiation.

17.5.3 If a total harmonic distortion value of 10 % is exceeded when operating the propulsion plant, the appropriate filtering and interference-free operation of any consumers shall be ensured.

17.6 PRIME MOVERS OF ELECTRIC PROPULSION PLANT GENERATORS**17.6.1 Permissible speed deviations.**

17.6.1.1 If electric propulsion plant generators are also used for supplying the ship network, frequency deviations with the relevant load variations shall meet the requirements specified in 2.11.3, Part IX "Machinery".

17.6.1.2 Where the speed control of the propeller requires speed variation of prime movers of the electric propulsion plant generators, the governors shall be provided with means for local control as well as for remote control.

17.6.1.3 The prime movers rated power and overload capacity of the Unified Electric power plant generators shall be adequate to supply the power needed in the range of the operating conditions of the electrical equipment, as well as the electric propulsion plant load variations due to manoeuvring, at sea, including severe weather conditions.

17.6.2 Parallel operation.

17.6.2.1 In case of parallel operation of generators, the control system used shall ensure stable proportional distribution of loads over the entire output range of the prime movers as specified in 3.2.2.

17.6.2.2 In case the Unified Electric power plant generators (shaft generators) are used simultaneously for power supply and the electric propulsion plants containing reversible semiconductor frequency converters adapted to recover the power at braking of the electric propulsion motor and to retard the speed of the electric propulsion motor in reverse, the power plant control system shall ensure transmitting data on consumed active power from generators to define switching threshold of braking resistors shall be provided.

17.6.3 Reverse power.

17.6.3.1 When the propulsion motor is braking or reversing in emergency from full ahead running to full speed astern, the prime movers of an independent electric propulsion plant shall be capable of absorbing a proportion of the recuperated energy without tripping due to overspeed or reverse power.

17.6.3.2 To absorb a proportion of the recuperated energy and to retard the speed of the electric propulsion motor of an independent electric propulsion plant, braking resistors may be used ensuring the necessary limits on the prime movers and the electric propulsion plant generators speed. The amount of recuperated work shall be limited by DMS controllers.

17.7 ELECTRIC PROPULSION PLANT GENERATORS**17.7.1 General.**

17.7.1.1 Generators (shaft generators) operating with semiconductor converters shall be designed for the expected harmonics of the system. While designing the Electric power plant and selecting the generators' rated power, a sufficient output reserve shall be provided to prevent the generator temperature rise, compared with the sinusoidal load.

17.7.1.2 Stator windings of generators with rated power output above 500 kVA shall be provided with temperature sensors.

17.7.1.3 Electric propulsion plant generators shall be fitted with cooling air cleaning filters open-circuit and closed-circuit ventilation. For alternating current brushless generators with closed-circuit ventilation the cooling air cleaning filters are not mandatory. Ventilation ducts shall be arranged so as to prevent water ingress into the machine.

17.7.1.4 Electric propulsion plant generators may be used for supplying auxiliary electrical machinery and services provided voltage and frequency are stable under all conditions, including manoeuvring, in compliance with the requirements of 2.1.3.

17.7.1.5 No circuit breakers shall be fitted in excitation circuits of generators except those which remove excitation of machinery at short circuits or damages in the main current circuit.

17.7.1.6 Means of protection of generators shall comply with the requirements specified in 8.2. For generators with the ratings more than 1500 kVA, protection against internal faults shall be provided.

17.7.2 Generator bearings and lubrication.

17.7.2.1 Sliding bearing shells shall be easily replaceable. Provision shall be made for checking the bearing lubrication. Adequate lubrication shall be provided even at the maximum potential trim.

Provision shall be made for relevant seals to prevent oil ingress inside the generator.

17.7.2.2 In case of bearings with forced lubrication (under pressure), the following alarms, as a minimum, shall be provided at the Electric propulsion plant control stations:

.1 failure of lubricating system (no flow of lubricating oil, failure of lubrication pump, loss of pressure in the lubrication pipe, etc.);

.2 maximum temperature of each bearing.

17.7.2.3 Generators shall be fitted with backup (emergency) devices for bearings lubrication which, in the event of malfunction or failure of the main (working) lubricating system, provide adequate lubrication until the machine full stop.

17.7.2.4 To avoid damage to bearings, provision shall be made to ensure that no currents can flow between the bearing and the shaft.

17.7.3 Generators cooling.

17.7.3.1 In addition to thermometers, temperature sensors of cooling air shall be provided which shall initiate an alarm with the excess of a permissible temperature.

17.7.3.2 For machines with a closed circuit cooling and heat exchanger, the flow of primary and secondary coolants shall be monitored. An alarm shall be initiated with the flow failure.

17.7.3.3 Leakage-water and condensed moisture shall be kept away from the machine windings. Provision shall be made for an alarm to monitor leakage.

17.8 ELECTRIC PROPULSION PLANT SWITCHBOARDS

17.8.1 Electric propulsion plant switchboards shall meet the requirements of 4.6 and 18.6.

17.8.2 Electric propulsion plant system shall be fitted with an arrangement for insulation resistance monitoring (refer to 2.11).

17.8.3 Switches for routine switching in de-energized circuits of the electric propulsion plant shall be provided with an interlocking device to prevent their tripping under voltage, or false switching.

17.9 ELECTRIC PROPULSION PLANT POWER TRANSFORMERS

17.9.1 General.

17.9.1.1 Transformers and reactors shall meet the requirements of Section 11 and 18.4.

17.9.1.2 Provision shall be made for at least two independent power transformers for the electric propulsion plant. Only transformers with separate windings shall be used.

17.9.1.3 The winding temperatures of transformers used in electric propulsion plants shall be monitored with a sensor and indicator system.

17.9.1.4 For current measurements on the primary side in each phase supplying the Electric propulsion plant transformer, ammeters shall be provided on the main switchboard.

17.9.1.5 Each Electric propulsion plant transformer shall have overcurrent and short circuit protection on the primary and secondary side.

For protection on the secondary side, Electric propulsion plant semiconductor converter may be used.

17.9.2 Liquid cooled electric propulsion plant transformers.

17.9.2.1 Windings of liquid cooled transformers shall be completely covered by liquid, even for inclinations up to and including 22,5°.

17.9.2.2 Transformers shall be provided with the necessary collecting and accumulating arrangements for coolant leaks.

Fire detectors and fire-fighting equipment shall be installed in the vicinity of the transformer. The fire-fighting equipment may be manually operated.

17.9.2.3 Transformers shall be fitted with protection against gassing of coolant.

17.9.2.4 The coolant temperature shall be monitored with a sensor system. A pre-alarm shall be actuated before the maximum permissible temperature is attained. When the maximum permissible temperature limit is reached, a separate sensor shall activate protection which switches off the transformer.

17.9.2.5 The coolant level shall be monitored by two sensors, one of them shall actuate an alarm and the other set up to the maximum permissible level shall switch off the transformer.

17.9.3 Air cooled electric propulsion plant transformers.

17.9.3.1 The operation of fans for transformers cooling, as well as the cooling air temperature shall be monitored with a sensor system.

An alarm shall be given at the excess of temperature or fan failure.

17.9.3.2 Where a closed circuit cooling air system with an air cooler is used, in addition to the requirements of 17.9.3.1, the following shall be monitored:

.1 the minimum flow of primary and secondary coolants (air and water);

.2 heat exchanger leakage to be alarmed.

The heat exchanger shall be so installed that water leakages and condensed moisture are kept away from the windings.

17.10 ELECTRIC PROPULSION PLANT SEMICONDUCTOR CONVERTERS

17.10.1 General.

17.10.1.1 Converters shall meet the requirements of Section 12.

17.10.1.2 At least two entirely independent separate semiconductor converters shall be provided to feed separate winding systems of Electric propulsion plant (or separate Electric propulsion plants).

17.10.1.3 Each converter shall be provided with a separate unit or a control system.

17.10.1.4 There shall be provided two galvanically isolated speed sensors for each unit or device of control system. Common housing of both sensors is permitted.

17.10.1.5 If the converter feeds a permanently excited electric propulsion motor of direct or alternative current (including those of permanent magnet), a switch disconnecter shall be fitted in the "motor - converter" line which opens automatically in case of an inverter or rectifier fault. Devices shall be provided for such faults diagnosis.

17.10.1.6 Electric propulsion plant converters shall be designed for the nominal torque of the drive (nominal torque at a propeller shaft). Short - term overloads and speed variations (dips) resulting from overloads or the load throwing off at propeller emergence shall not lead to the activation of converter protection.

17.10.1.7 The recuperated energy may be received to the Unified Electric power plant at retarding the speed of the electric propulsion motor in reverse via the reversible semiconductor frequency converters to ensure the quality parameters (refer to 2.1.3) for the ship's power consumers. The excess of the recuperated energy shall be absorbed by "braking resistors".

17.10.1.8 Reactive power may be compensated by means of reversible semiconductor frequency converters. Thus, the control unit shall receive a signal from control system of the Electrical power plant to comply with the current value of the reactive power being generated by the power consumers of the Unified Electric power plant.

17.10.1.9 The cabinets for semiconductor converters shall meet the requirements of 4.6 and Section 18.

17.10.1.10 The design of the cabinets for semiconductor converters shall provide for the quick exchange of power components of the built-in equipment. This may be achieved by use of modular design for power circuit, its components, control, protection and data display units.

17.10.2 Cooling of semiconductor converters.

17.10.2.1 If converters are fitted with a forced-cooling system, means for its monitoring shall be

provided. In case of a failure of the cooling system, measures shall be taken to prevent the overheat and failure of the converter.

17.10.2.2 The cooling system shall be provided with an alarm system. The alarm signal shall be generated by the reducing of a coolant flow or by high temperature of semiconductors.

17.10.2.3 Single failures in the converter cooling system shall not result in tripping all converters of the ship's electric propulsion plant.

17.10.3 Protection of semiconductor converters.

17.10.3.1 Operational overvoltages in a supply system of converters shall be limited by suitable devices to prevent breakdown of the components of the semiconductor frequency converters power circuit.

17.10.3.2 A suitable control system shall ensure that the rated current of semiconductor elements cannot be exceeded under all normal and most severe conditions.

17.10.3.3 Power circuit and the converter components shall be protected against damage and failure due to direct short-circuit at the terminals. Protection by fuses against short - circuit currents is permitted. The relevant feedbacks of the converter shall control (limit) the current in such way, that no components are damaged when the converter is switched on to a blocked motor.

17.11 PROTECTION ARRANGEMENTS FOR HARMONIC FILTERS

17.11.1 A harmonic filter shall be arranged as a three phase unit with individual protection of each phase on the main switchboard busbars at any step of propulsion.

17.11.2 Each individual filter circuits shall be protected against overcurrents and short-circuit currents. The fuses in filter circuits shall be monitored. Any fuse burnout shall be alarmed.

17.11.3 When designing and using line filters, their layout shall be designed for any conceivable line constellations. In particular, self-resonance shall be excluded under any load conditions and operating generators constellations.

17.11.4 In case of several parallel filter circuits, the current symmetry shall be monitored. An unsymmetrical current distribution in the individual filter circuits and the failure of the filter shall be alarmed.

17.11.5 Consideration shall be given to additional protection for the individual capacitor element (e.g. relief valve or overpressure disconnecter) in order to protect against damage from rupturing. This consideration shall take into account the type of capacitors used.

17.12 ELECTRIC PROPULSION MOTORS**17.12.1 General.**

17.12.1.1 Stator windings of a.c. motors and interpole, mainpole and compensation windings of d.c. motors of electric machines with a capacity above 500 kW, shall be provided with temperature sensors.

17.12.1.2 Regarding the design and lubrication of electric propulsion motor bearings, the requirements of 17.7.2 shall be met.

17.12.2 Electric propulsion motors cooling.

17.12.2.1 The cooling system shall ensure sufficient cooling under all load and speed conditions.

17.12.2.2 Electric propulsion motors shall be fitted with built-in temperature sensors which shall give an alarm signal with the excess of a permissible temperature.

17.12.2.3 For machines with a closed circuit cooling system and a heat exchanger, the flow of primary and secondary coolants shall be monitored.

17.12.2.4 Provision shall be made to alarm leakage. The heat exchanger shall be installed so that water leakages and condensed moisture are kept away from the windings.

17.12.2.5 If the cooling system of the propulsion motor fails, the emergency operation mode to ensure ship's manoeuvring under heavy navigating conditions shall be provided. Interventions by an operator for opening of emergency air flaps are permitted.

17.12.2.6 Air-cooled electric propulsion motors shall be fitted with air intake filters and two forced-air fans, each having a capacity sufficient for normal operation of the electric motor. A visual signal indicating fans operation and an alarm on their shutdown shall be provided.

17.12.2.7 A liquid cooling system for multi-armature machines shall be independent for each armature.

17.12.3 Protection of electric propulsion motor.

17.12.3.1 Over-current protection in the main and excitation circuits shall be set sufficiently high so that there is no possibility of its operating due to the over-currents caused by ship's maneuvering, operation in heavy seas or in broken ice.

17.12.3.2 Short-circuit and over-current protection may be provided by the converter. Different electric propulsion motor designs (d.c., synchronous, induction and permanent-magnet excitation motors) shall be taken into consideration.

17.12.3.3 For electric propulsion d.c. motors provision shall be made for an independent overspeed (runaway) protection device as required in 2.11, Part IX "Machinery".

The electric propulsion motor shall be capable to withstand overspeed up to the limit reached in

accordance with the characteristics of the overspeed protection device at its specified operational setting.

17.12.3.4 The motor shall be capable to withstand a sudden short-circuit currents at its terminals under nominal load without damage.

Steady state short-circuit current of a permanent excited motor shall not cause thermal damages of the motor and the current carrying components (e. g. slip rings, cables, feeders or busducts).

17.13 SPECIAL REQUIREMENTS FOR PODDED AZIMUTH THRUSTER DRIVES AND STEERABLE PROPELLER DRIVES**17.13.1 General.**

17.13.1.1 If the space, where an electrical machine and other equipment are located, is inaccessible during operation and associated with special environmental conditions (high temperature, humidity, etc.), special measures shall be taken like use of highly reliable materials and components, adequate number of sensors, as well as special means for protection of components against flooding and damages.

17.13.1.2 The components, e.g. controls, sensors, slip rings, cable connections and auxiliary drives shall withstand undamaged the strength of vibration, of at least 4g from 3 to 100 Hz.

17.13.2 Sensors.

17.13.2.1 Sensors which can be changed only during dry docking shall be fitted with two sensor elements in the same housing with separate data transmission channels.

17.13.3 Bearings.

17.13.3.1 Oil filling levels in bearing housings shall be monitored during operation and standstill. Any oil leakage shall activate an alarm.

This applies to circulated lubrication systems as well. These systems shall additionally be equipped with lubricating oil flow monitoring. A flow level monitoring alarm shall be independent from the electric propulsion motor control system.

17.13.3.2 The temperature of shaft bearings shall be monitored by an alarm and protection system. The alarm shall be carried out in two steps: alarm and engine stop. The protection system shall be independent from the temperature indication system for shaft bearings, and the alarm system.

17.13.4 Bilges in a pod housing.

The water level in pod bilges and associated spaces shall be monitored with level sensors. In addition to high level sensors in bilges operating for an alarm system, independent sensors to monitor a high emergency level shall be provided which prevent false operations and automatically stop the propulsion.

17.13.5 Fire detection system.

An effective fire detection system with the adequate number of sensors of the relevant type shall be provided. The general requirements for such systems are specified in 7.5.

17.13.6 Accessible spaces (in a pod housing).

Sufficient illumination and ventilation shall be provided for accessible spaces of the pod housing where regular maintenance work and equipment inspection are carried out.

17.13.7 Protection of the propulsion motor.

17.13.7.1 Motors of more than 1 MW and all permanent excited motors shall be provided with protection against internal faults that also monitors the connections between the semiconductor converter and the motor. The power supply to the defective equipment shall be interrupted with an appropriate time delay and an alarm shall be given.

17.13.7.2 Humidity shall be monitored for motors with closed air cooling systems. The excess of the permissible humidity level shall be alarmed.

17.13.8 Motor supply lines.

17.13.8.1 Cables operated at high temperature limits shall be installed separate from other cables. If required, splitters shall be provided to prevent contacts between cable sheaths.

17.13.8.2 IP protection for all terminals, cable glands and busbar connections shall be equal to motor protection, however, at least IP44. These requirements also apply to control cables.

17.13.9 Slip rings.

17.13.9.1 Where data from feedback sensors, controlled variable sensors, etc. are transmitted via a data bus of slip rings, the busbar shall be duplicated. Failure of each single busbar shall be alarmed.

17.13.9.2 Slip rings unit fitted with external forced cooling system shall be capable of operation without a cooling system for a certain period of time. The cooling system failure shall be alarmed.

17.13.10 Azimuth podded drive and Azimuth steerable propeller drive.

17.13.10.1 Azimuth drive shall meet the requirements for steering gear in accordance with the requirements of 5.5.

17.13.10.2 The single failure localization principle shall be ensured for all electrical and hydraulic components. Safe operation of the ship shall be ensured independently of the rudder angle and ship's speed at any time a failure occurs. The designer shall develop and submit for approval the "Failure Mode Effect Analyses" (FMEA).

17.13.10.3 The position of the azimuth drive shall be mechanically indicated on a scale at the drive location (steering compartment).

17.13.10.4 At least two independent electric drives shall be provided for each azimuthal unit for turn, whereby one drive shall be supplied from the main switchboard and the other, from the emergency switchboard.

17.13.10.5 Azimuth electric drives shall be protected against overcurrent (by converter, if applicable) and short circuit. They shall be able to supply 160 % of the torque necessary for the rated speed of movement in accordance with the requirements of 7.2.3, Part VII "Machinery Installations".

Azimuth drives with different design, e. g. hydraulic, shall also be able to fulfill the above requirements.

17.13.10.6 The thrust azimuth angle shall be limited to $\pm 35^\circ$. At low propulsion power rating and thus low ship's speed or crash-stop maneuver these limits may be disabled with the control system.

17.13.10.7 The thrust azimuth angle shall be limited related to the steps of the set ship's speed that the safety of the ship is not endangered (due to excessive thrust while turning). The limitation (interlock) shall be provided redundantly and independently of the control of the azimuth angle (pod turning).

17.13.10.8 Reaching or exceeding the permissible limitations of the azimuth angle shall be alarmed. After triggering the limitation, it shall be possible to move the azimuth drive back to the permitted angles of the drive turn without manual reset.

17.13.10.9 The operation and indication equipment of the azimuth drive shall be arranged in such a way that the set direction of the propeller thrust or the direction of the ship's moving is clearly indicated. It shall be clear to the operator whether the direction of the ship's moving or the direction of the propeller thrust of the electric propulsion plant was chosen.

17.13.10.10 The local control station for azimuthal unit shall be equipped with the following:

- .1 ammeters for each supply system of each load component;
- .2 azimuth angle (turn angle) indicators for each drive;
- .3 power supply system readiness for operation indicators for each drive;
- .4 power supply system disturbance indicators for each drive;
- and provide for the following:
 - .5 power limitation (from converter);
 - .6 control from main machinery control room;
 - .7 control from the navigation bridge;
 - .8 control from local control station;
 - .9 running indication for the associated propulsion drive.

The local control station can be activated locally at any time and shall have the highest priority.

17.14 ELECTRIC PROPULSION PLANTS CONTROL SYSTEMS

17.14.1 Powerplant control systems.

17.14.1.1 For power supply systems of electric propulsion plants with generators operating in parallel, the automated powerplant control system shall be provided which will ensure adequate power generation being consistent with the needs of specific operational modes of the electric propulsion plant, in transit/maneuver including. Automatic load based disconnection of generators in maneuver mode is not permitted.

17.14.1.2 In case of under-frequency on main switchboard busbars, overcurrent or overload and reverse power, the propulsion power shall be automatically limited (to prevent de-energizing of main switchboard busbars).

17.14.1.3 If generators are running in parallel and one of them is tripping by protection system, the automated power plant control system shall automatically reduce the electric propulsion plant load to protect the remaining generators against unacceptable overloads and ensure their operation at permissible loads. The same requirement applies to the main switchboard busbars tiebreakers.

17.14.1.4 Tripping of the main switchboard busbars tiebreaker shall not lead to any malfunction of the system. It is not necessary that the power plant control system remains in the automatic mode if the power supply system is split.

Any loss of the control system automatic functions shall be alarmed.

17.14.1.5 Electric power plant control system shall ensure transfer of information to Electric propulsion system as regards the current value of active capacity consumption from generators to restrict the power recuperated to the Unified Electric power system and determination of on threshold of "braking resistors".

17.14.1.6 Electric power plant control system shall ensure transfer of information to Electric propulsion system as regards the current value of reactive capacity consumption being generated by the power consumers of the Unified Electric power plant.

17.14.2 Location of the Electric propulsion plant control stations.

17.14.2.1 Electric propulsion plant control stations may be located at any convenient place according to the ship's purpose.

Where control stations are arranged outside the machinery space, i.e. on the bridge or in other locations, control stations in the machinery space or main machinery control room shall be provided as well.

17.14.2.2 The local control station has a priority and shall be located in the vicinity of the drive or

semiconductor converters. Changes of electric propulsion plant modes generated at this station shall be displayed by the system indicating a preset and executed commands.

17.14.2.3 Where several control stations are available, a control stations switch in the control station having a priority shall be provided. Such switch shall provide switching of any, but only one control station (central and wing stations on the navigation bridge are considered as one control station).

17.14.2.4 Each control station shall have an emergency stop device independent of the control system and the active (in "on" condition) control station.

17.14.3 Main and local control stations.

17.14.3.1 At least two mutually independent main and local control stations shall be provided for electric propulsion plant.

17.14.3.2 In case of damage, malfunctioning or loss of power supply of the main station control system, a local control station of the electric propulsion plant converters shall be provided.

17.14.3.3 The bridge shall be fitted with control systems such that the steering (azimuth thrust change) control system can operate independently of the speed and electric propulsion plant electric propulsion motor reverse control system.

17.14.3.4 All electric propulsion plant alarms shall be acknowledged at the local control station. Alarms which do not require any further intervention of the personnel can be acknowledged at the main control station (on the navigation bridge) with the mandatory follow-up acknowledgement at the local control station.

17.14.3.5 Restart of the electric propulsion plant shall be possible from both (main and local) control stations, depending on which one has been preselected. After the main switchboard de-energizing it shall be possible to restart the electric propulsion plant at the main control station.

17.14.3.6 If the electric propulsion plant is controlled from a panel or desk with the use of electric, pneumatic or hydraulic drive, the failure of them shall not result in electric propulsion plant tripping, and each control station at the panel or desk shall be immediately ready for manual operation.

17.14.3.7 Mechanically linked control stations installed in the wheelhouse (on the navigation bridge) for their synchronous operation may be permitted.

17.14.3.8 The remote control system of the electric propulsion plant shall be so designed that no time delay is needed for the personnel to move a control handle at a control station to a new position.

17.14.3.9 The electric propulsion plant control system shall be provided with an interlock to prevent the electric propulsion plant activation with a shaft turning gear engaged.

17.14.3.10 Each control station shall have a visual indication on the control system being alive.

17.14.4 Measuring, indicating and monitoring equipment.

17.14.4.1 Failures in measuring, monitoring and indicating equipment shall not result in failure of the electric propulsion plant control system, e. g., failure of the actual value (speed) sensor or of the reference speed value sensor shall not cause an excessive increase of propeller speed.

17.14.4.2 The local (active) control station shall be equipped with the following:

.1 ammeter for each power supply line of each load component (stator current of each winding, etc.), and also in the excitation circuit (for adjustable-excitation systems);

.2 voltmeters for each power supply line of each load component, and also for power supply of the excitation system (for adjustable-excitation systems);

.3 speed indicator for each shaft;

.4 "Powerplant ready for electric propulsion plant operation" indicator;

.5 "Powerplant disturbed" indicator;

.6 "Electric propulsion plant power limited" (from converter) indicator;

.7 "Control from the main machinery control room" indicator;

.8 "Control from the navigation bridge" indicator;

.9 "Control from the local control station" indicator.

17.14.4.3 The main control station (on navigation bridge) shall be equipped with the following:

.1 revolution indicator for each shaft;

.2 each shaft power meter;

.3 "Powerplant ready for switching on" (additional generators) indicator;

.4 "Power plant ready for electric propulsion plant operation" indicator;

.5 "Power plant disturbed" indicator;

.6 "Electric propulsion plant power limited" indicator;

.7 "Request to reduce power" indicator — if not automatically controlled or "override" button pushed (cancellation of the plant automated control);

.8 "Control from the main machinery control room" indicator;

.9 "Control from the navigation bridge" indicator;

.10 "Control from the local control station" indicator;

.11 indication of the generators operating at the electric propulsion plant;

.12 indication of power reserve (recommended).

17.14.4.4 When two or more control stations are provided for change of speed and angle of turn of CPP blades, both speed change and angle of turn of

CPP blades indicators shall be provided at each control station.

17.14.4.5 The main machinery control room shall be equipped with the following:

.1 speed indicator for each shaft;

.2 each shaft power meter;

.3 "Powerplant ready for switching on" (additional generators) indicator;

.4 "Power plant ready for electric propulsion plant operation" indicator;

.5 "Power plant disturbed" indicator;

.6 "Electric propulsion plant power limited" indicator;

.7 "Request to reduce power" indicator — if not automatically controlled or "override" button pushed (cancellation of the plant automated control);

.8 "Control from the main machinery control room" indicator;

.9 "Control from the local control station" indicator;

.10 "Control from the navigation bridge" indicator;

.11 indication of the generators operating at the electric propulsion plant.

The list of parameters controlled by the alarm system is given in Tables 17.14.4.5-1 and 17.14.4.5-2.

17.14.5 Fail-safety of electric propulsion plant control systems.

17.14.5.1 Electric propulsion plant control systems with the use of processors shall comply with the requirements of Section 7, Part XV "Automation".

17.14.5.2 The loss of power or malfunctioning of any other control and monitoring systems shall not result in loss of propulsion and electric propulsion plant control, ship's steering or azimuth drive.

17.14.5.3 Electric propulsion plant, azimuth drives and their control systems shall have self-check system and an alarm system to detect failures quickly.

17.14.5.4 The most probable failures, e. g. loss of power, wire failure or cable and wire short circuits, etc. shall result in the least critical of all possible new conditions of the ship (fail to safety).

17.15 ELECTRIC COUPLINGS

17.15.1 General.

17.15.1.1 Electric couplings shall be designed so that they may be dismantled without the disassembly of a driving motor or reduction gear. The design and location of couplings shall ensure free access for their maintenance, brush replacement and air gap measurements without dismantling the couplings.

17.15.1.2 Enclosures and end shields shall be made of steel or material of equivalent strength (refer also to 10.1.1).

17.15.1.3 The rotating parts of couplings, as well as their windings shall be designed and secured so

Table 17.14.4.5-1

List of monitored parameters of the electric propulsion plant with AC synchronous, permanent excited and induction electric propulsion motors

Monitored parameter	Limiting value, Max/Min	Local measuring instrument	Alarm, display in the main machinery control room	Load reduction	Automatic "Stop"	Main control station (bridge), group alarm
Electric propulsion motor:						
Lubrication system	Malfunction	Inspection glass	×	×	×	×
Bearing temperature	Max	Thermometer	×			×
Stator winding temperature	Max		×	×		×
Slip rings (synchronous electric propulsion motor)	Malfunction (electric arc)	Inspection hatch	×			×
Water/air cooling system	Malfunction		×			×
Cooling air temperature at the inlet	Max	Thermometer	×			×
Coolant	Leakage		×			×
Speed	Max		×		×	×
Voltage regulation (synchronous electric propulsion motor)	Failure		×		×	×
Insulation resistance for stator and feeder	Min		×			×
Insulation resistance for excitation system and feeder (synchronous electric propulsion motor)	Min		×			×
Transformers:						
Winding temperature	Max		×	×		×
Coolant	Leakage		×	×		×
Cooling system	Malfunction		×			×
Converters:						
Mains	Malfunction		×		Start	×
Cooling system	Malfunction		×	×		×
Power units temperature	Max		× Max1		× Max2	×
Cooling agent flow	Min		×			×
Coolant	Leakage		×			×
Preliminary alarm						×
Accident, failure			×		×	×
Rotor speed and position sensor (synchronous electric propulsion motor)	Malfunction		×			×
Emergency stop (Converter switched off)			×		×	×
Semiconductor fuse	Malfunction		×		×	×
Semiconductor temperature	Max		×	Reduction		×
Voltage (direct current link)	Max		×		×	×
Current (direct current link)	Max		×		×	×
Current at the converter outlet	Max		×		×	×
Electric propulsion plant main, shipboard electrical system:						
Harmonic trap	Accident, damage		×			×

that they cannot be damaged in the event of a sudden stop. Electric couplings shall not cause axial forces. Balance ratio of electric couplings shall meet the requirements of 4.1.2, Part IX "Machinery".

17.15.1.4 The maximum torque under excitation forcing conditions shall not exceed the twofold rated torque of the coupling.

The requirements of the present Chapter also apply to electric couplings fitted in other systems.

17.15.2 Protection and interlocking.

The design of the coupling connection system or the interlock used shall be such that the coupling excitation during the main propulsion engine starting and reversing is prevented.

Where several driving motors operate on a common transmission, in order to prevent the simultaneous start of driving motors rotating in opposite directions, the interlock in the coupling excitation system shall be used.

17.15.3 Electric couplings excitation.

Excitation windings of electric couplings shall be protected against overvoltage.

The excitation circuit of electric couplings shall include:

- .1 a two-pole switch;
- .2 a magnetic field discharging device;
- .3 short-circuit protection.

Table 17.14.4.5-2

List of monitored parameters of the electric propulsion plant with DC electric propulsion motors

Monitored parameter	Limiting value, max/min	Local measuring instrument	Alarm, display in the main machinery control room	Load reduction	Automatic "Stop"	Main control station (bridge), group alarm
Electric propulsion motor:						
Lubrication system	Malfunction	Inspection glass	×	×	×	×
Bearing temperature	Max	Thermometer	×			×
Main pole temperature	Max		×	×		×
Auxiliary pole/compensating winding temperature	Max		×	×		×
Water/air cooling system	Malfunction		×			×
Cooling air temperature at the inlet	Max	Thermometer	×			×
Coolant	Leakage		×			×
Speed	Max		×		×	×
Commutator/brushes	Malfunction (electric arc)	Inspection hatch	×			×
Armature current	Max		×		×	×
Insulation resistance for armature circuit and feeder	Min (earth fault)		×			×
Transformers:						
Winding temperature	Max		×	×		×
Coolant	Leakage		×			×
Cooling system	Malfunction		×			×
Converters:						
Mains	Malfunction		×		Restart	×
Cooling system	Malfunction		×	×		×
Power units temperature	Max		×	×	×	×
Cooling agent flow (direct cooling)	Min		×		×	×
Coolant	Leakage		×			×
Preliminary alarm						×
Accident, failure			×		×	×
Armature speed sensor	Malfunction		×			×
Emergency stop (Converter switched off)			×		×	×
Semiconductor fuse	Malfunction		×		×	×
Electric propulsion plant main, shipboard electrical system:						
Harmonic trap	Accident, damage		×			×

18 ADDITIONAL REQUIREMENTS FOR ELECTRICAL EQUIPMENT DESIGNED FOR A VOLTAGE IN EXCESS OF 1000 V UP TO 15 KV

18.1 GENERAL

18.1.1 The requirements apply to three-phase a.c. systems with the rated voltage in excess of 1 kV where the rated voltage means the voltage between phases.

Unless otherwise specified in this Section, the requirements for design and installation for low-voltage equipment (up to 1000 V) given in the present Part also apply to high-voltage equipment.

18.1.2 Electrical equipment for a voltage over 1000 V shall not be housed in the same casing (enclosure) with low-voltage equipment unless the relevant segregation is provided or appropriate measures ensuring safe access for low-voltage equipment maintenance are taken.

18.1.3 Insulating materials used for electrical equipment shall ensure the insulation resistance of 1500 ohms per 1 V rated voltage, but at least 2 megohms during the unit operation.

18.1.4 For monitoring of insulation status the systems for each feeder insulation monitoring shall be used. Such systems shall show direction to the damaged area and have visible and audible alarm at decreasing of the monitored value below the specified level. It is recommended to complete feeder monitoring systems with portable devices for search of insulation fault location.

18.1.5 At the entrance to special electrical spaces, a warning notice shall be provided indicating the voltage. Enclosures of electrical equipment installed outside special electrical spaces shall be provided with warning notices indicating the voltage.

18.2 SYSTEM DESIGN

18.2.1 Distribution design.

18.2.1.1 The following power distribution systems may be used for three-phase a.c. current high-voltage plants:

insulated three-wire system;

three-wire system with the neutral earthed to the ship's hull through a high-capacity resistor or reactor;

four-wire system with the dead earthed neutral.

18.2.1.2 Configuration of network for ensuring uninterrupted power supply.

The main switchboard design shall provide for the possibility of its separation into, as a minimum, two independent parts by means of a circuit breaker or disconnecter.

Each part of sections shall be connected to, as a minimum, one generator.

Where two independent main switchboards interconnected by cable jumpers are provided, circuit breakers shall be fitted at its both sides. All the duplicated electrical drives shall be supplied from different main switchboards or its split sections.

18.2.1.3 Systems with earthed neutral.

18.2.1.3.1 Neutral points of generators running in parallel may be connected to a common bus before an earthing resistor or reactor fitted in a switchboard or immediately at the generators.

18.2.1.3.2 In case of an earth fault, the leakage current shall not exceed the rated current of the largest generator or the total rated current of a relevant main switchboard section and shall not be less than the triple minimum current required for earth-fault protection activation.

18.2.1.3.3 When the system is energized, at least one neutral earthing point shall be closed. The electrical equipment in systems with a dead earthed neutral connected to the hull through a high capacity resistor or reactor shall bear without damage the single phase-to-earth fault current during the time needed for protection device activation.

18.2.1.4 Neutral opening.

In the neutral wire of each generator, provision shall be made for a disconnecter, which may cut out the neutral from earthing for insulation resistance measurements and generator maintenance.

18.2.1.5.1 All earthing impedances of neutral points shall be connected to the hull. The connection to the hull shall be so arranged that any circulating currents in the earth connections do not interfere with radio, radar, intercommunication and control equipment circuits.

18.2.1.5.2 It is allowed to connect all resistors or reactors to the common earthing busbar, which shall be connected to the ship's hull at least at two points.

18.2.1.6 Divided systems.

18.2.1.6.1 Neutral connections to the hull shall be provided for each split group of main switchboard sections in divided systems with an earthed neutral.

18.2.2 Degrees of enclosures protection.

18.2.2.1 General requirements.

Each part of electrical equipment shall have shielded enclosures corresponding to its location and effecting environmental conditions. The requirements of IEC 60092-201 may be considered as minimum.

18.2.2.2 Electrical machines.

A degree of protection by enclosure for electrical machines shall be at least IP23. The degree of

protection of machines lead boxes shall not be less than IP44.

Motors installed in spaces accessible to unqualified personnel shall have the degree of protection of at least IP4X to prevent touching of live and rotating parts.

18.2.2.3 Transformers.

A degree of protection by enclosure for transformers shall be at least IP23.

Transformers installed in spaces accessible to unqualified personnel shall have the degree of protection of at least IP4X.

The requirements of 18.7.1 apply to transformers having no enclosure.

18.2.2.4 Switchgear, control panels and converters.

A degree of metal enclosures protection for switchgear, control panels, static converter cabinets shall be at least IP32. Panels installed in spaces accessible to unqualified personnel shall have the degree of protection of at least IP4X.

18.2.3 Insulation distances.

18.2.3.1 Air clearances.

Air clearances between live parts with different potentials or between live parts and earthed metal parts or the casing shall not be less than specified in Table 18.2.3.1.

Table 18.2.3.1

Nominal voltage, kV	Minimum air clearance, mm
3 (3,3)	55
6 (6,6)	90
10 (11)	120
15	160

Minimum clearances for intermediate values of working voltages are assumed as for the next larger value of a standard voltage.

Selecting lesser clearance, special high-voltage impulse tests shall be made to confirm admissibility of such an option.

18.2.3.2 Creepage distances.

Creepage distances between live parts with different potentials and between live parts and the hull shall be selected on the basis of national and international standards with due regard to the rated voltage of the system, insulation material and dynamic overvoltage due to transient processes.

18.2.4 Protective devices.

18.2.4.1 Faults on the generator side.

In addition to the types of protection specified in 8.2, generators shall be provided with protection devices against an interphase fault in the cables connecting the generator and main switchboard, and against turn-to-turn faults inside the generator.

When this protection device is activated, the generator shall be shut off from the main switchboard and its excitations shall automatically be removed.

In distribution systems with dead earthed neutral, the earth fault of a generator phase shall also result in the activation of protection.

18.2.4.2 Faults to earth.

18.2.4.2.1 An audible and visual alarm shall be activated in a system at any earth faults.

18.2.4.2.2 Protection automatically disconnecting a faulted circuit at earth faults shall be activated in low-impedance (deadly-earthed) systems.

18.2.4.2.3 In high-impedance earthed systems (systems with a neutral earthed through a high-resistance resistor), where the feeders outgoing from the main switchboard can not be disconnected at an earth fault, the insulation of electrical equipment supplied from these feeders shall be designed for the line voltage of the system.

Notes: 1. The systems to be classified as effectively earthed (low impedance) if a coefficient of earthing is below 0,8, and ineffectively earthed (high impedance), 0,8 and over.

2. The efficient of earthing means a ratio between a voltage "phase — earth" in a healthy, i.e. intact system, and a line ("phase — phase") voltage.

18.2.4.3 Power transformers.

Power transformers shall be protected against a short circuit and overloading with circuit breakers.

Where the transformers are intended for running in parallel, the activation of protection on the primary side shall cause their automatic disconnection on the secondary side as well.

18.2.4.4 Voltage transformers for control systems and instruments.

Transformers intended for supply of control circuits and instruments shall be protected against overloading and short circuits on the secondary side.

18.2.4.5 Fuses.

Protective fuses shall be used for short-circuit protection.

No fuses for overload protection are allowed.

18.2.4.6 Low-voltage systems.

Low-voltage distribution systems (up to 1000 V) supplied from high-voltage transformers (systems) shall be protected against overvoltages associated with the ingress of a high voltage on the secondary (low voltage) side. This may be achieved by:

- earthing of the low voltage system;
- appropriate neutral voltage limiters;
- earthed screen between the primary and secondary windings of the transformer.

18.2.4.7 Protective earthing.

Metal enclosures of electrical equipment shall be earthed by external flexible copper conductors having a cross-sectional area designed for a single-phase short-circuit current, but not less than 16 mm². Earthing wires shall be marked.

Earthing conductors may be connected by welding or by bolts of at least 10 mm in diameter.

18.3 ELECTRICAL MACHINES

18.3.1 Stator windings of generators.

Generator stator windings shall have accessible both phase and neutral ends to ensure the installation of the differential protection.

18.3.2 Temperature detectors.

Electrical machines shall be fitted with built-in temperature detectors in their stator windings to actuate an audible and visual alarm whenever the temperature exceeds the permissible limit.

For built-in temperature detectors, means shall be provided to protect measurement circuits against overvoltage.

18.3.3 Tests.

In addition to the tests required for all electrical machines, high-frequency testing voltage tests, in accordance with IEC 60034-15, of individual phase windings (coils) of the machine shall be provided to demonstrate a satisfactory level of resistance to turn-to-turn faults caused by step-fronted switching surges.

18.3.4 Design.

18.3.4.1 A machine casing, bearing shields, guards of air intakes and outlets shall be made of steel alloys. Aluminium alloys for the above parts are not allowed.

18.3.4.2 A draining arrangement readily accessible for maintenance shall be provided in the lower part of a machine casing for removal of condensate.

Vertically-designed motors shall be fitted on their top with a rigidly secured canopy preventing the ingress of water and foreign objects inside the machine. A lower end shield shall be shaped so as to prevent accumulation of water in way of a bearing.

18.3.4.3 Lead boxes of machines shall be dimensioned so as to ensure:

- necessary insulation distances between current-carrying parts and the casing;
- a sufficient space for arrangement of connecting cable terminations and windings ends.

An individual terminal box shall be provided for instrument current transformers, heating anticondensation elements, temperature detectors, etc.

18.3.4.4 The leads of stator winding phases shall enter a separate terminal box, which is different from the ones for lower voltages, through a sealing gasket.

A separate terminal box may be provided for neutral leads.

Terminals for earthing cable cores shall be provided inside terminal boxes. In this case, a reliable

electrical connection between a machine casing and box body shall be ensured.

18.3.4.5 Motors having the rated power 1000 kW and over shall be fitted with differential protection devices. For this purpose, a separate lead box shall be provided on a motor casing, located on the opposite side from the main box, in which a sufficient space for three current transformers and leads of neutral winding ends shall be provided.

18.3.4.6 Bearings temperature of motors with power of 1000 kW and over shall be monitored by local indicators (devices). Temperature detectors for remote control shall also be provided for each bearing.

18.3.4.7 In order to prevent the harmful effect of bearing currents, the bearing on the side opposite to a drive shall be electrically isolated from a casing. The possibility of measuring insulation resistance of an isolated bearing without its disassembly shall be provided.

18.3.4.8 The design of plain bearings shall provide:

- 1 local indicators of the lube oil level;
- 2 separate pump with a local pipeline, tank, cooler, filter and flow-rate indicator when forced circulating lubrication is used;
- 3 potential fitting of instruments for vibration control, including pertinent cable lines, as well as of instruments for bearing wear measurements;
- 4 potential use of the motor starting interlock when lubrication fails.

18.4 POWER TRANSFORMERS

18.4.1 General.

18.4.1.1 Dry-type transformers shall meet the requirements of IEC 60076-11.

Dry-transformers in use shall have earthed screens between high and low voltage windings.

Liquid-cooled transformers shall meet the requirements of IEC 60076.

Oil-immersed transformers shall, as a minimum, be provided with the following alarms and protections:

- "minimum liquid level" — alarm and automatic trip or load reduction;
- "maximum liquid temperature" — alarm and automatic trip or load reduction;
- "high gas pressure in enclosure" — automatic trip.

18.4.1.2 Transformers located in spaces accessible to unqualified personnel shall have a degree of protection provided by enclosure of at least IP4X.

18.4.1.3 Where the low-voltage side of transformer has an insulated neutral point, a spark fuse shall

be inserted between the neutral point of each transformer and ship's hull.

The fuse shall be rated for not more than 80 % of the minimum test voltage of services fed through the given transformer.

18.4.1.4 The equipment for monitoring the condition of insulation on the lower-voltage side of the unit or for detecting locations of this insulation damages may be connected to the fuse in parallel. This equipment shall not interfere with the reliable operation of the fuse.

18.4.1.5 Effective means (e.g. heating) shall be provided to prevent condensation and moisture accumulation inside the transformers when de-energized.

18.4.1.6 Use of aluminium as material for the transformer windings is permitted provided the following conditions are met:

.1 provision is made for protection of the windings and their outlets from the corrosion in the conditions of the open sea;

.2 provision is made for protection from galvanic corrosion at the joints of the windings with current-carrying parts made from other materials;

.3 joints indicated in **18.4.1.6.2** are accessible for inspection and protected from loosening.

18.5 CABLES

18.5.1 General.

18.5.1.1 Cables shall be constructed in accordance with the requirements of IEC 60092-353 and 60092-354 or other equivalent standards.

18.5.1.2 For three-phase cable systems, triple-core cables with multiwire cores shall be used. The cross-sectional area of the cable conductor for power circuits shall be at least 10 mm².

18.6 SWITCHGEAR AND CONTROLGEAR ASSEMBLIES

18.6.1 General.

Switchgear and controlgear assemblies shall be constructed according to IEC 62271-200 and the following additional requirements.

18.6.2 Construction.

18.6.2.1 Mechanical construction.

18.6.2.1.1 Switchgear shall be of the metal-enclosed type in accordance with the requirements of IEC 62271-200, or of the insulation-enclosed type in accordance with the requirements of IEC 62271-201, or in accordance with the requirements of national standards.

18.6.2.1.1.1 Switchboards shall be locked with a special key other than for lower-voltage switchboards and switchgear. Opening of doors and withdrawal of

separate part shall be possible only after disconnection of the panel or switchboard from the electric network.

18.6.2.1.1.2 Passageways for a switchboard and electrical equipment inspection at least 800 mm wide and 1000 mm wide between the bulkhead and switchboard, and between parallel switchboard sections respectively, shall be provided along the switchboards. Where intended for maintenance, their width shall be increased up to 1000 mm and 1200 mm respectively.

The specified width of these passageways is required irrespective of the applied means of protection against contact, like doors, a net or insulated guardrails.

The doors, continuous bulkheads and net screens shall be at least 1800 mm high.

The perforated bulkheads or net screens shall ensure a degree of protection not below IP2X.

Two insulated guardrails shall be fitted along the switchboard at the heights of 600 mm and 1200 mm.

18.6.2.1.1.3 Live parts of electrical installation shall be located at a distance specified in Table 18.6.2.1.1.3 away from protection guards.

Table 18.6.2.1.1.3

Nominal voltage, kV	Minimum height of passageway, mm	Minimum distances of live electrical parts from various protection guards, mm		
		solid doors and continuous	bulkheads net doors and screens	insulated guardrails
3 (3,3)	2500	100	180	600
6 (6,6)	2500	120	200	600
10 (11)	2500	150	220	700
15	2500	160	240	800

18.6.2.2 Locking facilities.

Withdrawable circuit breakers used in switchboards shall be provided with mechanical locking facilities in both service and disconnected positions. For maintenance purposes, key locking of withdrawable circuit breakers and other equipment and fixed disconnectors shall be provided.

Withdrawable circuit breakers shall be located in the service position so that there is no relative motion between fixed and moving portions.

18.6.2.3 Shutters.

The fixed current-carrying contacts of withdrawable circuit breakers shall be automatically covered by insulating shutters when the circuit breaker is drawn out. Insulating shutters for incoming and outgoing circuits may be done by using colours or labels.

18.6.2.4 Earthing and interphase fault devices.

In order to ensure the safe maintenance of high-voltage switchgear, an adequate number of devices for forced busbar fault and earthing for busbars and outgoing feeders shall be provided.

18.6.2.5 Internal arc classification (IAC).

Switchgears and controlgear assemblies shall be classified according to internal arc classification.

Where switchgear is accessible by authorized personnel only Accessibility Type A is sufficient. Accessibility Type B is required if accessible by non-authorized personnel (refer to IEC 62271-200, Annex AA; AA2.2).

Installation and arrangement of the switchgear and contourgear shall comply with their IAC and arrangement (F — Front side; L — Lateral side; R — Rear side).

18.6.3 Auxiliary supply system.

18.6.3.1 Source of supply.

Where a separate auxiliary electrical or other source of power is required for operation of circuit breakers and other switches, and also for protection devices, in addition to such a main source, a stand-by one, which an energy supply shall be sufficient for at least two operations of all the components, shall be provided.

However, the circuit breaker releases activated due to overload, short-circuit or undervoltage shall be independent of any electrical sources of power.

The requirements does not preclude using the releases activated by an operating voltage, provided that the control of tripping circuits and their supply system integrity (continuity) will be ensured, i.e. if the integrity of the circuits is broken or their supply system is faulty (fails), an alarm will be activated.

18.6.3.2 Number of supply sources.

At least one independent stand-by source of power supply for split main switchboards (refer to 18.2.1.1) for operation of circuit breakers and other switches, in addition to their own supply sources each fed from its own busbar system, shall be provided. Where necessary, an emergency source of electrical power intended for activation of the machinery installation from fully de-energized or dead ship condition may be used for this purpose.

18.6.4 High-voltage tests.

Every main and other switchboards shall be tested by a high voltage of standard frequency. The test procedure and voltage values shall meet the requirements of an appropriate national standard or IEC 62271-200.

18.7 INSTALLATION

18.7.1 Electrical equipment.

18.7.1.1 Where high-voltage equipment is not contained but a special room forms the enclosure of the equipment, the access doors shall be so interlocked that they cannot be opened until the supply is isolated and the equipment earthed down.

At the entrance of the rooms or spaces where high-voltage equipment is installed, caution notes

shall be placed, which indicate danger of high-voltage. The relevant free space shall be provided in the vicinity of high-voltage equipment to prevent significant potential hazard to the service personnel during the technical maintenance. In addition, the distance between the switchboard and the above ceiling/deck shall meet the requirements of internal arc classification in compliance with IEC 62271-200.

18.7.1.2 Electrical equipment shall be in special electrical spaces and shall have a degree of protection at least IP23 (refer also to 18.6).

When justified, the equipment may be installed outside the above spaces provided its degree of protection is the last IP44 and access to current-carrying parts of the equipment will only be possible when the voltage is off and special tools are used.

18.7.1.3 A diagram of connections and a drawing of electrical equipment arrangement shall be available in the special electrical space.

18.7.2 Cables.

18.7.2.1 Cable run laying.

Cables shall not run through accommodation spaces. However, when required due to technological reasons, such laying is allowed in special enclosed transit systems (structures).

18.7.2.2 Segregation.

High-voltage cables shall be segregated from cables for voltage below 1000 V. In particular, they shall not be run in the same cable bunch, nor in the same ducts or pipes, or in the same boxes with cables for a voltage 1000 V and below.

Where high-voltage cables of different voltage ratings are installed on the same cable tray, the insulation distances between the cables shall not be less than those specified for a high-voltage cable as per 18.2.3.1.

18.7.2.3 Installation of cables.

High-voltage cables shall be laid in earthed metallic pipes or metallic ducts, or to be protected by earthed metallic enclosures.

Open installation of cables (on carrying pressed panels) is allowed if they have a continuous metallic armour, which shall be reliable and repeatedly earthed.

18.7.2.4 Cable terminations.

Terminations in all conductors of high-voltage cables shall be effectively covered with a suitable insulating material. In terminal boxes, if conductors are not insulated, phases shall be separated from earth and from each other by other by durable barriers of a suitable insulating material.

High-voltage cables, having a conductive layer between phases to control the electric field within the insulation, shall have terminations, which provide electric stress control.

Terminations shall be of the type compatible with the insulation and jacket material of the cable and to

be provided with means for earthing all metallic shielding components (metallic tapes, wires, etc.).

18.7.2.5 Marking.

High-voltage cables shall be readily identifiable by suitable marking.

18.7.2.6 Tests after installation.

Before putting into service of a new high – voltage cable network or after its updating (repair or additional cables installation), each cable and its accessories (terminations, earthing ends, etc.) shall be tested by a high voltage.

Tests shall be carried out after an installation resistance measurement.

For the cables of a rated voltage (U_o/U) above 1,8/3 kV ($U_m=3,6$ kV) testing of electric strength of insulation shall be performed by a.c. testing voltage in compliance with the Manufacturer's recommendations as follows:

a) during 5 min by phase-to-phase voltage of the system being applied between the cable core and a metal screen/braiding;

b) during 24 hours by nominal voltage of the system.

Or by the d.c voltage being equal to $4U_o$ during 15 min.

For cables with nominal frequency (U_o/U) below 1,8/3 kV ($U_m=3,6$ kV) testing of the electrical strength of insulation is made by d.c. voltage equal to $4U_o$ during 15 min.

where: U_o is rated a.c. voltage of rated frequency for which the cable is intended applicable between the phase wires and earthing and a metal screen;

U is rated a.c. voltage of rated frequency for which the cable was intended applicable between the phase wires;

U_m is maximum voltage value in the high voltage system when the equipment capable for operation.

Upon testing, the cable cores shall be grounded for the certain period of time sufficient for removal of the obtained electric charge.

Then the repeated measurement of cable insulation resistance shall be made.

19 REQUIREMENTS FOR ELECTRICAL EQUIPMENT PROCEEDING FROM SHIP PURPOSE¹

19.1 PASSENGER SHIPS

19.1.1 Supply and signalling.

19.1.1.1 Electric drives of sea-water pumps, air compressors and control-and-signalling devices of automatic sprinkler systems shall be supplied directly from the main and the emergency distribution boards through separate feeders. The feeders shall be connected to an automatic switch fitted near the pump of the sprinkler system. Normally, the switch shall be connected to the feeder from the main distribution board, and in case of supply failure it shall automatically switch over to the supply feeder from the emergency distribution board. At the main and the emergency distribution boards, the switches of the feeders shall be clearly marked off and shall be permanently in the "on" position. No other switches shall be fitted to these feeders.

19.1.1.2 Supply cables of sea-water pumps, air compressors and control-and-signalling devices of automatic sprinkler systems shall not run through machinery casings, galleys and other enclosed spaces of high fire hazard, except where the above devices and machinery are installed in the spaces in question.

19.1.1.3 In saloons, in way of stairs, passages and ladders to the boat deck, the lighting fixtures shall be supplied through two independent feeders at least (refer also to 6.2.3).

19.1.1.4 The supply systems of essential ship gear shall be so designed that a fire in one of the main vertical fire zone would not damage the above service supply systems in another main vertical fire zone. This requirements may be considered satisfied where the main and emergency supply feeders of the services running through any such zone are as distant from each other as possible both vertically and horizontally.

19.1.1.5 General alarm system shall consist of two independent groups: one for passengers and the other for the crew.

A special alarm, operated from the navigation bridge or fire control station, shall be fitted to summon the crew. The alarm may be part of the ship's general alarm system the requirements for which are specified in 7.4.

In passenger ships with a low-power electrical plant or with a number of passengers less than 36, one group of general alarms is permitted.

19.1.1.6 A fixed fire detection and fire alarm system shall meet the following additional requirements:

.1 be capable of remotely and individually identifying each detector and manually operated call point;

.2 one section of automatic and manual detectors shall not be located in more than one main vertical zone;

.3 when the system is required to sound a local audible alarm within the cabins where the detectors are located, means to silence the local audible alarms from the control panel shall not be permitted.

19.1.2 Supply from emergency sources of electrical power.

19.1.2.1 In passenger ships of unrestricted service and of restricted area of navigation **R1**, the emergency sources of electrical power shall simultaneously supply, during 36 hours, the following services:

.1 emergency lighting for:

muster and embarkation stations for boarding life-saving appliances and spaces overboard where life-saving appliances are launched according to 2.3.4 and 2.7.7, Part II "Life-Saving Appliances" of the Rules for the Equipment of Sea-Going Ships;

indicators of exits to the boat deck and notice-plates at the life-saving appliances;

exits from the spaces where a large number of passengers, special personnel or crew members can gather simultaneously;

alleyways, stairways and exits to the open deck in all accommodation and service spaces as well as passenger lift cars;

machinery spaces and generator rooms with their local control stations;

all control stations as well as main and emergency switchboards;

emergency diesel generator space;

wheelhouse;

chartroom and radioroom;

stowage positions for emergency and fireman's outfit and positions where manual fire alarms are fitted; steering gear compartments;

positions of attendance upon emergency fire and bilge pump, sprinkler pump and starting positions of their motors;

helicopter hangars and landing areas;

gyrocompass space;

medical space.

.2 navigation lanterns, lanterns of "Vessel not under command" signal and other lanterns required

¹ The present requirements are additions and amendments to the relevant requirements of Sections 1 to 18.

by Part III "Signal Means" of the Rules for the Equipment of Sea-Going Ships;

.3 radio equipment and navigational equipment according to the requirements of Parts IV "Radio Equipment" and V "Navigational Equipment" of the Rules for the Equipment of Sea-Going Ships;

.4 internal communication, announcing and general alarm systems;

.5 fire detection and alarm systems, fire door control devices and indicators showing the position of fire doors specified in 2.2.3.3, Part VI "Fire Protection";

.6 sound signal means (whistle, gong, etc.), daylight signalling lamps, manual summoning signals and other signals as required under emergency conditions;

.7 one of the fire pumps, a pump of the automatic sprinkler system, an electric-driven pump of the pressure water-spraying system referred to in 3.4.7, Part VI "Fire Protection", as well as electrical equipment used to ensure operation of the high expansion foam fire extinguishing systems referred to in 3.7.3, Part VI "Fire Protection";

.8 emergency bilge pump and equipment essential for operation of remote-controlled bilge valves;

.9 services listed in 7.3.6 and 7.3.8, Part VI "Fire Protection" for Class INF2 and INF3 ships in accordance with classification given in 7.3.2, Part VI "Fire Protection", regardless of area of navigation and tonnage of the ship;

.10 other systems, which operation will be considered by the Register to be vital for ensuring the safety of the ship and persons on board.

The services indicated in 19.1.2.1.3 to 19.1.2.1.6 may be fed from its own accumulator batteries located according to 9.2 and having a capacity sufficient for their supply for a period of 36 hours.

For ships of restricted areas of navigation **R2**, **R2-RSN**, **R2-RSN(4,5)**, **R3-RSN** and **R3**, the period of 36 h may be reduced to 12 h.

19.1.2.2 Emergency sources of electrical power shall ensure the supply of steering gear in accordance with 5.5.6.

19.1.2.3 Emergency sources of electrical power shall supply, for a period of 30 min, the following services:

.1 electrical drives of watertight doors together with their indicators and warning signals. Sequential operation of the doors may be permitted providing all doors can be closed in 60 s;

.2 emergency electric drives of passenger lifts. Passenger lifts may be operated sequentially;

.3 supplementary lighting shall be provided in all cabins to clearly indicate the exit. Such lighting may be connected to an emergency source of power or have a self-contained source of electrical power in each cabin.

19.1.2.4 Where a generator serves as the emergency source of electrical power, it shall be:

.1 driven by an internal combustion engine (refer to 2.2.5, Part IX "Machinery");

.2 automatically started in case of supply failure, and automatically switched over to the busbars of the emergency distribution board; services listed under 19.1.2.7 shall be automatically supplied from the emergency generator. The total time for starting and carrying the board by the generator shall not exceed 45 s;

.3 for an emergency, a transitional source of electrical power shall be provided, which shall be activated immediately upon de-energizing.

19.1.2.5 Where an accumulator battery serves as the emergency source of electrical power, it shall:

.1 operate without recharging and with voltage across its terminals within 12 % of rated voltage during the whole discharge period, where voltage variations across the terminals of accumulator battery connected to an electronic voltage converter are determined by the permissible range of voltage variation across the terminals of the converter;

.2 be automatically connected to the busbars of the emergency distribution board in case of supply failure and supply at least the services listed under 19.1.2.7 during the time stipulated by 19.1.2.1.

19.1.2.6 For the emergency transitional source of electrical power required by 19.1.2.4.3, an accumulator battery shall be used, which shall operate without recharging and with voltage across its terminals within 12 % of rated voltage during the whole discharge period. Voltage variations across the terminals of accumulator battery connected to an electronic voltage converter are determined by the permissible range of voltage variation across the terminals of the converter, which shall not be above values specified in 2.1.3.1.

19.1.2.7 The capacity of the battery serving as transitional source of electrical power shall be sufficient for supplying the services listed below during 30 min:

.1 lighting and necessary navigation lights according to 19.1.2.1.1 and 19.1.2.1.2;

.2 internal communication and announcing systems required in an emergency;

.3 general alarm system, fire detection and alarm systems, control devices of fire doors and indicators showing the position of fire doors specified in 2.2.3.3, Part VI "Fire Protection";

.4 daylight signalling lamps, sound signal means (whistles, gongs, etc.) and other types of signals required under emergency conditions;

.5 arrangements for closing watertight doors, their position indicators and signals warning of their closing. Sequential closing is permitted;

.6 ship's security alarm system and AIS installation required by Part IV "Radio Equipment" and

Part V "Navigational Equipment" of the Rules for the Equipment of Sea-Going Ships.

Services listed under 19.1.2.7.2 to 19.1.2.7.6 may be supplied from their own accumulator batteries, which shall ensure their supply during the time necessary.

19.1.3 Electrically powered low-location lighting (refer to 8.5.5, Part III "Equipment, Arrangements and Outfit").

19.1.3.1 The low-location lighting system shall be connected to the busbars of the emergency switchboard so as to be powered by the main source of electrical power under normal circumstances and also by the emergency source of electrical power when the latter is in operation.

The low-location lighting system shall function at all times.

19.1.3.2 Where an accumulator battery is the emergency source of electrical power, its capacity shall be sufficient for powering the low-location lighting system for at least 60 min.

19.1.3.3 The additional emergency lighting required by 19.3.3 may be accepted to form partly or wholly the low-location lighting system, provided that such system complies with the requirements of 19.1.3.

19.1.3.4 The electrically powered low-location lighting system shall ensure the following minimum standards of luminance:

.1 for luminous surface of the planar source — 10 cd/m^2 , the light band being not less than 15 mm in width;

.2 for the point source — 35 mcd in the directions of approach and viewing, along with that:

the direction of viewing for the sources located on a horizontal plane, i.e. on the deck, shall be within a cone with an angle of 60° , the axis of which is inclined at 30° to the source installation plane (refer to Fig. 19.1.3.4.2-1);

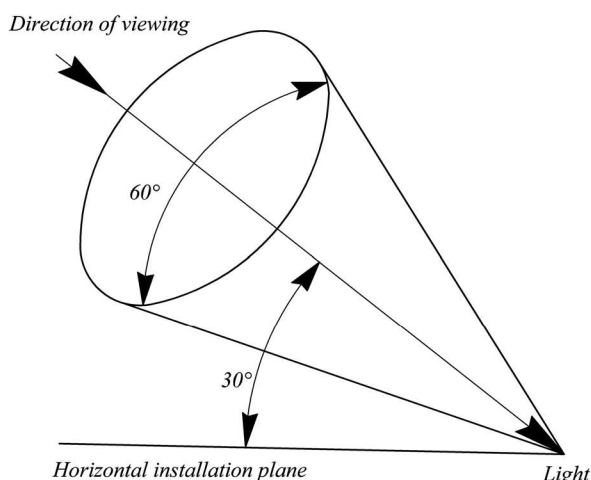

Fig. 19.1.3.4.2-1

the direction of viewing for the sources located on a vertical plane, i.e. on the bulkheads (e.g. for marking of the door handles) shall be within a cone with an angle of 60° , the axis of which is perpendicular to the source installation plane (refer to Fig. 19.1.3.4.2-2);

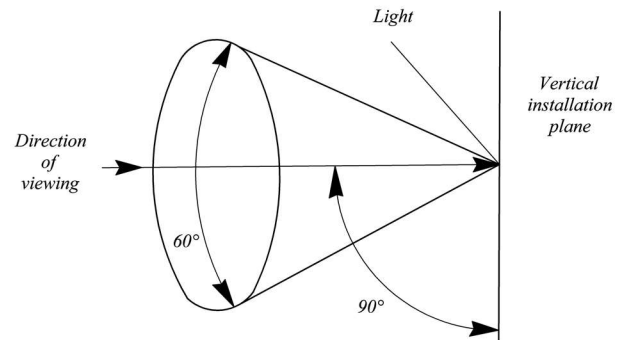

Fig.19.1.3.4.2-2

spacing between sources shall be not more than 300 mm.

19.1.3.5 Power supply of the LLL system shall be such that a failure of any single light or fire in one fire zone or on one deck do not result in lighting and escape route marking in another fire zone being ineffective.

19.1.3.6 Failure or damage, other than short circuit, of any single light, shall not result in loss of visible delineation of the escape route at a length of more than 1 m.

19.1.3.7 The electrical equipment (lights) shall be provided with a minimum degree of ingress protection of IP55.

19.1.4 Additional requirements for passenger ships having a safety centre.

19.1.4.1 Internal communication shall comply with the requirements of 2.2.8.3 and 2.2.8.5, Part VI "Fire Protection".

19.1.4.2 General alarm shall comply with the requirements of 2.2.8.6.4, Part VI "Fire Protection".

19.1.4.3 Indication of closing watertight and fire doors shall comply with the requirements of 2.2.8.6.3, Part VI "Fire Protection".

19.1.4.4 Flooding detection system shall comply with the requirements of 2.2.8.6.8, Part VI "Fire Protection".

19.1.4.5 Indication of closing doors on passenger ro-ro ships shall meet the requirements of 2.2.8.6.7, Part VI "Fire Protection".

19.1.5 Additional requirements for passenger ships having length, as defined in 1.2.1 of the Load Line Rules for Sea-Going Ships, of 120 m or more or having three of more main vertical zones.

19.1.5.1 Steering systems and steering-control systems shall comply with the requirements of 2.2.6.7.2 and 2.2.6.8, Part VI "Fire Protection".

19.1.5.2 Lighting of safety areas shall comply with the requirements of 2.2.6.13.7, Part VI "Fire Protection".

19.1.5.3 Lighting along escape routes, at assembly stations and at embarkation stations of life-saving appliances, shall comply with the requirements of 2.2.7.4.2, Part VI "Fire Protection".

19.1.5.4 Internal communication shall additionally comply with the requirements of 2.2.6.7.6, 2.2.6.8 and 2.2.7.4.4, Part VI "Fire Protection".

19.1.5.5 Flooding detection system shall comply with the requirements of 2.2.6.7.7 and 2.2.6.8, Part VI "Fire Protection".

19.2 OIL TANKERS AND OIL RECOVERY SHIPS

19.2.1 General.

The requirements of the Chapter cover the electrical equipment of oil tankers and oil recovery ships intended for the carriage of petroleum products having a flash point 60 °C and below and petroleum products having a flash point 60 °C and above, which require heating up to a temperature less than 15 °C below the flash point.

The electrical equipment of oil tankers (> 60 °C), oil recovery ships (> 60 °C) and bilge water removing ships (> 60 °C) is covered by the requirements of 19.2.3.2.3.2, 19.2.5, 19.2.6.2 (refer also to 9.6.5, Part VIII "Systems and Piping").

The requirements of this Chapter specify the boundaries of dangerous zones, the division of ship's spaces and areas into zones, the installation of electrical equipment in hazardous spaces and areas in compliance with IEC 60092-502 "Electrical Installations in Ships – Tankers – Special Features".

19.2.2 Distribution of electrical power.

For distribution of electrical power on board the ship, only the following systems may be used:

- .1 two-wire insulated system for direct current;
- .2 two-wire insulated system for single-phase alternating current;
- .3 three-wire insulated system for three-phase alternating current (also for voltage above 1000 but not in excess of 11000 V a.c.);
- .4 three-wire system with neutral earthed through a high-value resistor for voltages above 1000 but not in excess of 11000 V a.c., provided that any possible resulting current does not flow directly through any dangerous spaces and areas.

19.2.3 Dangerous zones, spaces and areas.

19.2.3.1 Classification of dangerous zones.

Zone 0, in which an explosive gas/air mixture is continuously present or present for long periods.

Zone 1, in which an explosive gas/air mixture is likely to occur in normal operation.

Zone 2, in which an explosive gas/air mixture is not likely to occur, and if it occurs it will only exist for a short time.

19.2.3.2 Division of spaces and areas into zones.

19.2.3.2.1 Zone 0:

- .1 internal areas of cargo compartments and tanks, cargo piping and transfer systems of recovered oil;
- .2 open areas lying at a height up to 1 m from oil-covered water surface (for ships operating in the oil spill).

19.2.3.2.2 Zone 1:

- .1 cofferdams and segregated ballast tanks adjoining cargo tanks as well as the forepeak, if served by a system connected to ballast tanks installed in the cargo area;
- .2 enclosed or semi-enclosed spaces containing cargo pumps or cargo piping, provided the latter is not all-welded;
- .3 enclosed and semi-enclosed spaces above the deck of cargo compartments and tanks, which have their bulkheads above or level with the bulkheads of the cargo compartments and tanks;
- .4 enclosed and semi-enclosed spaces immediately above cargo pump rooms and also above vertical cofferdams adjoining cargo compartments and tanks unless separated by a gastight deck and provided with mechanical ventilation;
- .5 areas and spaces other than cofferdams adjoining cargo compartments and tanks and located below cargo compartment and tank top;
- .6 areas and semi-enclosed spaces on the open deck within 3 m of any outlets other than ventilation outlets, cargo tank manholes and hatches, pump rooms and cofferdams adjoining cargo tanks, of cargo valves and cargo piping flanges, as well as areas on open deck within 3 m of cargo vapour outlet (small volumes) and of the pump room ventilation outlets mentioned in 9.7.4 and 12.4.6, Part VIII "Systems and Piping";
- .7 areas on open deck, or semi-enclosed spaces on open deck in the vicinity of any cargo gas outlet arranged according to 9.7.11, Part VIII "Systems and Piping", equipped with high-speed devices to ensure the passage of large volumes of gas or vapour mixture at the rate of 30 m/s at least during cargo loading and ballasting or during discharging, within a vertical cylinder of unlimited height and 6 m radius centred upon the center of the outlet, and within a hemisphere of 6 m radius below the outlet;
- .8 areas on open deck, or semi-enclosed spaces on open deck, within 1,5 m of cargo pump room entrances, cargo pump room ventilation inlet, openings into cofferdams or other zone 1 spaces;
- .9 areas on open deck within spillage coamings and trays surrounding cargo manifold valves and 3 m beyond these, up to a height of 2,4 m above the deck;

.10 areas on the open deck above cargo compartments and tanks over the full breadth of the ship and 3 m fore and aft of their boundary bulkheads up to a height of 2,4 m above the deck as well as enclosed and semi-enclosed spaces within this area. For ships operating in the oil spill, this area is extended to cover the whole length of the ship;

.11 storage spaces for cargo hoses and equipment for collecting spilt oil (oil collectors);

.12 enclosed and semi-enclosed spaces having direct access or other openings into one of the above areas and spaces;

.13 spaces and areas above cofferdams adjoining cargo compartments and tanks, which are not divided by oil- and gastight bulkheads and decks, not adequately ventilated and entered from an upper deck.

19.2.3.2.3 Zone 2:

.1 areas above zone 1 over the full breadth and length of the ship to a height of 6 above the deepest load waterline (for ships operating in the oil spill);

.2 internal areas of cargo compartments and tanks, slop tanks, cargo piping, transfer systems of recovered petroleum products having a flash point > 60 °C and their ventilation systems;

.3 areas on open deck or semi-enclosed spaces 4 m beyond the cylinder and 4 m beyond the sphere with the radius of 6 m defined in 19.2.3.2.2.7;

.4 areas or spaces within 2 m of the areas defined in 19.2.3.2.2.6.

19.2.3.2.4 Spaces and areas not included in zones 0, 1 and 2 are considered safe.

19.2.3.3 Enclosed spaces having direct access to or other openings into areas listed under 19.2.3.2.2.10 are not regarded as dangerous if provision is made for two self-closing gastight doors forming an air lock and, additionally, for mechanical supply ventilation with air suction from locations outside dangerous zones.

19.2.3.4 In the case of ships operating in the oil spill, entrances, ventilation openings (both for suction and discharge) and other openings of safe spaces such as accommodation, service spaces and machinery spaces, control stations and wheelhouse, which have no gastight closures, shall not be located more than 6 m below the deepest waterline and, under all circumstances, shall be outside dangerous zones.

Entrances to safe spaces lying more than 6 m below the deepest waterline or within dangerous zones shall be provided with air locks. In such spaces, openings more than 6 m below the waterline shall bear gastight closures when operating in the oil spill.

19.2.4 Electrical equipment in hazardous areas.

19.2.4.1 Only the following electrical equipment may be considered for zone 0 spaces:

.1 certified intrinsically-safe apparatus of category (*ia*);

.2 simple electrical apparatus and components (for example, thermocouples, photocells, strain gauges, junction boxes, switching devices, included in intrinsically-safe circuits of category (*ia*), not capable of storing or generating electrical power or energy for ignition of explosive mixture even in case of disconnection, short circuit or earth fault in the intrinsically-safe circuit.

19.2.4.2 Only the following electrical equipment may be considered for zone 1 spaces:

.1 any type that may be considered for zone 0;

.2 certified intrinsically-safe apparatus of category (*ib*);

.3 simple electrical apparatus and components (for example, thermocouples, photocells, strain gauges, junction boxes, switching devices, included in intrinsically-safe circuits of category (*ib*), not capable of storing or generating electrical power or energy for ignition of explosive mixture at normal operating conditions;

.4 certified flameproof type (*d*);

.5 certified pressurized type (*p*). In this case automatic shutdown is required when values of overpressure fall below minimum prescribed values;

.6 certified increased safety type (*e*). In this case the electric motors with voltage of 3kV and above require an addition protection such as air purging prior to the start to reduce the risk of spark striking in the air gap;

.7 with compound sealing (*m*) ;

.8 special explosion protection (*s*);

.9 echo sounder transducers and their cables in compliance with the requirements of Part V "Navigational Equipment" of the Rules for the Equipment of Sea-Going Ships, cables of an impressed current cathodic protection system, housed within corrosion-resistant steel pipes with gastight connections up to the upper deck and not located adjacent to a cargo tank bulkhead (refer also to 16.8.4.2);

.10 through runs of cables.

19.2.4.3 The electric motors driving the arrangements located in pump rooms shall be installed in adjacent flameproof spaces (refer also to 4.2.5, Part VII "Machinery Installations"). The electric motors shall be fitted with remote shut-down devices located outside the spaces where the motors are installed and above the cargo tank deck (refer also to 9.4.4, Part VIII "Systems and Piping").

19.2.4.4 Lighting in pump rooms shall be interlocked with ventilation of these spaces in such a way as to ensure the possibility of the lighting switching on with ventilation in operation only. Failure of the ventilation system shall not result in the lighting switching off. Emergency lighting, if fitted, shall not be interlocked with ventilation.

19.2.4.5 Only the following electrical equipment may be considered for zone 2 spaces:

- .1 any type that may be considered for zone 1;
- .2 tested specially, for example type (n) protection;
- .3 the type which ensures the absence of sparks and arcs and of "hot spots" during its normal operation.

19.2.5 Portable electrical equipment used for collecting spilt oil.

19.2.5.1 Portable equipment for collecting and transfer of oil shall be of safe type.

19.2.5.2 Distribution boards and socket outlets for supplying portable oil-collecting and transfer equipment on deck shall be permanently fitted in such a way that a cable connected to them would not pass through door coamings or other closed openings serving as a boundary of dangerous spaces and zones.

The design of such distribution devices and socket outlets shall provide for an interlock that would rule out the possibility of the portable electrical equipment being connected to them when energized and ensure protection from short-circuit currents and overvoltage in each phase.

19.2.5.3 Flexible cables for connection of portable electrical equipment used for collecting spilt oil shall have a metallic braid (screen) covered by an external proof sheathing of an oil-resistant material.

19.2.6 Installation of cables.

19.2.6.1 On the decks of oil tankers and oil recovery ships, cables shall run on flying bridges in suitable conduits (grooves). Single cables may be laid in pipes. Where the flying bridges are within zone 1, cables complying with the requirements of 2.9.11 shall only be installed.

19.2.6.2 When cables are installed in conduits (grooves), the following requirements shall be met:

.1 cables in conduits (grooves) shall be loosely laid in rows on separators of non-metallic materials; in this case, the possibility of lateral displacement of the row (cable) shall be excluded. It is permitted to use methods of fixed pipeless installation of cables (in cable hangers, under clips), which shall be approved by the Register from the viewpoint of the design features; in case of fixed installation cables shall be laid not more than in two rows;

.2 cables shall not be in contact with metal parts of the conduit (groove);

.3 cables shall not be subjected to constant or variable tensions due to deformation of the ship's hull and shall be protected from this deformation, especially in way of detachable or sliding connections between the gangway or platform and superstructures. In way of detachable or sliding connections of the gangway or platform provision shall be made for expansion loops having the inside radius of not less than 10 diameters of the thickest cable;

.4 cables shall be protected from direct exposure to solar radiation, sea waves, oil products carried on board the ship and from mechanical damage;

.5 cables shall be separated from sources of heat by a distance specified in 16.8.4.1;

.6 cables runs on the passageway platform or in pipes inside spaces within zone 1, as well as expansion loops shall not be located below 300 mm from the cargo tank deck;

.7 metal sheaths or armours of cables shall be earthed at both ends. For final subcircuits earthing of the metal sheath may be effected only at the supply end.

19.2.6.3 In systems with voltages specified in 19.2.2.1.4, only cables having copper screens with additional insulation covering may be used. The cross-sectional area of a screen shall be at least the cross-sectional area of a conductor.

19.2.7 Integrated cargo and ballast systems.

19.2.7.1 These requirements are applicable to integrated cargo and ballast systems on tankers, irrespective of the size or type of the tanker.

Within the scope of these requirements, integrated cargo and ballast system means any integrated hydraulic and/or electric system used to drive both cargo and ballast pumps (including active control and safety systems and excluding passive components, e.g. piping).

19.2.7.2 Measures shall be taken to prevent cargo and ballast pumps becoming inoperative simultaneously due to a single failure in the integrated cargo and ballast system, including its control and safety systems.

19.2.7.3 The emergency stop circuits of the cargo and ballast pumps shall be independent from the circuits for the control systems. A single failure in the control system circuits or the emergency stop circuits shall not render the integrated cargo and/or ballast system inoperative.

19.2.7.4 Manual emergency stops of the cargo pumps shall be arranged in a way that they are not cause the stop of the power pack making ballast pumps inoperable.

19.2.7.5 The control systems shall be provided with a duplicate power supply from the main switchboard. The failure of any power supply shall provide audible and visible alarm activation at each pump control location.

19.2.7.6 In the event of failure of the automatic or remote control systems, a secondary means of control shall be made available for the operation of the integrated cargo and ballast system. This can be achieved by manual overriding and/or redundant arrangements within the control systems.

19.3 SHIPS INTENDED FOR CARRIAGE OF MOTOR VEHICLES WITH FUEL IN THEIR TANKS INCLUDING COMPRESSED HYDROGEN OR NATURAL GAS FOR THEIR PROPULSION

19.3.1 General.

19.3.1.1 The requirements of the present Chapter are applicable to electrical equipment of holds and other spaces and areas intended for the carriage of motor vehicles with fuel in their tanks necessary for their propulsion.

19.3.1.2 The holds and spaces specified in 19.3.1.1 belong to the category of dangerous spaces and zones.

19.3.1.3 Cables shall be protected against mechanical damage. Cables installed horizontally shall be positioned at a distance not less than 450 mm above the continuous deck or platform preventing a free propagation of gases in the downward direction. The sealings where cables penetrate bulkheads and deck shall be gastight.

19.3.1.4 Electrical equipment installed in ventilation ducts shall be of the following safe types: increased safety (*Exe*) or with flameproof enclosure (*Exd*) and be able to operate in the explosive gas environment and comply with IIC (compressed hydrogen) or IIA (compressed natural gas) gas mixture.

19.3.1.5 The lighting system in holds and spaces specified in 19.3.1.1 shall be arranged at least in two groups, each supplied separately from an independent circuit.

19.3.2 Installation of electrical equipment in holds and spaces intended for carriage of motor vehicles with fuel in their tanks in passenger ships and ferries.

19.3.2.1 In holds and compartments, in spaces located at a height of more than 450 mm above the cargo deck or platform preventing free penetration of gases downwards, it is allowed to install electrical equipment:

with the degree of protection at least IP55 provided the ventilation system ensures at least 10 air changes per hour;

specially designed for use in Zone 2.

19.3.2.2 In holds and spaces above the bulkhead deck, in zones less than 450 mm above the deck or platform preventing, a free propagation of gases in the downward direction, electrical equipment installed shall be of the following safe types: intrinsically safe (*Exi*), with pressurized enclosure (*Exp*), with flameproof enclosure (*Exd*) or increased safety (*Exe*).

19.3.2.3 In holds and spaces below the bulkhead deck all the electrical equipment shall be of the following safe types: intrinsically safe (*Exi*), with pressurized enclosure (*Exp*), with flameproof enclosure (*Exd*) or increased safety (*Exe*).

19.3.3 Special requirements for passenger ships having ro-ro cargo spaces.

19.3.3.1 In passenger ships with roll-on/roll-off cargo spaces or special-category spaces as mentioned under 1.5, Part VI "Fire Protection", apart from emergency lighting required by 19.1.2.1.1, additional emergency lighting shall be provided in all public spaces and corridors, that shall serve for 3 hrs at least under any heel of the ship and when all other electrical power sources fail.

This lighting shall make the escape routes clearly visible (or ensure an illumination intensity of 0,5 lx). Any damage to a lighting fixture shall be clearly visible.

19.3.3.2 As electrical power sources for this additional lighting, accumulator batteries shall serve fitted in lighting fixtures, continuously recharged from the emergency distribution board and replaced within the period established by the manufacturer with regard to their service conditions.

19.3.3.3 In each corridor of crew spaces, in crew recreation rooms and in each space where the crew members generally work, a hand lamp (lantern) shall be provided supplied from an accumulator unless additional emergency lighting stipulated by 19.3.3.1 and 19.3.3.2 is installed in the space.

19.3.4 Installation of electrical equipment in holds and spaces intended for carriage of motor vehicles with fuel in their tanks in cargo ships.

19.3.4.1 In holds and compartments, in spaces located at a height of more than 450 mm above the cargo deck or platform preventing free penetration of gases downwards, it is allowed to install electrical equipment:

with the degree of protection at least IP55 provided the ventilation system ensures at least 10 air changes per hour;

specially designed for use in Zone 2.

19.3.4.2 In holds, spaces and zones less than 450 mm above the cargo deck or platform preventing a free propagation of gases in the downward direction, electrical equipment installed shall be of the following safe types: intrinsically safe (*Exi*), with pressurized enclosure (*Exp*), with flameproof enclosure (*Exd*) or increased safety (*Exe*).

19.4 SPECIAL PURPOSE SHIPS

19.4.1 Supply of essential services.

In special purpose ships carrying more than 60 persons, the power supply of essential services shall comply with 19.1.1.4.

19.4.2 Emergency sources of electrical power.

19.4.2.1 In special purpose ships carrying not more than 60 persons, the emergency source of electrical power shall comply with 9.3.

Ships having a length above 50 m shall additionally comply with 19.1.2.3.1.

19.4.2.2 In ships carrying more than 60 persons, the emergency source of electrical power shall comply with 19.1.2.

19.4.3 Electrical equipment in storerooms for explosives.

19.4.3.1 Except for lighting fixtures in glass hoods and protection gratings and cables in gastight pipes, no electrical equipment shall be installed in storerooms for explosives specified in 2.1.5.3, Part VI "Fire Protection".

19.4.3.2 Switches of lighting circuits shall be fitted outside storerooms for explosives and shall be provided with light signals to indicate the presence of voltage in the lighting fixtures.

19.4.3.3 In storerooms for explosives, the devices for connection of portable electrical equipment to the ship's mains shall be provided with nameplates indicating the rated electrical parameters and shall have a protective enclosure not below IP56 type.

19.4.4 Ships used for processing the living resources of the sea and not engaged in their catching.

19.4.4.1 Survey of electrical equipment.

In addition to the requirements of 1.3.2, the electrical equipment of processing machinery (catch processing) is subject to survey on board the ship (refer also to 1.3.2.4.1).

19.4.4.2 Survey during manufacture of electrical equipment.

The electrical equipment of processing machinery specified in 19.4.4.1 is subject to survey during manufacture in addition to that listed in 1.3.3.1. Use of electrical equipment not fully complying with the requirements of Sections 1 — 18 is permitted.

19.4.4.3 Structural requirements and protection of electrical equipment of processing machinery and refrigerating plants.

19.4.4.3.1 The electrical equipment installed in catch processing spaces shall be resistant to seawater and fish processing products influence or shall be adequately protected against it.

19.4.4.3.2 The electric motors of the processing refrigerating compressors, fans of the refrigerated holds and freezing apparatus and, in well-grounded cases, the electrical equipment of other processing machinery shall be provided with heating arrangements to maintain a temperature which is at least by 3 °C higher than the ambient temperature.

19.4.4.3.3 Distribution gear and start, control and protection devices of electrical equipment specified in 19.4.4.3.1 shall be installed in special electrical spaces.

19.4.4.3.4 Cables installed in spaces subjected to prolonged influence of salt and other products of fish processing shall be provided with sheaths resistant to such influence or be adequately protected.

19.4.4.4 Composition and capacity of main electrical power source.

19.4.4.4.1 Determination of the composition and capacity of the main source of electrical power shall be determined with regard to the following operating conditions of the ship:

running conditions;

manoeuvring;

in case of fire, hole in the ship's hull or other conditions affecting the safety of navigation, with the main source of electrical power in operation;

processing.

19.4.4.4.2 The capacity of generators composing the main electrical power source shall be such that if any of them fail, the rest will ensure power supply of electrical equipment under conditions specified in 19.4.4.4.1, as well as minimal habitable conditions to persons on board.

19.4.4.5 Distribution of electrical power.

19.4.4.5.1 Where the main electrical power source incorporates shaft generators not intended for operation in parallel with the independently driven generators, the machinery and systems ensuring propulsion, manoeuvrability and safety of navigation shall be supplied from the busbars of independently driven generators, while the electrical equipment of processing refrigerating plant and machinery shall be supplied from the busbars of shaft generators.

19.4.4.5.2 The electric drives of processing refrigerating compressors shall be supplied by separate feeders from the busbars of the main switchboard. It is admissible for these drives to be fed from a separate switchboard supplied by two feeders connected to different sections of the main switchboard.

19.4.4.5.3 Electrical circuit for supplying switchboards of the processing machinery (catch processing) shall be separated electrically (galvanically) from the ship's mains.

19.4.4.5.4 If provision is made for electrical power transmission to other ships, a power transmission switchboard separated electrically (galvanically) from the ship's mains shall be installed.

19.4.4.5.5 Where portable tools and movable mechanization facilities not permanently installed are supplied from a circuit of more than 50 V, a safety isolation device in combination with a separating transformer shall be used for each consumer. Such device shall interrupt power supply if the hull leakage current exceeds 30 mA.

19.4.4.6 Lighting.

19.4.4.6.1 Catch processing spaces and refrigerating machinery rooms shall be illuminated by stationary lighting fixtures, which shall be supplied and arranged in accordance with 6.2.3.

19.4.4.6.2 Fish storage holds shall be illuminated with stationary lighting fixtures, which shall be supplied in accordance with 6.2.7.

19.4.4.7 Signalling.

A "Man-in-Hold" signal push-button shall be located inside the refrigerated holds at each exit to actuate signal at the wheelhouse or another permanent attended space.

19.4.4.8 Emergency electrical installations.

19.4.4.8.1 The emergency source of electrical power shall comply with the requirements of 9.3.

19.4.4.8.2 In addition to the requirements of 9.3.1.1, the emergency source of electrical power shall supply the emergency lighting for the catch processing spaces and the exits therefrom as well as for the deck in way of fishing machinery.

19.4.4.8.3 Where a generator is used as the emergency source of electrical power, an emergency transitional source of electrical power (accumulator battery) shall be provided, the capacity of which shall be sufficient to supply the consumers specified in 9.3.7 and 19.4.4.8.2 during 30 min.

19.5 CONTAINER SHIPS

19.5.1 General.

The requirements of the Chapter are applicable to the electrical equipment of ships intended for the carriage of thermal containers.

19.5.2 Supply and distribution of electrical power.

19.5.2.1 As the rated power of electrical equipment of thermal containers their prescribed power shall be taken. The consumed power of the electrical equipment of thermal container shall not exceed 15 kW (18,75 kVA) under rated operating conditions.

19.5.2.2 The overload protective device of sources of electrical power prescribed in 8.2.3 shall ensure disconnection of thermal containers from the main switchboard in the last turn (refer also to 20.2.1).

19.5.2.3 The electrical circuit supplying the equipment of thermal containers shall be separated from the ship's mains by transformers with separate windings, fed from the main switchboard.

19.5.2.4 The electrical installations of thermal containers shall be fed from special distribution gear energized by separate feeders.

19.5.2.5 Socket outlets installed in cargo holds or on open decks in areas of stowage of thermal containers shall be supplied by separate outgoing feeders from the special distribution gear (switchboards) specified in 19.5.2.4 and 19.5.3.3.

19.5.2.6 The electrical circuit of socket outlets intended for supply of the electrical installations of thermal containers shall be rated for 220/380 V voltage at 3-phase alternating current, 50 Hz in

frequency, or for 240/440 V voltage at 3-phase alternating current, 60 Hz in frequency.

19.5.2.7 For each isolated network of sockets monitoring of insulation resistance shall be provided (refer to 2.11).

19.5.3 Distribution gear and transformers.

19.5.3.1 The distribution gear (switchboards) of thermal containers, electrical converters, if any, and transformers with separate windings shall be installed in special electrical spaces.

19.5.3.2 The secondary winding of transformers with separate windings shall have an isolated zero point.

19.5.3.3 Each distribution gear (switchboard) shall be equipped with appliances, which ensure:

- .1 visual signalling to indicate the presence of voltage;
- .2 connection and disconnection of each outgoing feeder supplying the socket outlets;
- .3 short-circuit protection at the outgoing feeders supplying the socket outlets;
- .4 measuring of insulation resistance with visible and audible alarm at the main machinery control room at decreasing of the controlled value below the specified level.

19.5.4 Socket outlets.

19.5.4.1 In holds containing thermal containers it is allowed to install socket outlets used only for power supply of containers with the degree of protection not less than IP55 type, and on open decks — IP56 type.

When the electrical systems of remote control over temperature, humidity, ventilation and other characteristics of thermal containers are used, it is permitted to install additional socket outlets for connection of these control devices in holds or on decks.

19.5.4.2 Socket outlets for power supply of the electrical equipment of thermal containers shall, in addition to requirements of 6.6, be fitted with an isolating switch interlocked so that the plug cannot be inserted or withdrawn while the switch is in the "on" position. A nameplate indicating the voltage shall also be fitted.

19.5.4.3 The electrical installation of thermal containers shall be supplied from the ship's mains at the direct sequence of phases *A(R)*, *B(S)*, *C(T)* according to the scheme given in Fig. 19.5.4.3.

19.5.4.4 Socket outlets intended for supply of the electrical installations of thermal containers shall be rated at the following currents:

- 63 A for voltage of 220 V, 50 Hz or 240 V, 60 Hz;
- 32 A for voltage of 380 V, 50 Hz or 440 V, 60 Hz.

19.5.4.5 Socket outlets shall be designed so as to prevent connection of plugs rated for one voltage to socket outlets rated for another voltage.

19.5.4.6 Design and dimensions of plugs and sockets shall correspond to international standards.

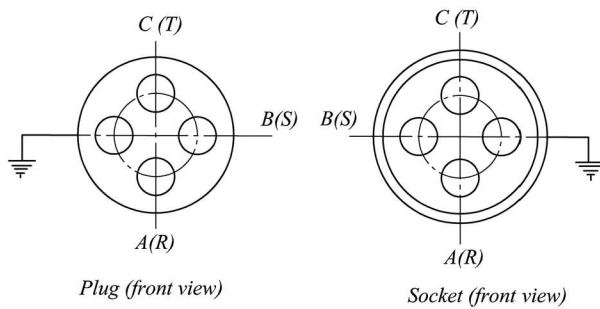

Fig. 19.5.4.3

19.5.5 Protection earthing.

The receptacle intended for connection of the earthing conductor in the flexible cable of the thermal container shall be grounded through the earthing conductor in the supply feeder, where the distribution gear (switchboard) is installed for supply of socket outlets of thermal containers.

19.6 CATAMARANS

19.6.1 In each hull of the ship at least one generator being a part of the main source of electrical power shall be provided.

19.6.2 In each hull of the ship, a main distribution board shall be installed. One of the boards may be installed above the bulkhead deck.

19.6.3 The busbars supplying the ship hulls shall be sectioned.

19.6.4 The emergency services of each hull shall be supplied from the emergency source of electrical power through separate feeders.

19.6.5 The disconnecting switches of electrical equipment specified in 5.7.1, 5.7.2, 5.8.1, 5.8.2 and 5.8.3 shall be grouped separately for each hull.

19.7 FLOATING CRANES AND CRANE SHIPS

19.7.1 Where systems similar to those mentioned in Section 17 are used for crane machinery of floating cranes and crane ships, the requirements of this Section being also applicable to the electric drives of crane machinery, such systems fall, so far as practicable, under the relevant requirements of the present Chapter.

19.7.2 For self-driven floating cranes, the capacity of the main source of electrical power shall be sufficient for the selective operation of the crane both underway and during cargo-handling operations.

19.7.3 Accumulator rooms, accumulator boxes and spaces containing emergency sources of electrical

power may be located below the bulkhead deck, provided all the requirements of 9.2 and 13.2 are satisfied.

19.7.4 To produce sound signals during cargo-handling operations, a sound-signal means shall be fitted on the crane, activated from the operator's cabin.

19.8 FLOATING DOCKS

19.8.1 General.

The requirements of the present Chapter cover the electrical equipment of steel floating docks in addition to the relevant requirements set forth in Sections 1 to 18.

19.8.2 Survey of electrical equipment.

19.8.2.1 In addition to requirements of 1.3.2.1, the following kinds of equipment, systems and devices are subject to survey on board the floating dock:

.1 electric drives and their systems of control and monitoring of the mechanisms ensuring submersion and emersion of the dock;

.2 earthing of the docked ship.

19.8.2.2 All kinds of electrical equipment used in steel floating docks and listed under 1.3.3.1 and 19.8.2.1 are subject to survey during manufacture. For machinery and gear of non-autonomous docks, it is permitted to use the electrical equipment not fully complying with the requirements of Section 1 — 18.

19.8.3 Protective enclosures of electrical equipment.

Protective enclosures of the electrical equipment shall be in compliance with Table 2.4.4.2 considering that dry compartments of the dock wing walls refer to the spaces of increased humidity, and dry compartments of pontoons, tunnels in pontoons and other similar spaces refer to the extra humid category.

19.8.4 Earthing.

19.8.4.1 Each docked ship shall be earthed to the dock hull through at least two special flexible cable connectors having a cross-sectional area not less than 70 mm² each, and devices for connection thereof to the dock hull shall be provided at the dock.

19.8.4.2 To connect the dock hull to the shore earthing system, it is necessary to provide at least two flexible copper cables, having a cross-sectional area not less than 70 mm² each, and also a device for connection of these cables to the dock hull.

No metal earthing of the dock hull is allowed if a system of cathodic protection from corrosion is applied, and circuits of the dock are electrically separated from the shore circuits.

19.8.4.3 All sections of the dock hull, pontoons, wing walls and similar structures shall be electrically connected by reliable means.

19.8.5 Number and output of sources of electrical power.

19.8.5.1 Main sources of electrical power for docks may be as follows:

.1 for autonomous docks — intrinsic generators;

.2 for non-autonomous docks — shore electrical power system.

19.8.5.2 At least two generators and, in addition, a shore electrical power system, if necessary, shall be provided as main sources of electrical power on autonomous docks.

For non-autonomous docks it is allowed to use only a shore electrical power system.

19.8.5.3 The power of main generators of autonomous docks or the power available from a shore electrical power system shall be sufficient to ensure the following operating conditions of the dock:

submersion of the dock;

docking of the ship;

emersion of the dock;

emergency condition;

other conditions in accordance with the dock's purpose.

19.8.5.4 The power of main generators of the autonomous dock shall be such that in case of failure of any generator the rest of the generators ensure safe submersion and emersion of the dock and also docking and undocking of ships.

19.8.6 Distribution of electrical power.

19.8.6.1 The following systems of electrical power distribution are allowed for use in docks in addition to those specified in 4.1.1:

.1 three-phase four-wire alternating current system with earthed neutral wire;

.2 one-wire system, both alternating and direct current, with dock's hull return only for welding circuit (refer also to 19.8.4), and also for devices of monitoring and measurement of insulation resistance.

19.8.6.2 In addition to 4.3.1 the following consumers shall be supplied by separate feeders from the main switchboard busbars energized directly by the generators proper or through the transformer, or by the shore electrical power system:

.1 system of monitoring, signalling and control of the dock submersion and emersion;

.2 switchboards for electric drives of the ballast system sluice valves associated with safe operation of the dock;

.3 switchboards for supply of welding outfit;

.4 switchboards for supply of the docked ship.

19.8.6.3 Essential consumers and electric drives of machinery situated at the wing wall where no

source of electrical power is installed shall be supplied from the switchboard located therein. This switchboard shall be considered as a separate part of the main switchboard and shall be fed from the main switchboard by two feeders. The cross-section of each feeder shall be sufficient for supply of the wing wall essential consumers in case of failure of one feeder. The supply feeders shall run between wing walls in different spaces if it is permitted by the dock design.

In separate cases, installation of both feeders in one space may be allowed.

19.8.6.4 Signal marker lights may be supplied from lighting switchboards.

19.8.6.5 In case of high-voltage electrical power supply of the non-autonomous dock from the shore electrical power system, in addition to the high-voltage feeder a device shall be fitted for connection of the low-voltage supply feeder. This device shall be designed for continuous transmission of electrical energy required at the idle dock when no repairs are carried out. In this case, provision shall be made for continuous supply of at least one electric drive of maximum capacity fire pump when fully loaded and also for supply of all electric motors of sluice valve drives and lighting of main spaces.

When high-voltage electrical power is supplied to the non-autonomous dock by two independent feeders, a low-voltage supply feeder need not be provided.

19.8.6.6 When the dock is supplied from the shore low-voltage electrical power system, it is required to provide two feeders and two devices for reception of electrical power, one of them supplying the consumers specified in 19.8.6.2 and the other — at least the consumers referred to in 19.8.6.5.

19.8.6.7 Arrangement and design of devices for connection of cables used for power supply from the shore electrical power system shall be such as to ensure:

.1 installation of cables at an adequate distance from one another to prevent simultaneous damage of high-voltage and low-voltage feeders;

.2 absence of mechanical stresses in cables during submersion and emersion of the dock;

.3 prevention of transmission of mechanical stresses to the terminals intended for connection of cables or wires.

It is recommended that the devices for reception of electrical power from the shore electrical power system shall be located on different wing walls of the dock.

19.8.6.8 A bright and clear warning inscription indicating the voltage shall be made on the hull in a prominent position or on the door of the external supply switchboard.

19.8.6.9 The maximum permissible level of the short-circuit power shall be determined for each dock,

which may be supplied from the shore electrical power system. This level shall be marked on the warning inscription of the external supply switchboard.

19.8.6.10 The docked ships shall be fed from the stationary supply switchboards installed in the dock.

19.8.6.11 Each supply switchboard of the docked ship shall be fitted with:

.1 switchgear and protective devices, terminals or plug and socket connectors for flexible cables connected to the docked ship. All the terminals of the switchboard shall bear a mark indicating a phase or pole;

.2 a pilot lamp indicating the presence of voltage across switchboard terminals;

.3 a nameplate indicating the nominal voltage, nature of current, its permissible value and frequency.

19.8.6.12 At the supply switchboard of the docked ship provision shall be made for the device for fastening the ends of the flexible cable feeding the docked ship.

19.8.6.13 Cross-sectional area of the flexible supply cable of the docked ship shall be chosen for rated current of the protection setting fitted in the outgoing feeders of the supply switchboard of the docked ships.

19.8.7 Transformers.

In floating docks one transformer of adequate power may be used for supply of the lighting circuit and circuits of essential consumers. In this case, it is recommended to provide for possible reserve supply of these consumers from the transformer intended for feeding the docked ships.

19.8.8 Lighting.

In addition to provisions of 6.6.1, socket outlets for portable lighting fixtures shall be installed at least:

in dry compartments of wing walls where equipment and outfit for the system of submersion and emersion of the dock is located;

in spaces of safety deck where the equipment for the system of submersion and emersion of the dock is located;

in the space where the central control console of the dock submersion and emersion is located;

in the area of location of the mooring machinery electric drives.

19.8.9 Service telephone communication.

19.8.9.1 In the absence of other types of voice communication provision shall be made for telephones of the ship's control group, which ensure clear two-way communication between the following spaces:

main machinery control room — warping capstans;

main machinery control room — emergency diesel-generators space;

main machinery control room — main switchboard space;

main machinery control room — main diesel generator space;

main machinery control room — high-voltage transformer space;

main machinery control room — spaces of location of hand drives for sluice valves of the dock submersion and emersion system;

main machinery control room — fire-extinguishing station.

Besides, two-way independent voice communication shall be provided between the main machinery control room and machinery space.

19.8.9.2 In docks provision shall be made for connection of at least one telephone set to the shore telephone system.

19.8.10 General alarm system.

General alarm system shall be actuated from the main machinery control room and from the space intended for the personnel on watch, if such a space is provided.

19.8.11 Installation of cables.

19.8.11.1 If the pontoon deck is illuminated with lighting fixtures of submersible type and if the cables used are not light, they shall run to the lighting fixtures in water- and gastight pipes.

The pipes and their packings shall be selected with regard to operation under pressure not less than the permissible pressure of submersible lighting fixtures.

19.8.11.2 On special agreement with the Register, cables may be installed on tray plates (saddles) welded directly to the dock plating.

19.8.12 Distribution of electrical power and cabling with the use of one-wire system.

19.8.12.1 Relevant terminals of sources and consumers of electrical power shall be reliably connected to the dock hull. This connection shall not be made in pipelines, tanks and cylinders containing compressed gases, petrol and oil.

19.8.12.2 For direct-current circuit the insulated wire shall be connected to the positive poles and terminals of sources and consumers of electrical power.

Instruments, switchgear and protective devices shall be set to the positive pole.

19.8.12.3 Conductors used for connection of terminals of the electrical equipment and the dock hull shall be equal in cross-sectional area to the conductors isolated from the hull.

19.8.12.4 Points of connection of conductors to the steel hull of the dock shall be situated in areas and positions readily accessible for control and maintenance of contacts.

These points shall be located on structures, which are reliably joined by welding to the dock hull.

19.8.12.5 Working earthing conductors shall be joined in such a manner that reliable electrical connection to the hull is ensured.

It is recommended to use high-power busbars, which are connected to the dock hull in several points.

19.8.12.6 Regardless of the system of electrical power distribution used for welding circuit, the welding station in the docked ship shall be supplied by two-wire system from the welding circuit of the dock.

Hull return system of the docked ship is not permitted.

19.8.12.7 When carrying out welding operations on the hull of the docked ship, a cable with a potential opposite to that of the electrode shall be connected to the hull as close to the part being welded as possible.

19.8.13 Busbar conduits.

19.8.13.1 The application of busbar conduits is allowed for floating docks. The degree of protection of busbar conduits depending on the place of installation shall comply with the requirements of 2.4.4.2.

19.8.13.2 Busbar conduits shall be designed for adequate load and shall withstand, along with insulators and holders, mechanical stresses resulting from short-circuit current directly at busbars.

19.8.13.3 At alternating current exceeding 1500 A, provision shall be made for reduction of the current loss in busbar holders, fixtures, insulators and structures which results from the influence of magnetic fields.

19.8.13.4 All protective devices and switchgear connected immediately to the busbar conduit shall be installed in places accessible for inspection and repair.

Cables and busbars connecting the protection devices and the busbar conduit shall not be more than 2 m in length.

19.8.13.5 Busbar conduits with the degree of protection IP20 and below shall be installed at a height not less than 2,5 m above the floor level.

19.8.13.6 Warning inscriptions indicating the voltage shall be made on the protective enclosure of the busbar conduit at 3 to 5 m intervals throughout the whole length.

19.8.14 Emergency electrical installations.

19.8.14.1 Each floating dock shall be provided with an emergency source of electrical power ensuring power supply of all the necessary consumers for not less than 3 hours.

19.8.14.2 Emergency source of electrical power shall ensure supply of consumers as per 9.3.1, which are installed on board the dock, and also supply of the following consumers:

.1 electrical drives essential for sluice valves of the system of the dock submersion and emersion (at least 2 closings and openings of the sluice valves);

.2 indication and control circuits of the system of the dock submersion and emersion;

.3 command service communication.

19.8.14.3 If the emergency source of electrical power is a diesel generator with an automatic starting system, provision shall be made for local starting of the diesel generator.

19.8.14.4 The emergency diesel generator space shall be located above the margin line of the dock and be easily accessible from the open deck.

19.8.14.5 All the emergency consumers shall be supplied from the emergency switchboard.

In well-grounded cases, the emergency diesel generator and emergency switchboard may be installed in different spaces, and also one section of the main switchboard may be used as an emergency switchboard, provided the main switchboard is located above the level of the margin line of the dock.

19.8.15 Electric drives of submersion and emersion system of the dock.

19.8.15.1 Electric drives for sluice valves of the submersion and emersion system shall not hinder manual opening and closing of sluice valves. Interlocking device shall be also provided to prevent the electric drive from operation in case of sluice valve change-over to manual control.

19.8.15.2 Electric drives for sluice valves shall be fitted with local and remote-controlled (in the main machinery control room, etc.) indicators of sluice valve limit positions. For electric drives of sluice valves intended for water distribution in the pontoon compartments it is also recommended to provide for devices indicating the extent to which the sluice valve is open.

19.8.15.3 For sluice valves intended for water distribution in the pontoon compartments it is recommended to provide for separate control of each sluice valve, as well as for group control of port and starboard sluice valves.

19.8.15.4 Control circuit for electric drives of the drain (ballast) pump shall provide for local and remote control from the main control station with indication of the pump operation or control of electric motor load on the ammeter.

19.8.16 Connection of electrical power supply sources.

When generators of the autonomous dock or transformers of the shore power supply are connected directly to the distribution busbar conduit, and the main switchboard is not installed, provision shall be made for a common control desk fitted with control gear for circuit breakers of generators or transformers and with instruments and devices of control, signalling and protective systems.

These instruments and devices are listed in 4.6.

19.8.17 High-voltage electrical installation of the dock.

19.8.17.1 High-voltage electrical installation of the dock shall comply with the requirements of

national standards and rules applicable to the shore electrical installations.

19.8.17.2 High-voltage electrical installation of the dock shall be located in separate special electrical spaces.

19.9 BERTH-CONNECTED SHIPS

19.9.1 For berth-connected ships, the following sources may be used as main sources of electrical power:

- generators;
- shore electrical power system.

19.9.2 On independent berth-connected ships, provision shall be made for at least two generators as main sources of electrical power.

In addition, the ship mains may be supplied from the shore electrical power system.

Berth-connected ships that are not independent may be supplied from the shore electrical-power system only.

19.9.3 On independent berth-connected ships, the power of generators of the main power source or the power supplied by the shore electrical power system shall be sufficient for the operation of services in accordance with the ship purpose, in case of fire, hull leakage or other circumstances adversely affecting the safety of the berth-connected ship while the main source of electrical power is in operation.

19.9.4 The main generator power of an independent berth-connected ship shall be sufficient to ensure operation in accordance with 19.9.3 in the case of failure of any of the generators.

19.9.5 In floating hotels and hostels, power supply and signalling functions of essential systems and gear shall be effected in conformity with 19.1.1.1 to 19.1.1.4.

The side, bow and stern lights may be supplied from lighting switchboards.

19.9.6 Each floating hotel or hostel shall be provided with an independent emergency source of electrical power to ensure the operation of services in accordance with 19.1.2.1 during 12 h, as well as the operation of services in accordance with 19.1.2.3 during 30 min.

19.9.7 As regards the automatic starting of the emergency source of electrical power and provision of an emergency transitional source in floating hotels and hostels, the requirements of 19.1.2.4 to 19.1.2.7 shall be complied with.

19.10 FISHING VESSELS

19.10.1 Survey of vessel's electrical equipment.

19.10.1.1 In addition to the requirements of 1.3.2 the following kinds of equipment, systems and devices are subject to survey on board the ship (refer also to 1.3.2.4.2):

- .1 electrical equipment of fishing machinery;
- .2 electrical equipment of processing machinery (catch processing).

19.10.2 Survey during manufacture of electrical equipment.

The electrical equipment specified in 19.10.1.1 is subject to survey in addition to that listed in 1.3.3.1. The use of electrical equipment of general purpose industrial production specified in 19.10.1.1.2 not fully complying with the requirements of Sections 1 — 18 is permitted.

19.10.3 Structural requirements and protection of electrical equipment of fishing and processing machinery.

19.10.3.1 The electrical equipment installed in catch processing spaces shall be resistant to sea water and fish processing products influence or shall be adequately protected against it.

19.10.3.2 Electrical equipment distribution gear and start-protection devices specified in 19.10.3.1 shall be installed in special electrical spaces.

19.10.3.3 Cables installed in spaces subjected to prolonged influence of salt and other products of fish processing shall be provided with sheaths resistant to such influence or be adequately protected.

19.10.4 Composition and capacity of main electrical power source.

19.10.4.1 The composition and capacity of the main source of electrical power shall be determined with regard to the following operating conditions of the vessel:

- .1 running conditions;
- .2 manoeuvring;
- .3 in case of fire, hole in the ship's hull or other conditions affecting the safety of navigation, with the main source of electrical power in operation;
- .4 fishing.

19.10.4.2 The capacity of generators composing the main electrical power source shall be such that if any of them fail, the rest will ensure power supply of electrical equipment necessary under conditions specified in 19.10.4.1 as well as minimal habitable conditions to persons on board.

In well-grounded cases, in vessels of less than 500 gross tonnage the capacity necessary to ensure fishing operations and/or catch processing may be neglected.

19.10.5 Distribution of electrical power.

19.10.5.1 Where the main electrical power source incorporates shaft generators not intended for parallel operation with the independently driven generators, the machinery and systems ensuring propulsion, manoeuvrability and safety of navigation shall be supplied from the busbars of independently driven generators, while the electrical equipment of fishing and processing machinery shall be supplied from the busbars of shaft generators.

19.10.5.2 The electric drives of refrigerating compressors shall be supplied by separate feeders from the busbars of the main switchboard. It is admissible for the electric drives of refrigerating compressors to be fed from a separate switchboard supplied by two feeders connected to different sections of the main switchboard.

19.10.5.3 Where portable tools and movable mechanization facilities not permanently installed, are supplied from a circuit of more than 50 V, a safety isolation device in combination with a separating transformer shall be used for each consumer.

Such device shall interrupt power supply if the hull leakage current exceeds 30 mA.

19.10.6 Lighting.

19.10.6.1 Catch processing spaces and refrigerating machinery rooms shall be illuminated by stationary lighting fixtures, which shall be supplied and arranged in compliance with 6.2.3.

19.10.6.2 Fish storage holds shall be illuminated by stationary lighting fixtures, which shall be supplied in accordance with 6.2.7.

19.10.7 Signalling.

A "Man-in-hold" signal push-button shall be located inside the refrigerated holds at each exit to actuate signal at the wheelhouse or another permanently attended space.

19.10.8 Emergency electrical installations.

19.10.8.1 The emergency source of electrical power shall comply with the requirements of 9.3.

19.10.8.2 In addition to the requirements of 9.3.1.1, the emergency source of electrical power shall supply the emergency lighting for the catch processing spaces and the exits therefrom as well as for the deck areas where the fishing machinery is installed.

19.10.8.3 Where a diesel generator is used as the emergency source of electrical power, an emergency transitional source of electrical power (accumulator battery) shall be provided, the capacity of which shall be sufficient to supply the consumers specified in 9.3.7 and 19.10.8.2 during 30 min.

19.11 SHIPS CARRYING DANGEROUS GOODS

19.11.1 General.

19.11.1.1 The requirements of this Chapter, in addition to the requirements of 7.2, Part VI "Fire Protection", apply to the electrical equipment of ships and cargo spaces intended for the carriage of dangerous goods, in compliance with IEC 60092-506.

19.11.2 Dangerous zones, spaces and areas.

19.11.2.1 Classification of dangerous zones.

Zone 1, in which an explosive gas/air mixture is likely to occur in normal operation.

Zone 2, in which an explosive gas/air mixture is not likely to occur, and if it occurs, it will only exist for a short time.

Typical examples of arrangement of the dangerous zones are given in Table 19.11.2.1.

19.11.2.2 For packaged dangerous goods, Class 1, except of subclass 1.4S, the dangerous zones encompass the following spaces and areas classified as *Zone 1*:

.1 enclosed spaces of cargo compartments/holds as well as open or enclosed ro-ro cargo spaces;

.2 integral storerooms for the ship's stock of explosives.

19.11.2.3 For dangerous goods carried in bulk, Class 4.1, 4.2, 9 and MHB (Materials Hazardous in Bulk) capable of producing explosive dust/air mixtures, the dangerous zones encompass the following spaces and areas classified as *Zone 1*:

.1 enclosed spaces of cargo compartments/holds;

.2 air ducts of ventilation systems for spaces of cargo compartments/holds specified in 19.11.2.3.1.

19.11.2.4 For dangerous goods carried in bulk, Class 4.3, capable of producing explosive gaseous mixture, the dangerous zones encompass the following spaces and areas:

19.11.2.4.1 *Zone 1*:

.1 enclosed spaces of cargo compartments/holds;

.2 air ducts of ventilation systems for spaces of cargo compartments/holds specified in 19.11.2.4.1.1;

.3 areas on open deck or semi-enclosed spaces on open deck within 1,5 m of any ventilation outlets of cargo compartments/holds specified in 19.11.2.4.1.1;

.4 enclosed or semi-enclosed spaces having direct access to or other openings into spaces and areas specified in 19.11.2.4.1.1, 19.11.2.4.1.2, unless appropriate measure are taken to prevent the explosive mixture from penetration into these spaces;

.5 air ducts of ventilation systems, pipelines of bilge systems, etc. where open ends of this piping directly face dangerous *Zone 1*.

19.11.2.4.2 *Zone 2*:

.1 enclosed or semi-enclosed spaces with natural ventilation, having direct access to or other openings

Table 19.11.2.1
Dangerous zones for dangerous goods

Subparagraphs	Typical examples	Comments
19.11.2.2 19.11.2.3.1 19.11.2.4.1.1 19.11.2.5.1.1		—
19.11.2.3.2 19.11.2.4.1.2 19.11.2.5.1.2		—
19.11.2.4.1.4 19.11.2.5.1.4		—
19.11.2.4.2.1 19.11.2.5.2.1		natural ventilation
		space under overpressure, visual and audible alarm in control stations to be actuated when pressure drops
19.11.2.4.2.1 19.11.2.5.2.1 — only for fore room		natural ventilation
19.11.2.4.1.3 19.11.2.5.1.3 19.11.2.4.2.2 19.11.2.5.2.2		
	<ul style="list-style-type: none"> — gastight self-closing door — non-dangerous space — dangerous zone 1 — dangerous zone 2 	

into spaces and areas specified in 19.11.2.4.1.1, 19.11.2.4.1.2 and separated from these spaces by gastight self-closing doors as well as directly within air lock, if any;

.2 areas within 1,5 m of areas and spaces on open deck specified in 19.11.2.4.1.3;

.3 closed spaces (e.g. pipe tunnels, pump rooms with bilges, etc.) with piping specified in 19.11.2.4.1.5 along with their flanges, valves, pumps, etc. except

cases when special methods of pressure buildup approved by the Register are used in those spaces.

19.11.2.5 For packaged dangerous goods, Class 2.1 and also Classes 3, 6.1 and 8 (liquids with $T_{flash} \leq 23 \text{ }^\circ\text{C}$), the dangerous zones encompass the following spaces and areas.

19.11.2.5.1 Zone 1:

.1 enclosed spaces of cargo compartments/holds;
.2 air ducts of ventilation systems for spaces of cargo compartments/holds specified in 19.11.2.5.1.1;

.3 areas on open deck or semi-enclosed spaces on open deck within 1,5 m of any ventilation outlets of cargo compartments/tanks specified in 19.11.2.5.1.1;

.4 enclosed or semi-enclosed spaces having direct access to or other openings into one of the above areas specified in 19.11.2.5.1.1 and 19.11.2.5.1.2, unless appropriate measure are taken to prevent the explosive mixture from penetration into these spaces;

.5 air ducts of ventilation systems, pipelines of bilge systems, etc. where open ends of this piping directly face dangerous Zone 1.

19.11.2.5.2 Zone 2:

.1 enclosed or semi-enclosed spaces with natural ventilation having direct access to or other openings into spaces specified in 19.11.2.5.1.1, 19.11.2.5.1.2 and separated from these spaces by gastight self-closing doors, as well as directly within air lock, if any;

.2 areas within 1,5 m of areas or spaces on open deck specified in 19.11.2.5.1.3;

.3 enclosed spaces (e.g. pipe tunnels, pump rooms with bilges, etc.) containing pipes specified in 19.11.2.5.1.5 along with their flanges, valves, pumps, etc. Except for the cases where forced ventilation with 6-time air change is used in those spaces.

19.11.3 Installation of electrical equipment in dangerous spaces and zones.

19.11.3.1 Electrical equipment installed in spaces and areas where only explosive dust is likely to occur due to bulk cargoes, shall comply with the following minimum requirements, unless otherwise specified (refer to Table 19.11.3.2):

.1 protection level IP55 and the maximum surface temperature of 200 °C or,

.2 certified safe type with temperature class T3 and protection level IP55.

19.11.3.2 Electrical equipment installed in areas where only explosive gas atmosphere is likely to occur shall be of certified safe type and comply with the following minimum requirements, unless otherwise specified (refer to Table 19.11.3.2):

.1 temperature class T3;

.2 sub-group of equipment IIB.

The certified safe-type electrical equipment shall be at least with protection suitable for operation in *Zone 1*.

19.11.3.3 Electrical equipment installed in spaces and areas where only solid bulk cargoes and MHB (Materials Hazardous in Bulk) are carried shall comply with the requirements of 19.11.3.1, 19.11.3.2 and the minimum requirements of Table 19.11.3.2.

19.11.3.4 Electrical equipment installed in spaces and areas where explosive gas atmosphere and dust are likely to occur shall comply with the requirements of 19.11.3.1, 19.11.3.2.

19.11.3.5 Electrical equipment installed in spaces and areas where dangerous goods of Class 1, except for Class 1.4S, are likely to be carried, shall comply with the following requirements:

- .1 protection level IP65;
- .2 the maximum surface temperature — 100 °C.

19.11.3.6 Electrical equipment installed in dangerous zone of category 2 shall be:

- .1 of type suitable for use in adjacent spaces in accordance with 19.11.3.1 to 19.11.3.5; or
- .2 of special design for protection class "n" and appropriate temperature class, sub-group and protection level in accordance with 19.11.3.1 to 19.11.3.5; or
- .3 of such design that does not generate arcs or sparks in service and which surfaces do not reach unacceptable high temperatures under normal conditions.

Where the spaces certified for Zone 2 is protected with redundant mechanical ventilation capable of starting automatically electrical equipment not certified

for Zone 2 may be installed provided its automatically disconnected following loss of ventilation. In addition to the above, the manned stations shall be provided with audible and visual alarms activated at the failure in the ventilation system.

For primary essential services such as bilge and ballast ones, the electrical equipment shall be with the certified safe-type electrical equipment with protection suitable for operation in dangerous Zone of category 2.

19.11.3.7 Portable electrical equipment shall, in general, have its own independent source of electrical power (except for intrinsically safe electric circuits) and be of certified safe type with protection suitable for operation in Zone 1.

Where in the spaces belonging to dangerous Zone of category 2 of the reserved forced ventilation system of with automatic switching on, the installation of non-certified for this category electrical equipment provided its automatic switching off and interlocking of switching on during failure of ventilation. In addition to the above, the manned stations shall be provided with audible and visual alarms activated at the failure in the ventilation system.

For primary essential services such as bilge and ballast ones, the electrical equipment shall be with the certified safe-type electrical equipment with protection suitable for operation in dangerous Zone of category 2.

Table 19.11.3.2

Requirements for electrical equipment depending on specific solid bulk cargoes

Dangerous goods	IMO class	Dominant risk ¹	Protection against explosive dust	Protection against explosive gas atmosphere	
				Subgroup A	Temperature class
Aluminium dross	4.3	Hydrogen	—	IIC	T2
Aluminium ferrocilicon powder	4.3	Hydrogen	—	IIC	T2
Aluminium cilicon powder, uncoated	4.3	Hydrogen	—	IIC	T2
Ammonium nitrate fertilizers:		Refer to footnote ²			
type A	5.1		—	—	—
type B	9		—	—	—
Coal	MHB	Dust, methane	IP55	IIA	T4
Direct-reduced iron	MHB	Hydrogen	—	IIC	T2
Ferrophosphorus (no briquettes)	MHB	Hydrogen	—	IIC	T1
Ferrocilicon	4.3	Hydrogen	—	IIC	T1
Iron oxide, spent. Sponge iron, spent	4.2	Dust	IP55	IIA	T2
Seed cake, expelled	4.2	Hexane	—	IIA	T3
Silicomanganese	MHB	Hydrogen	—	IIC	T1
Sulfur	4.1	Inherent	IP55	—	T4
Zinc slag	4.3	Hydrogen	—	IIC	T2

¹ This column relates to the possible evolution of substances, which may affect the installations of electrical equipment and cables.

² Provision shall be made to disconnect all electric circuits terminating within cargo spaces in accordance with the provisions of 2.9.9.

20 REQUIREMENTS FOR ELECTRICAL EQUIPMENT OF REFRIGERATING PLANTS

20.1 GENERAL

20.1.1 The requirements of the Section cover the electrical equipment of classed refrigerating plants.

The requirements of 20.2.3, 20.2.4, 20.3.1 and 20.4 apply to unclassified refrigerating plants as well.

20.2 POWER SUPPLY AND SWITCHING

20.2.1 The electric drives of refrigerating plants shall be powered through separate feeders from the switchboard of the refrigerating plant.

The electric drives of refrigerating compressors may be supplied directly from the main switchboard. The refrigerating fans may be supplied from the switchboard of the refrigerating plant or other switchboard energized directly from the main switchboard.

For each method of power supply it is necessary to provide that in case of generator overload the refrigerating plant electric drives are disconnected in the last turn.

The emergency ventilation system shall be supplied through a separate feeder from the switchboard energized from the main switchboard or directly from the main switchboard.

20.2.2 Power supply of electric drives of thermal containers shall comply with the requirements of 19.5.2.

20.2.3 When using the refrigerants of Group II according to Table 2.2.1, Part XII "Refrigerating Plants", a device shall be provided for emergency remote disconnection of the refrigerating plant switchboard operated from the following locations:

.1 from the permanent control post of the refrigerating plant in the refrigerating machinery room;

.2 from a location outside the space that may be contaminated with the refrigerant of Group II in case of breakdown in the refrigerating machinery room;

.3 outside, near every exit from the refrigerating machinery room.

The apparatus for emergency remote disconnection shall be installed in such a manner that it cannot be actuated inadvertently.

20.2.4 The apparatus for emergency remote disconnection of the switchboard of the refrigerating plant working with Group II refrigerant shall simultaneously switch off the electric drives of refrigerating compressors if they are fed from the main switchboard (refer to 20.2.1), main lighting of the refrigerating machinery compartment and switch on the emergency ventilation, water screens and reserve lighting.

Additionally, near the device for emergency remote disconnection of the refrigerating plant switchboard at locations stated in 20.2.3.1 and 20.2.3.2, devices shall be installed for remote starting in any sequence of emergency ventilation, water screens, and reserve lighting, without disconnection of the refrigerating plant switchboard.

20.2.5 It is recommended that the electrical heating appliances for hatches and doors to refrigerated spaces and freezing chambers shall be supplied at safety voltage.

20.3 VENTILATION

20.3.1 If the refrigerant of Group II is used, the exhaust fan electric motors of the emergency ventilation in the refrigerating machinery rooms, installed in the exhaust ducts, shall be of safe type.

20.3.2 The electric motors of fans located in the stream of air coming from the refrigerated cargo spaces shall have a degree of protection not below IP55.

20.4 LIGHTING

20.4.1 If the refrigerant of Group II is used, safe-type reserve lighting fixtures shall be installed in the refrigerating machinery room in addition to the main lighting fixtures. The reserve lighting fixtures shall be powered separately from the electrical equipment and main lighting fixtures installed in the refrigerating machinery room.

21 SPARE PARTS

21.1 Every ship shall be provided with spare parts in the amount sufficient for repairing when essential services fail at any situation, an accident at sea inclusive, in order to ensure movement, control and safety of a ship and people on board.

21.2 Specifying a required minimum of spare parts, the recommendations of manufacturers of specific kinds of equipment shall be followed.

22 SPECIAL REQUIREMENTS TO ELECTRICAL EQUIPMENT OF SHIP'S ELECTRIC POWER SYSTEM WITH ELECTRICAL POWER DISTRIBUTION FOR DIRECT CURRENT

22.1 GENERAL

22.1.1 These requirements shall apply to the ship electric power d.c. distribution systems with voltage up to 1500 V measured between the pole terminals.

22.1.2 For the ship electric power DC distribution system the use of auxiliary sources and items of alternative three-phase current complying with the applicable sections of this Part of the Rules is permitted.

22.1.3 Both direct current generator and rectifier supplied from the alternating current generator may be the sources of d.c. electrical energy.

22.1.4 In addition to the system for insulation resistance monitoring specified in 2.11, the portable devices for search of insulation fault location shall be applied.

22.2 CONNECTION SYSTEMS OF ELECTRIC POWER SUPPLY UNITS

22.2.1 In addition to the requirement to subdivide the DC main busbar into two parts, specified in 3.5.6, it is allowed to use two independent main switchboards interconnected by cable jumpers or bus cables. Automatic switches shall be provided on both ends of the cable jumper or bus cable. In this case, connection of generators and duplicated consumers shall be symmetrically distributed between the main switchboards, where practicable.

22.3 ELECTRICAL POWER DISTRIBUTION

22.3.1 Distribution systems and permissible voltage.

22.3.1.1 In the ship electric power d.c. distribution systems and the unified electric power d.c. distribution plants only the application of two-wire insulated system of electrical energy distribution is allowed.

22.3.1.2 The permissible d.c. voltage at the terminals of electric power sources shall not exceed 1500 V.

22.3.1.3 At least two voltmeters shall be provided for d.c. main switchboard. In case d.c. main switchboards are divided, each part shall be fitted with a voltmeter.

22.3.1.4 One ammeter and one voltmeter shall be provided for each rectifier supplying d.c. busbars.

22.3.2 Power supply of essential consumers.

22.3.2.1 Essential consumers may be supplied from the d.c. power distribution box via the converter or from the separate a.c. distribution box supplied from the a.c. generators complying with the requirements of 3.1 and 3.2.

22.3.3 Distribution box arrangement.

22.3.2.2 D.c. main switchboard, generator sets and rectifiers shall be located in close vicinity to each other, as stated in 4.6.6.5.

22.4 PROTECTION DEVICES

22.4.1 Faults on the DC generator side.

22.4.1.1 When the protection specified in 8.2.6 is activated, the generator shall be shut off from the main switchboard and its excitation shall automatically be removed.

22.4.2 Faults on the rectifier side.

22.4.2.1 The rectifiers shall be fitted with protection devices against the pole-to-pole fault in the cable or bus cable connecting the rectifier and the main switchboard.

22.4.2.2 Residual current devices shall be applied to control earthing of the poles in equipment and feeders of direct current system,

22.4.2.3 An audible and visual alarm shall be activated in the system at any earth faults.

22.5 ELECTRICAL MACHINES

22.5.1 D.c. generators and electric motors of nominal rated power 1000 kW and above shall be fitted with differential protection devices. For this purpose, a separate lead box shall be provided on a motor casing, located on the opposite side from the main box the slots for the sensors of differential protection shall be provided.

22.5.2 A.c. generators and built-in rectifiers may be provided with common cooling system.

22.6 AC POWER SUPPLY CONSUMER TRANSFORMERS

22.6.1 Transformers fed from the converters and used as power source shall comply with the rate parameter of permissible stress rate while feeding from the pulse sources.

22.7 ELECTRICAL POWER CONVERTERS

22.7.1 Heat transfer from power semiconductor elements of converters for d.c. distribution may be performed both by the air cooling system and liquid air coolers.

22.7.2 The rectifiers intended for the parallel operation shall be capable of equal load distribution including short-term load.

22.7.3 The voltage at the uncontrolled rectifier output may be maintained by the excitation system of

the generator to be used as power source for the rectifier.

22.7.4 The rectifiers of d.c. power sources shall contain a device for overshoot suppression and reception of excess energy at the rectifier outlet connected to d.c. distribution device.

22.7.5 As the rectifiers of d.c. electrical power source, the active controlled rectifiers constructed by the power source principle with the possibility to stabilize the output voltage and the additional function of reactive power compensation at the input may be applied.

22.7.6 In d.c. input circuit the inverters of the main propulsion plant shall be fitted with a device for overvoltage limitation and reception of surplus power from the electric drive in the regeneration mode.

22.7.7 In the output circuits of inverters the filters shall be installed to limit the stress rate up to the permissible level and to protect the coil insulation of the electric machine or transformer connected to the inverter.

LIST OF CIRCULAR LETTERS AMENDING/SUPPLEMENTING NORMATIVE DOCUMENT

(Normative document No. and title)

Item No.	Circular letter No., date of approval	List of amended and introduced paras /chapters/ sections



RUSSIAN MARITIME REGISTER OF SHIPPING

CIRCULAR LETTER

No. 315-06-1063c

dated 27.11.2017

Re:

amendments to Part XI "Electrical Equipment" of the Rules for the Classification and Construction of Sea-Going Ships, 2017, ND No. 2-020101-095-E

Item of technical supervision:
construction of ships

Implementation: from the date of publication

Valid: till -

Validity period extended till -

Cancels / amends / supplements Circular letter No. - dated -

Number of pages: 1

Appendices: -

Director General

K.G. Palnikov

Amends Rules for the Classification and Construction of Sea-Going Ships, 2017, ND No. 2-020101-095-E

Para 7.5.11.4 in Part XI "Electrical Equipment" of the Rules for the Classification and Construction of Sea-Going Ships, 2017, ND No. 2-020101-095-E shall be deleted.
The existing para 7.5.11.5 shall be renumbered 7.5.11.4.

It is necessary to do the following:

1. Familiarize the surveyors of the RS Branch Offices with the content of the Circular Letter.
2. Bring the content of the Circular Letter to the notice of the interested organizations in the area of the RS Branch Offices' activity.
3. Apply the provisions of the Circular Letter.

Person in charge: A.V. Vinogradov

Department 315

+7 (812) 605-05-17

"Thesis" System: No. 17-292704



RUSSIAN MARITIME REGISTER OF SHIPPING

CIRCULAR LETTER

No. 315-28-1065c

dated 04.12.2017

Re:

amendments to Section 16 of Part XI "Electrical Equipment" of the Rules for the Classification and Construction of Sea-Going Ships, 2018, ND No. 2-020101-104-E

Item of technical supervision:

high-frequency data transfer cables

Implementation: 01.01.2018

Valid: till 31.12.2018

Validity period extended till ---

Cancels / amends / supplements Circular Letter No. --- dated ---

Number of pages: 1 + 1

Appendices: text of amendments to Section 16, Part XI "Electrical Equipment" of the Rules for the Classification and Construction of Sea-Going Ships, 2018, ND No. 2-020101-104-E

Director General

K.G. Palnikov

Amends Rules for the Classification and Construction of Sea-Going Ships, 2018, ND No. 2-020101-104-E

We hereby inform that in Section 16, Part XI "Electrical Equipment" of the Rules for the Classification and Construction of Sea-Going Ships, 2018, ND No. 2-020101-104-E new requirements regarding high-frequency data transfer cables shall be introduced as specified in the Appendix to the Circular Letter. The requirements will be introduced into the Rules for the Classification and Construction of Sea-Going Ships, 2019.

It is necessary to do the following:

- 1) Familiarize the RS surveyors and interested organizations in the area of the RS Branch Offices' activity with the content of the Circular Letter.
- 2) Apply provisions of the Circular Letter;
- 3) Clarify the contents of the Circular Letter to all interested parties in the area of the RS Branch Offices' activity.

Person in charge: M.D. Vasilioglo

Dept. 315

+7 812 605 05 17

"Thesis" System: 17-268603

**RULES FOR THE CLASSIFICATION AND CONSTRUCTION OF SEA-GOING SHIPS,
2018, ND No. 2-020101-104-E**

PART XI. ELECTRICAL EQUIPMENT

16 CABLES AND WIRES

Para 16.8.1.2 shall be supplemented with the following text:

“In data transfer circuits high-frequency cables may be used with the core diameter of 0,4 – 0,8 mm considering mechanical strength of such cables in compliance with IEC 60092-370.”.

Para 16.8.4.17 shall be supplemented with the following text:

“Minimum internal bending radii of high-frequency data transfer cables shall be at least 8 external diameters for unscreened and 10 external diameters for screened cables.”.



RUSSIAN MARITIME REGISTER OF SHIPPING

CIRCULAR LETTER

No. 315-08-1118c

dated **04.04.2018**

Re:

amendments to the Rules for the Classification and Construction of Sea-Going Ships, 2018,
ND No. 2-020101-104-E

Item(s) of technical supervision:

main machinery and electric propulsion plant control systems

Implementation:

from the date of publication

Valid till:

--

Validity extended till:

--

-

Cancels / amends/ supplements Circular Letter No. ---

dated --

Number of pages:

1+1

Appendix(-ces):

text of amendments to Parts XI "Electrical Equipment" and XV "Automation"

Director General

K.G. Palnikov

Text of CL:

We hereby inform that the Rules for the Classification and Construction of Sea-Going Ships shall be amended as specified in the Appendix to the Circular Letter.

The above amendments will be introduced into the Rules at their re-publication.

It is necessary to do the following:

1. Familiarize the surveyors of the RS Branch Offices with the content of the Circular Letter.
2. Bring the content of the Circular Letter to the notice of the interested organizations in the area of the RS Branch Offices' activity.
3. Apply the provisions of the Circular Letter.

List of ND amended and introduced paras/chapters/sections (to specify in the List of Circular Letters (form 8.3.36)):

Part XI: para 17.14.6

Part XV: para 3.1.2

Person in
charge:

Andrey V. Vinogradov

Department 315

+7 (812) 605-05-17

"Thesis" System No.

18-67392

**RULES FOR THE CLASSIFICATION AND CONSTRUCTION OF SEA-GOING SHIPS,
2018,**

ND No. 2-020101-104-E

PART XI. ELECTRICAL EQUIPMENT

17 ELECTRIC PROPULSION PLANTS

New para 17.14.6 shall be introduced reading as follows:

"17.14.6 Power supply of electric propulsion plant control systems.

17.14.6.1 Power supply of the remote control system of electric propulsion plant shall be carried out in accordance with 3.1.2, Part XV "Automation".

17.14.6.2 Arrangements (units) of control or controllers of each electric propulsion motor or semiconductor frequency converter shall be supplied by separate circuits. Malfunction in the supply circuit of one of such control units shall not cause loss of power supply to the remaining operative units."

PART XV. AUTOMATION

3 POWER SUPPLY OF AUTOMATION SYSTEMS

Para 3.1.2 shall be amended to read:

"3.1.2 The control systems of main machinery shall be supplied by two separate feeders from separate sections of the main switchboard or from switchboards intended for the power supply of essential services and connected to the separate sections of the main switchboard. If main switchboard busbars are not divided into sections, one of the feeders may be connected to the main switchboard and the other may be connected to the supply switchboard of essential services or to the nearest distribution board. The changeover from one feeder to another shall be effected automatically with appropriate signal activated at the control station."

Российский морской регистр судоходства
Правила классификации и постройки морских судов
Часть XI
Электрическое оборудование

Russian Maritime Register of Shipping
Rules for the Classification and Construction of Sea-Going Ships
Part XI
Electrical Equipment

The edition is prepared
by Russian Maritime Register of Shipping
8, Dvortsovaya Naberezhnaya,
191186, St. Petersburg,
Russian Federation
www.rs-class.org/en/