

**RUSSIAN MARITIME REGISTER OF SHIPPING**

---

**RULES**  
**FOR THE CLASSIFICATION**  
**AND CONSTRUCTION**  
**OF SEA-GOING SHIPS**

**PART VII**  
**MACHINERY INSTALLATIONS**



Saint-Petersburg  
Edition 2018

Rules for the Classification and Construction of Sea-Going Ships of Russian Maritime Register of Shipping have been approved in accordance with the established approval procedure and come into force on 1 January 2018.

The present twentieth edition of the Rules is based on the 2017 edition taking into account the amendments developed immediately before publication.

The unified requirements, interpretations and recommendations of the International Association of Classification Societies (IACS) and the relevant resolutions of the International Maritime Organization (IMO) have been taken into consideration.

The Rules are published in the following parts:

Part I "Classification";

Part II "Hull";

Part III "Equipment, Arrangements and Outfit";

Part IV "Stability";

Part V "Subdivision";

Part VI "Fire Protection";

Part VII "Machinery Installations";

Part VIII "Systems and Piping";

Part IX "Machinery";

Part X "Boilers, Heat Exchangers and Pressure Vessels";

Part XI "Electrical Equipment";

Part XII "Refrigerating Plants";

Part XIII "Materials";

Part XIV "Welding";

Part XV "Automation";

Part XVI "Hull Structure and Strength of Glass-Reinforced Plastic Ships and Boats";

Part XVII "Distinguishing Marks and Descriptive Notations in the Class Notation Specifying Structural and Operational Particulars of Ships";

Part XVIII "Common Structural Rules for Bulk Carriers and Oil Tankers". The text of the Part is identical to that of the IACS Common Structural Rules;

Part XIX "Additional Requirements for Structures of Container Ships and Ships, Dedicated Primarily to Carry their Load in Containers". The text of the Part is identical to IACS UR S11A "Longitudinal Strength Standard for Container Ships" (June 2015) and S34 "Functional Requirements on Load Cases for Strength Assessment of Container Ships by Finite Element Analysis" (May 2015).

Parts I to XVII are published in electronic format and hard copy in Russian and English. In case of discrepancies between the Russian and English versions, the Russian version shall prevail.

Parts XVIII to XIX are published in English and in electronic format only.

*As compared to the 2017 edition, the present edition of the Rules contains the following amendments.*

## **RULES FOR THE CLASSIFICATION AND CONSTRUCTION OF SEA-GOING SHIPS**

### **PART VII. MACHINERY INSTALLATIONS**

1. Paras: 1.1.2, 2.1.1.5, 2.1.11, 2.2.1, 2.3.1, 2.4.3, 4.4.7, 5.3.1, 5.3.2, 5.4.2, 6.1.2, 7.1.2, 7.1.5, 7.2.15, 8.4.2, 8.8.5, 9.1.6;

Note 3 to Table 1.3.2.3;

Footnote "1" to Table 5.2.5 and Footnote "1" to Table 5.4.3-2: the requirements have been specified to avoid the ambiguous phrase "special consideration" etc.

2. Chapter 1.1: in para 1.1.1 the applied requirements to the ships of gross tonnage less than 500 and berth-connected ships have specified.

3. Chapter 1.2: in para 1.2.1 the new definitions "Shafting", "Steering System" have been introduced; the definition "Machinery Spaces of Category A" has been specified in compliance II-2/3.31.3 SOLAS-74 Convention.

4. Chapter 1.3: in Table 1.3.2.3 the requirements to the applied materials of the AMSS components and parts have been specified.

5. Chapter 4.2: in para 4.2.3 the requirements to the furnaces of the auxiliary boilers furnace have ben specified.

6. Chapter 4.5: in para 4.5.13.3 the requirements to the escape routes from steering gear spaces in compliance with IACS UR SC269 (Rev.1 Dec 2016), para 3, have been specified.

7. Chapter 6.2: in explication to Formulas 6.2.1-2 and 6.2.1-3 the definition of the relative radius of design section has been specified.

8. Chapter 7.2: paras 7.2.3, 7.2.5, 7.2.7 and 7.2.14 have been made in compliance with IACS UR SC242 (Rev.1 Apr 2016);

para 7.2.10 ahs been supplemented with the reference to para 17.3.4, Part XI "Electrical Equipment" in relation to the breaking or locking devices for a propulsion shaft.

9. Editorial amendments have been made.

# CONTENTS

## PART VII. MACHINERY INSTALLATIONS

<b>1</b>	<b>General</b> . . . . .	7	<b>8</b>	<b>Torsional vibration.</b> . . . . .	34
1.1	Application . . . . .	7	8.1	General . . . . .	34
1.2	Definitions and explanations . . . . .	7	8.2	Permissible stresses for crankshafts . . . . .	34
1.3	Scope of surveys . . . . .	9	8.3	Permissible stresses for intermediate, thrust, propeller shafts and generator shafts . . . . .	35
<b>2</b>	<b>General requirements</b> . . . . .	10	8.4	Permissible torque in reduction gear . . . . .	36
2.1	Power of main machinery . . . . .	10	8.5	Permissible torque and temperature of flexible couplings . . . . .	36
2.2	Number of main boilers . . . . .	12	8.6	Other installation components . . . . .	36
2.3	Environmental conditions . . . . .	12	8.7	Torsional vibration measurement . . . . .	36
2.4	Materials and welding . . . . .	13	8.8	Restricted speed ranges . . . . .	36
2.5	Indicating instruments . . . . .	13	<b>9</b>	<b>Vibration of machinery and equipment.</b>	
2.6	Application of the reliability measures of the machinery installations . . . . .	13		<b>Vibration standards</b> . . . . .	38
<b>3</b>	<b>Control devices and stations. Means of communication</b> . . . . .	14	9.1	General . . . . .	38
3.1	Control devices . . . . .	14	9.2	Standardized vibration parameters . . . . .	38
3.2	Control stations . . . . .	14	9.3	Vibration standards for internal combustion engines . . . . .	39
3.3	Means of communication . . . . .	16	9.4	Vibration standards for main geared turbines and thrust bearings . . . . .	39
<b>4</b>	<b>Machinery spaces, arrangement of machinery and equipment</b> . . . . .	17	9.5	Vibration standards for auxiliary machinery of rotary type . . . . .	41
4.1	General . . . . .	17	9.6	Vibration standards for piston air compressors . . . . .	47
4.2	Arrangement of machinery and equipment . . . . .	17	9.7	Vibration standards for boilers and heat exchangers . . . . .	47
4.3	Arrangement of fuel oil tanks . . . . .	17	9.8	Vibration standards for geared gas turbines . . . . .	47
4.4	Installation of machinery and equipment . . . . .	18	9.9	Vibration standards for power-driven azimuth thrusters . . . . .	47
4.5	Means of escape from machinery spaces . . . . .	18	<b>10</b>	<b>Machinery technical condition monitoring systems</b> . . . . .	51
4.6	Insulation of heated surfaces . . . . .	21	10.1	General . . . . .	51
<b>5</b>	<b>Shafting</b> . . . . .	22	10.2	Control items and parameters . . . . .	51
5.1	General . . . . .	22	10.3	General requirements for technical condition monitoring systems . . . . .	51
5.2	Construction and diameters of shafts . . . . .	22	10.4	Technical documentation . . . . .	52
5.3	Shaft couplings . . . . .	24	10.5	Requirements for working lubricating oil parameters . . . . .	52
5.4	Keyless fitting of propellers and shaft couplings . . . . .	24	10.6	Requirements for control of the diesel engine working process parameters . . . . .	52
5.5	Arrangement of shafting supports . . . . .	26	10.7	Requirements for control of wear parameters of the engine cylinder and piston assembly . . . . .	53
5.6	Shaft bearings . . . . .	26	10.8	Requirements for control of vibration parameters . . . . .	53
5.7	Stern-tube sealing arrangements . . . . .	27	10.9	Requirements for control of the shock pulse . . . . .	54
5.8	Braking devices . . . . .	27	10.10	Requirements for the trend analysis of the diagnostic parameters and for the technical condition prediction . . . . .	54
5.9	Hydraulic tests . . . . .	27			
<b>6</b>	<b>Propellers</b> . . . . .	28			
6.1	General . . . . .	28			
6.2	Blade thickness . . . . .	28			
6.3	Propeller boss and blade fastening parts . . . . .	29			
6.4	Propeller balancing . . . . .	30			
6.5	Controllable pitch propellers . . . . .	30			
6.6	Hydraulic tests . . . . .	30			
<b>7</b>	<b>Active means of the ship's steering</b> . . . . .	31			
7.1	General . . . . .	31			
7.2	Construction requirements . . . . .	31			
7.3	Alarms . . . . .	33			
7.4	Hydraulic tests . . . . .	33			

---

<b>11 Qualitative failure analysis for propulsion and steering on passenger ships . . . . .</b>	<b>55</b>	11.4 Verification of solutions. . . . .	55
11.1 Scope of application. . . . .	55	Appendix 1. List of minimum. Recommended spare parts . . . . .	57
11.2 Systems to be considered . . . . .	55	Appendix 2. Special approval of alloy steel for intermediate shaft material. . . . .	60
11.3 Failure criteria . . . . .	55		



# PART VII. MACHINERY INSTALLATIONS

## 1 GENERAL

### 1.1 APPLICATION

**1.1.1** The requirements of the present Part of the Rules apply to ship machinery installations, equipment of machinery spaces, shafting lines, propellers, machinery condition monitoring systems, spare parts and active means of the ship's steering (refer to 7.1.1).

In this case, requirements of Sections 1 to 4 and 9 and recommendations of Appendix 1 of the machinery installations and machinery space equipment on ships of gross tonnage less than 500, as well as the requirements of Part IX "Machinery" may be applied in so much as applicable and sufficient. It also refers to berth-connected ships.

The requirements for machinery installations of polar class ships (refer to 2.2.3.1, Part I "Classification") are set forth in Section 1, Part XVII "Distinguishing Marks and Descriptive Notations in the Class Notation Specifying Structural and Operational Particulars of Ships".

The requirements to machinery installations of Baltic ice class ships (refer to 2.2.3.1, Part I "Classification") are specified in Section 10, Part XVII "Distinguishing Marks and Descriptive Notations in the Class Notation Specifying Structural and Operational Particulars of Ships".

*Note.* List of minimum recommended spare parts is specified in Appendix 1 to this Part.

**1.1.2** The requirements of the present Part are set forth proceeding from the condition that the flash point of fuel oil (refer to 1.2, Part VI "Fire Protection") used in ships of unrestricted service for the engines and boilers is not below 60 °C and the flash point of fuel for emergency generator engines, not below 43 °C.

In ships certified for restricted service within areas having a climate ensuring that ambient temperature of spaces where such fuel oil is stored will not rise to within 10 °C below its flash point may use fuel oil with flash point not less than 43 °C. In this case, measures shall be taken to ensure checking and maintenance of the above condition.

The use of fuel having a flash point of less than 43 °C may be permitted for cargo ships only subject to the technical substantiation submitted to the Register.

Such fuel shall not be stored in any machinery space.

Crude oil and slops may be used as boiler fuel in oil tankers. The conditions of such use are stated under 13.11, Part VIII "Systems and Piping".

On gas carriers for gas turbine engines and dual-fuel internal combustion engines it is allowed to use the natural gas (methane) carried as fuel. Conditions

of application of natural gas as fuel are set out in 13.12, Part VIII "Systems and Piping" and in 8.10 and Section 9, Part IX "Machinery".

### 1.2 DEFINITIONS AND EXPLANATIONS

**1.2.1** Definitions and explanations relating to general terminology of the Rules are given in Part I "Classification".

The following definitions, as adopted in the present Part, are equally applicable for the purpose of Part VIII "Systems and Piping" and Part IX "Machinery".

**Shafting** is a structural complex that kinematically connects ship's main machinery or the main gearing (if available) with a propeller including propeller, intermediate and other shafts complete with couplings and also a sterntube arrangement with bearings, seals, lubrication and cooling systems, other arrangements (e.g. the propeller shaft sag measuring gauges, protective covers, braking arrangement, etc.) and involved in transmitting torque from the engine to propeller.

**Auxiliary active means of the ship's steering** is a propulsion and steering unit ensuring propulsion and steering of a ship at low speed or steering of a ship at zero speed when the ship is equipped with main means of propulsion and steering, and is used either in combination with the latter or when the main means of propulsion and steering are inoperative.

**Auxiliary machinery** is the machinery necessary for the operation of main engines, supply of the ship with electric power and other kinds of energy, as well as functioning of the systems and arrangements subject to survey by the Register.

Among the essential auxiliary machinery are:

a generating set, which serves as a main source of electrical power;

steam supply source;

condensate pump and arrangements used for maintaining vacuum in condensers;

the mechanical air supply for boilers;

an air compressor and receiver for starting or control purposes;

as well as machinery ensuring operation or functioning of:

boiler feed water systems;

the fuel oil supply systems for boilers or engines;

the sources of water pressure;

the hydraulic, pneumatic or electrical means for control in main propulsion machinery including controllable pitch propellers.

Exit is an opening in bulkhead or deck provided with closing means and intended for the passage of persons.

Means of escape comprise the escape routes leading from the lowest part of the machinery space floor plates to the exit from that space.

Main active means of the ship's steering is a propulsion and steering unit being part of the propulsion plant.

Main machinery is the machinery being part of the propulsion plant.

Technical condition diagnosis is a process of establishing causes for the deviation of diagnostic parameters when performing condition monitoring and/or detecting malfunctions, as a rule, by stripless methods in order to provide maintenance and repair on the actual condition basis.

Remote control is the changing of the speed and direction of rotation as well as starting and stopping of the machinery from a remote position.

Engine room is a machinery space intended for the main engines and, in the case of ships with electric propulsion plants, the main generators.

Machinery spaces are all machinery spaces of category A and all other spaces containing main machinery, shafting, boilers, fuel oil units, steam and internal combustion engines, generators and other major electrical machinery, fuel oil filling stations, ventilation and air-conditioning installations, refrigerating plants, steering engines, stabilizing equipment and similar spaces, and trunks to such spaces.

Machinery spaces of category A are those spaces and trunks to such spaces, which contain:

internal combustion machinery used for main propulsion; or

internal combustion machinery used for purposes other than main propulsion where such machinery has in the aggregate a total power output of not less than 375 kW; or

any oil-fired boiler or oil fuel unit, or any oil-fired equipment other than boilers, such as inert gas generators, incinerators, etc.

Local control station is a control station fitted with controls, indicators, means of communication (if necessary), located in proximity to, or directly on, the engine.

Torsional vibration stresses are stresses resulting from the alternating torque, which is superimposed on the mean torque.

Dead ship condition (as well as black out) is a condition, under which the main propulsion plant, boilers and auxiliaries are not in operation and in restoring the propulsion, no stored energy for starting the propulsion plant, the main source of electrical power and other essential auxiliaries shall be assumed available. It is assumed

that means are available to start the emergency generator at all times.

Equipment comprises all types of filters, heat exchangers, tanks and other arrangements ensuring normal operation of a machinery installation.

Common control station is a control station intended for simultaneous control of two or several main engines and fitted with indicating instruments, alarm devices and means of communication.

Cargo control room (CCR) is a room or part thereof where the control, monitoring means and alarm devices, related to performance of cargo handling operations are located; and onboard the tankers, in addition, means for monitoring and alarm of cargo, ballast, atmosphere parameters of cargo and ballast tanks and cargo pump rooms as well as discharge of oil containing and flushing water.

Technical condition prediction is a process of determining causes for the changes in control item for the forthcoming time period, based on the trend of the diagnostic parameter values during the preceding time period.

Propulsion plant is the totality of machinery and arrangements intended for generating, converting and transmitting power ensuring propulsion of the ship at all specified rates of speed and comprising propellers, shafting, main gearing and main machinery, including electric propulsion motors.

Rated power means the maximum continuous (not time-limited) power adopted in calculations under the Rules and stated in documents issued by the Register.

Rated speed means the speed corresponding to the rated power.

Steering system is ship's directional control system, including main steering gear, auxiliary steering gear, steering gear control system and rudder if any (refer to 1.2.9, Part III "Equipment, Arrangements and Outfit").

Technical condition monitoring system is a complex of inspection facilities and actuators interacting with the control item on demand set forth by the appropriate documentation. The condition monitoring system provides for the identification of the type of the item technical condition and systematic observation (tracing) of its change on the basis of measurement of the controlled (diagnostic) parameters and comparison of these values with the set standards.

Active means of the ship's steering (AMSS) are special propulsion and steering units and any combinations of them or with the main propulsion devices, capable of producing thrust or traction force both at a fixed angle to the centre plane of the ship and at a variable angle, either under all running conditions (main AMSS) or part thereof including small and zero speed (auxiliary AMSS) (refer

also to 1.2.8, Part III "Equipment, Arrangements and Outfit").

Fuel oil unit is any equipment used for the preparation and delivery of fuel oil (heated or unheated) to boiler, inert gas generator or engine (including gas turbines) and includes any fuel oil pumps, separators, filters and heaters at a pressure of more than 0,18 MPa.

Fuel oil transfer pumps are not considered as fuel oil units.

Main machinery control room is a space containing the remote controls of main and auxiliary machinery, CP-propellers, main and auxiliary AMSS, indicating instruments, alarm devices and means of communication.

Trend in diagnostic parameter (parameter trend) is a time history of the diagnostic parameter shown graphically or in other form (previous history of the parameter change).

### 1.3 SCOPE OF SURVEYS

**1.3.1** General provisions covering the procedure of classification and surveys during construction and in service are stated in the General Regulations for the Classification and Other Activity and in Part I "Classification".

**1.3.2** Survey by the Register, including the approval of technical documentation according to 3.2.8, Part I "Classification", shall cover the following parts and components:

**.1** shafting as assembled, including propeller shaft with liners and waterproof coatings, shaft bearings, thrust blocks and sterntube bearings, couplings, sterntube seals;

**.2** propellers, inclusive vertical-axis propellers and jets, steerable propellers, athwartship thrusters and propulsive systems of active rudders, pitch control units, oil distribution boxes and control systems of propellers;

**.3** parts indicated in Table 1.3.2.3 and the corresponding spare parts specified in 10.2.

**1.3.3** Subject to survey by the Register is the assembling of the machinery space equipment and testing of the following components of the machinery installation:

**.1** main engines with reduction gears and couplings;

**.2** boilers, heat exchangers and pressure vessels;

**.3** auxiliary machinery;

**.4** control, monitoring and alarm systems of the machinery installation;

**.5** shafting and propellers;

**.6** active means of the ship's steering.

**1.3.4** After assembling of machinery, equipment, systems and piping arrangements on board the ship, the machinery installation shall be tested in operation under load according to the program approved by the Register.

Table 1.3.2.3

Parts to be supervised			
Nos	Item	Material	Chapter of Part XIII "Materials"
<b>1</b>	<b>Shafting</b>		
<b>1.1</b>	Intermediate, thrust and propeller shafts	Forged steel	3.7
<b>1.2</b>	Propeller shaft liners	Copper alloy Corrosion-resistant steel	4.1
<b>1.3</b>	Half-couplings	Forged steel Cast steel	3.7 3.8
<b>1.4</b>	Coupling bolts	Forged steel	3.7
<b>1.5</b>	Sterntubes	Rolled steel Cast steel Forged steel Cast iron	3.2 3.8 3.7 3.9
<b>1.6</b>	Sterntube and strut bushes	Cast steel Copper alloy Forged steel Cast iron	3.8 4.2 3.7 3.9 3.10
<b>1.7</b>	Lining of sternbush bearing	Non-metallic materials Metal alloys	On agreement with the Register
<b>1.8</b>	Thrust block casing	Rolled steel Cast steel Cast iron	3.2 3.8 3.9
<b>2</b>	<b>Propellers</b>		
<b>2.1</b>	Solid propellers	Cast steel Copper alloy	3.12 4.2
<b>2.2</b>	Built propellers		
<b>2.2.1</b>	Blades	Cast steel Copper alloy	3.12 4.2
<b>2.2.2</b>	Boss	Cast steel Copper alloy	3.12 4.2
<b>2.2.3</b>	Bolts (studs) for securing of blades, hub cones and seals	Copper alloy Forged steel	4.1 3.7
<b>2.3</b>	Hub cones	Cast steel Copper alloy	3.12 4.1 4.2
<b>2.4</b>	CPP sliding shoes in Arc4 to Arc9 ice class ships and icebreakers	Forged steel Cast steel	3.7 3.8
<b>2.5</b>	Casings of main AMSS in Arc4 to Arc9 ice class ships and icebreakers	Forged Steel Cast Steel Rolled Steel	3.7 3.8 3.2
<p>Notes: 1. The materials shall be selected in accordance with 2.4. 2. All shafts (propeller, thrust, intermediate), propeller blades shall be subjected to non-destructive testing when manufactured. The methods, standards and scope of such tests shall be agreed with the Register. 3. The nomenclature and material of the CPP components: crank pin rings, sliding shoes (other than those given under item 2.4), push-pull rods; hydraulic cylinders, etc., as well as the AMSS parts (other than those given under item 2.5) shall be agreed with the Register.</p>			

## 2 GENERAL REQUIREMENTS

### 2.1 POWER OF MAIN MACHINERY

**2.1.1** The requirements to power at the propeller shafts of icebreakers and ice class ships are specified in 2.1.1.1 to 2.1.1.4 depending on their ice class.

**2.1.1.1** The power at icebreaker propeller shafts shall be substantiated and correspond to their ice class in compliance with 2.2.3, Part I "Classification".

**2.1.1.2** The minimum required power delivered to the propeller shaft of ships of ice classes **Ice2** and **Ice3** shall not be less than any of the values determined according to 2.1.1.3 and 2.1.1.4.

The minimum required power delivered to the propeller shaft of ice ships of arctic category **Arc4** shall not be less than the lesser of values determined according to 2.1.1.3 and 2.1.1.4.

The minimum required power delivered to the propeller shaft of ships of ice classes **Arc5** to **Arc9** shall be determined according to 2.1.1.3.

**2.1.1.3** Power  $P_{min}$ , in kW, shall be determined by the formula

$$P_{min} = f_1 f_2 f_3 (f_4 \Delta + P_0) \quad (2.1.1.3)$$

where  $f_1 = 1,0$  for fixed pitch propellers;  
 $f_1 = 0,9$  for propulsion plants with controllable pitch propellers or electric drive;  
 $f_2 = \varphi/200 + 0,675$  but not more than 1,1;  
 $\varphi$  = slope of stem (refer to 3.10.1.2, Part II "Hull");  
 $f_2 = 1,1$  for a bulbous stem;  
the product  $f_1 f_2$  shall be taken in all cases not less than 0,85;  
 $f_3 = 1,2 B/\sqrt{\Delta}$  but not less than 1,0;  
 $B$  = breadth of the ship, m;  
 $\Delta$  = ship's displacement to the summer load waterline (refer to 1.2.1, Part III "Equipment, Arrangements and Outfit"), t.  
When calculating for ships of ice classes **Ice2** and **Ice3**  $\Delta$  need not be taken more than 80000 t;  
 $f_4$  and  $P_0$  are given in Table 2.1.1.3.

Irrespective of the results obtained in calculating the power as per Formula (2.1.1.3), the minimum power, in kW, shall not be less than:

10000 kW for **Arc9** ice class ships;

7200 kW for **Arc8** ice class ships;

5000 kW for **Arc7** ice class ships;

3500 kW for **Arc6** ice class ships;

2600 kW for **Arc5** ice class ships;

1000 kW for **Arc4** ice class ships;

740 kW for ships of ice classes **Ice2** and **Ice3**.

**2.1.1.4** The power  $P_{min}$ , in kW, shall be determined as the maximum value calculated for the upper (UIWL) and lower ice waterlines (LIWL) as indicated in 1.1.3, Part XVII "Distinguishing Marks and Descriptive Notations in the Class Notation Specifying Structural and Operational Particulars of Ships" as per the formula

$$P_{min} = K_e \frac{(R_{CH}/1000)^{3/2}}{D_p} \quad (2.1.1.4-1)$$

where  $K_e$  = coefficient given in Table 2.1.1.4-1;

$R_{CH}$  = parameter determined as per the formula

$$R_{CH} = 845 C_{\mu} (H_F + H_m)^2 (B + C_{\psi} H_F) + 42 L_{PAR} H_F^2 + 825 (LT/B^2)^3 \frac{A_{wf}}{L} \quad (2.1.1.4-2)$$

where  $C_{\mu} = 0,15 \cos \varphi_2 + \sin \psi / \sin \alpha$ , but not less than 0,45;

$H_F = 0,26 + (H_M B)^{0,5}$ ;

$H_M = 1,0$  for **Arc4** ice class ships;

$H_M = 0,8$  for ships of ice class **Ice3**;

$H_M = 0,6$  for ships of ice class **Ice2**;

$B$  = breadth of the ship, m;

$C_{\psi} = 0,047 \psi - 2,115$ ,  $C_{\psi} = 0$  at  $\psi < 45^\circ$ ;

$L_{PAR}$  = length of the parallel midship body, m;

$L$  = length of the ship between the perpendiculars, m;

$T$  = draught at UIWL or LIWL, m;

$A_{wf}$  = area of the waterline of the bow, m<sup>2</sup>;

$\alpha$  = angle of the waterline at  $B/4$ , degree;

$\varphi_1$  = rake of the stem at the centreline, degree;

$\varphi_1 = 90^\circ$  for a ship with a bulbous bow;

$\varphi_2$  = rake of the bow at  $B/4$ , degree;

$\psi = \arctan(\tan \varphi_2 / \sin \alpha)$ ;

$D_p$  = diameter of the propeller, m;

$L_{BOW}$  = length of the bow, m.

The value  $(LT/B^2)^3$  shall be taken within the range  $5 < (LT/B^2)^3 < 20$ .

Formula (2.1.1.4-1) may be used when the conditions given in Table 2.1.1.4-2 are fulfilled.

Table 2.1.1.3

Displacement $\Delta$ , t	Value	Ice class ships							
		<b>Ice2</b>	<b>Ice3</b>	<b>Arc4</b>	<b>Arc5</b>	<b>Arc6</b>	<b>Arc7</b>	<b>Arc8</b>	<b>Arc9</b>
$\Delta < 30000$	$f_4$	0,18	0,22	0,26	0,3	0,36	0,42	0,47	0,5
	$P_0$ , kW	0	370	740	2200	3100	4000	5300	7500
$\Delta \geq 30000$	$f_4$	0,11	0,13	0,15	0,2	0,22	0,24	0,25	0,26
	$P_0$ , kW	2100	3070	4040	5200	7300	9400	11600	14700

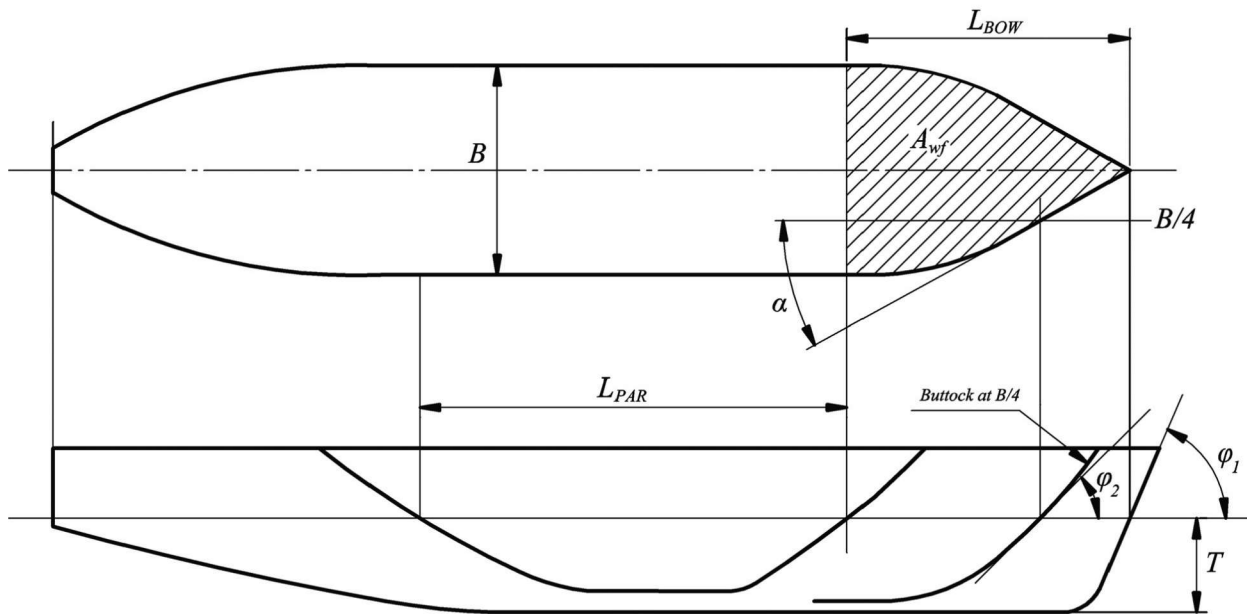

Fig. 2.1.1.4 Geometrical features of the ship for determination of the power delivered to the propeller shaft of ice class ships

Table 2.1.1.4-1

Values of coefficient $K_e$		
Number of propellers	Propulsion plant with controllable pitch propeller or electric drive	Propulsion plant with fixed pitch propeller
1	2,03	2,26
2	1,44	1,60
3	1,18	1,31

Table 2.1.1.4-2

Applicability conditions of Formula (2.1.1.4-1)

Parameter	Minimum value	Maximum value
$\alpha$ , degree	15	55
$\phi_1$ , degree	25	90
$\phi_2$ , degree	10	90
$L$ , m	65,0	250,0
$B$ , m	11,0	40,0
$T$ , m	4,0	15,0
$L_{BOW}/L$	0,15	0,40
$L_{PAR}/L$	0,25	0,75
$D_p/T$	0,45	0,75
$A_{wf}/(L \cdot B)$	0,09	0,27

2.1.1.5 The minimum power values may be reduced subject to the technical substantiation submitted to the Register in each particular case.

2.1.2 In icebreakers and Arc6 to Arc9 ice class ships, turbines and internal combustion engines with mechanical transmission of power to the propeller may be utilized as main engines, provided use is made of the devices to protect turbines, reduction gears of gas-turbine geared sets and diesel-engine geared sets against the loads exceeding the design torque determined with regard to operation of such ships

under ice conditions in compliance with the requirements of 4.2.3.2, Part IX "Machinery".

2.1.3 Propulsion plant shall provide sufficient astern power to maintain manoeuvring of the ship in all normal service conditions.

2.1.4 Propulsion plant shall be capable of maintaining in free route astern at least 70 per cent of rated ahead speed for a period of at least 30 min.

By the rated ahead speed is meant a speed corresponding to the maximum continuous power of the main machinery.

The astern power shall be sufficient to take way off a ship making a full ahead speed on an agreeable length, which must be confirmed during trials.

2.1.5 In propulsion plants with reversing gears or CP-propellers as well as in electric propulsion plants, precautions shall be taken against possible overload of main engines in excess of permissible values.

2.1.6 Means shall be provided to ensure that the machinery may be brought into operation from the dead ship condition without external aid (refer to 16.2.3, Part VIII "Systems and Piping").

On ships where internal combustion engines are started by compressed air, the set of equipment for starting shall ensure the supply of air in quantity sufficient for the initial start without external aid.

Where the ship is not fitted with an emergency generator, or an emergency generator does not comply with the requirements specified under 2.9.4, Part IX "Machinery", the means for bringing main and auxiliary machinery into operation shall be such that the initial charge of starting air or initial electrical power and any power supplies for engine operation can be developed on board ship without

Table 2.3.1-1

List, motions and trim<sup>1,2</sup>

Machinery and equipment	Steady list either way under static conditions	List either way under dynamic conditions (rolling)	Steady trim by bow or stern	Dynamic inclination by bow or stern (pitching)
Main and auxiliary machinery Emergency machinery and equipment (emergency power installations, emergency fire pumps and their devices)	15,0 22,5 <sup>4</sup>	22,5 22,5 <sup>4</sup>	5,0 <sup>3</sup> 10,0	7,5 10,0
<sup>1</sup> Steady list and trim shall be taken into account simultaneously. Rolling and pitching are also to be considered simultaneously. <sup>2</sup> On agreement with the Register, the values of inclinations may be altered depending on the type and dimensions of the ship and its service conditions as well. <sup>3</sup> Where the length of the ship exceeds 100 m, the static trim by bow or stern may be taken as $(500/L)^\circ$ where $L$ is the length of the ship, in m, as defined in 1.1.3, Part II "Hull". <sup>4</sup> In gas carriers and chemical tankers emergency power sources shall remain operative when the ship is listed up to 30 deg.				

external aid. If for this purpose an emergency air compressor or an electric generator is required, the machinery shall be powered by a hand-starting ICE or a hand-operated compressor.

The emergency generator and other means needed to restore the propulsion shall have a capacity such that the necessary propulsion starting energy is available within 30 min of black out/dead ship condition (refer to 1.2).

Emergency generator stored starting energy shall not be directly used for starting the propulsion plant, the main source of electrical power and/or other essential auxiliaries (emergency generator excluded).

For steam ships, the 30 min time limit may be interpreted as time from black out/dead ship condition to light-off of the first boiler.

**2.1.7** In the event of failure of one or all turbochargers (refer to 2.5.1, Part IX "Machinery") the machinery installation with one main internal combustion engine shall provide the ship speed at which the steerability of the ship is maintained. The main engine shall provide not less than 10 per cent of the rated power.

**2.1.8** The power of main machinery in ships of river-sea navigation shall provide the ahead speed in load condition of at least 10 knots in calm water.

**2.1.9** Supercharged high-speed engines (over 750 rpm), which increased noise level makes direct local control difficult, may be admitted by the Register for use as main engines in sea-going ships, if provision is made for remote control and monitoring so that constant presence of the attending personnel in the engine room will not be necessary.

The control and monitoring facilities shall comply with the requirements of Part XV "Automation".

**2.1.10** In the case of ships with twin hulls, the failure of the machinery installation of one hull will not put the machinery installation of the other hull out of action.

**2.1.11** Long run of the propulsion plant at all specified rates during its operation under the conditions corresponding to the assigned class shall not

lead to the overload. Technically substantiated power supply shall be provided.

**2.1.12** Propulsion plants and auxiliary machinery of passenger ships having length, as defined in 1.2.1 of the Load Line Rules for Sea-Going Ships, of 120 m or more or having three or more main vertical zones, shall comply with the requirements of 2.2.6.7.1 and 2.2.6.8, Part VI "Fire Protection".

## 2.2 NUMBER OF MAIN BOILERS

**2.2.1** In general, not less than two main boilers shall be fitted in ships of unrestricted service. Using a steam power plant with one main boiler may be permitted provided the technical substantiation is submitted to the Register.

## 2.3 ENVIRONMENTAL CONDITIONS

**2.3.1** The machinery, equipment and systems installed in the ship shall remain operative under environmental conditions stated in Tables 2.3.1-1 and 2.3.1-2, unless provided otherwise in the other parts of the Rules.

Table 2.3.1-2

## Air temperature

Installed location	Temperature range, °C
In enclosed spaces	0 to + 45
Machinery or boilers in spaces subject to temperatures exceeding 45 °C and below 0 °C	According to specific local conditions
On the open deck	-25 to + 45
Note. For ships intended for geographically restricted service other temperatures may be adopted on agreement with the Register.	

Sea water temperature is assumed to be equal to 32°C. For ships designed for geographically restricted service other temperatures may be adopted if technical substantiation is available.

#### 2.4 MATERIALS AND WELDING

**2.4.1** Materials for the manufacture of parts of the shaftings and propellers shall comply with the requirements given in the relevant chapters of Part XIII "Materials", as indicated in column 4, Table 1.3.2.3. The materials used for the components of shafting stated in item 1.7, Table 1.3.2.3 are chosen in accordance with the standards. The materials used for the components of shafting and propellers stated in items 1.2 to 1.6, 1.8, 2.2.3 and 2.3, Table 1.3.2.3 may also be chosen in accordance with the relevant standards. In such case, the application of materials shall be agreed with the Register when examining the technical documentation.

Materials used for the components (semi-finished products) indicated in items 1.1, 2.1, 2.2.1 and 2.2.2, Table 1.3.2.3 shall be surveyed by the Register during manufacture; survey of materials used for other components in said Table may be required at the option of the Register.

**2.4.2** Intermediate, thrust and propeller shafts shall generally be made of steel with tensile strength  $R_m$  between 400 and 800 MPa.

**2.4.3** The mechanical properties and chemical composition of materials used for the manufacture of propellers shall be in compliance with 3.12 and 4.2, Part XIII "Materials". Whereas steel of martensitic grade is permitted for the manufacture of propellers for ships of all types, steel of austenitic grade is permitted for the manufacture of propellers for ships without ice strengthening. The possibility to use carbon steel for the manufacture of propellers shall be agreed with the Register considering the requirements of 3.8, Part XIII "Materials".

Copper alloys of Type CU3 and Type CU4 are admitted for propellers in all ships, except icebreakers and Arc7 to Arc9 ice class ships; copper alloys of Type CU1 and Type CU2 may be used exclusively for propellers in ships of ice classes Ice1 to Ice3.

**2.4.4** Where it is intended to make shafting and propellers of alloy steels, including corrosion-resistant and high strength steels, data on chemical composition, mechanical and special properties,

confirming suitability of the steel for intended application, shall be submitted to the Register.

**2.4.5** Intermediate, thrust and propeller shafts as well as coupling bolts (studs) may be made of rolled steel in accordance with 3.7.1, Part XIII "Materials".

**2.4.6** Securing and locking items of propeller blades, hub cones, sterntubes, sternbushes and sealings shall be made of corrosion-resistant materials.

**2.4.7** Welding procedure and non-destructive testing of welded joints shall comply with the requirements of Part XIV "Welding".

**2.4.8** For all ships, new installation of materials which contain asbestos shall be prohibited in machinery installations, machinery and equipment covered by the requirements of Part VI "Fire Protection", Part VII "Machinery Installations", Part VIII "Systems and Piping", Part IX "Machinery", Part X "Boilers, Heat Exchangers and Pressure Vessels" and Part XII "Refrigerating Plants".

#### 2.5 INDICATING INSTRUMENTS

**2.5.1** All the indicating instruments, with the exception of liquid-filled thermometers, shall be checked by competent bodies.

Pressure gauges fitted on boilers, heat exchangers, pressure vessels and refrigerating plants shall meet the requirements of 3.3.5 and 6.3.8, Part X "Boilers, Heat Exchangers and Pressure Vessels" and 7.1, Part XII "Refrigerating Plants", respectively.

**2.5.2** The tachometer accuracy shall be within  $\pm 2,5$  per cent. With restricted speed ranges, the accuracy shall not be below 2 per cent, and the ranges shall be marked with bright colour on the scales of tachometers or in another way.

#### 2.6 APPLICATION OF THE RELIABILITY MEASURES OF THE MACHINERY INSTALLATIONS

**2.6.1** The reliability measures are established and specified during design and/or order of the machinery installation components by agreement of the appropriate technical documentation between the customer (shipowner) and the designer or supplier. The specific list of the reliability measures to be determined shall be established for each type of products with regard to the peculiarities of its application, failure effects, maintenance and repair system adopted.

### 3 CONTROL DEVICES AND STATIONS. MEANS OF COMMUNICATION

#### 3.1 CONTROL DEVICES

**3.1.1** Main and auxiliary machinery essential for the propulsion, control and safety of the ship shall be provided with effective means for its operation and control. All control systems essential for the propulsion, control and safety of the ship shall be independent or so designed that failure of one of them does not degrade the performance of another.

**3.1.2** The starting and reversing arrangements shall be so designed and placed that each engine can be started or reversed by one operator.

**3.1.3** Proper working direction of control handles or handwheels shall be clearly indicated by arrows and relevant inscriptions.

**3.1.4** The setting of manoeuvring handle in the direction from, or to the right of, the operator, or turning the handwheel clockwise, when controlling the main engines from the navigation bridge, shall correspond to the ahead speed direction of the ship.

In the case of control stations, from which only the stern is visible, such a setting shall correspond to the direction of astern speed of the ship.

**3.1.5** Control arrangements shall be so designed as to eliminate the possibility of spontaneously changing the positions prescribed.

**3.1.6** The control devices of main engines shall have an interlocking system to preclude starting of the main engine, with a mechanical shaft-turning gear engaged.

**3.1.7** It is recommended to provide an interlocking system between the engine-room telegraph and the reversing and starting arrangements so as to prevent the engine from running in the direction opposite to the prescribed one.

**3.1.8** The main engine remote control system, with control from the bridge, shall be designed so as to provide an alarm in the event of failure. As far as practicable, the present propeller speed and thrust direction shall remain unchanged until control is transferred to a local station. Among other factors, the loss of power supply (electric, pneumatic or hydraulic power) shall not substantially affect the power of main engines or change the direction of propeller rotation.

**3.1.9** The propulsion machinery remote control system with control from the wheel house shall be independent from the other order transmission system; however, one manoeuvring handle for systems may be accepted.

**3.1.10** It shall be possible to control the propulsion machinery from the local control station, in the

event of a failure of any unit of the remote control system.

**3.1.11** For ships of river-sea navigation the duration of reversing (a period of time from the reversing of a steering control to the beginning of propeller operation with a thrust opposite in direction) shall not exceed:

25 s at full speed;

15 s at slow speed;

depending on the ship's speed.

#### 3.2 CONTROL STATIONS

**3.2.1** The bridge control stations of main engines and propellers, as well as the main machinery control room, with any type of remote control, shall be equipped with:

**.1** controls for the operation of main engines and propellers. For installations comprising CP-propellers, vertical axis and similar type propellers, the navigation bridge may be equipped with means for remote control of propellers only. In such case, the alarm for low pressure of starting air, prescribed by 3.2.1.10, need not be provided;

**.2** shaft speed and direction indicators if a fixed pitch propeller is installed; shaft speed and blade position indicators if the controllable pitch propeller is installed; main engines speed indicator if the disengaging coupling is provided;

**.3** indicating means to show that the main machinery and remote control systems are ready for operation;

**.4** indicating means to show which station is in control of the main propulsion machinery;

**.5** means of communication (refer to 3.3);

**.6** main engine emergency stop device, independent of the control system.

If disengaging couplings are provided for disconnection of main machinery from propellers, it is permissible that emergency shut-off of these couplings only is effected from the navigation bridge;

**.7** device to override the automatic protection covering full range of parameters except those parameters which being exceeded, may result in serious damage, complete failure or explosion;

**.8** indication for the override operation, alarms for activation of protection devices and the emergency stop;

**.9** alarm for minimum oil pressure in pitch control system; overload alarm where the main

engine operates with a CP-propeller, unless the recommendation of 6.5.3 is fulfilled;

**.10** alarm for low starting air pressure, set at a level which still permits three starting attempts of reversible main engines duly prepared for operation.

**.11** device to remote shut-off fuel oil supply to each engine for multi-engine installations in case where the fuel oil is supplied to all the engines from a single supply source (refer to 13.8.3.2, Part VIII "Systems and Piping");

**.12** speed repeater (with due regard to 3.7.3.6, Part V "Navigational Equipment" of the Rules for the Equipment of Sea-Going Ships).

**3.2.2** The control stations on the wings of navigation bridge shall be equipped with devices of waterproof construction with controlled illumination. The control stations provided on the wings of the navigation bridge need not meet the requirements of 3.2.1.3, 3.2.1.5, 3.2.1.7 to 3.2.1.10.

**3.2.3** The emergency stop devices of main engine and the overrides of automatic controls shall be so constructed that inadvertent operation of such devices is not possible.

**3.2.4** For the installations which consist of several main engines driving a single shafting, there shall be provided a common control station.

**3.2.5** With a remote control system in use, provision shall also be made for local control stations of main machinery and propellers. Where, however, mechanical linkage is fitted for remote-controlling the main engine, the local control stations may be dispensed with on agreement with the Register.

**3.2.6** Remote control of main machinery and propellers shall be performed only from one location. The transfer of control between the navigation bridge and engine room shall be possible only in the engine room and the main machinery control room. The means of transfer shall be so designed as to prevent the propelling thrust from altering significantly.

Where the control stations are arranged on the wings of navigation bridge, the remote control of the main machinery shall be possible from one control station only. Such control stations may be equipped with interconnected controls.

**3.2.7** Main engines shall be remotely operated from the wheelhouse by means of a single control element per propeller. In installations with CP-propellers, systems with two control elements may be used.

**3.2.8** The sequence of the main engine operation modes assigned from the wheelhouse, including reversal from the full ahead speed in case of emergency, shall be controlled with the time intervals admissible for main engines. The modes assigned shall be indicated at the main machinery control room and at the local control stations of the main machinery.

**3.2.9** Main machinery control rooms of floating docks shall comprise the following equipment:

**.1** controls of the pumps, including the suction and overboard discharge valves of ballast system;

**.2** recording devices for heel, trim and deflection control of the dock;

**.3** signals indicating the operation of pumps and the position ("open", "closed") of suction and discharge valves of the ballast system;

**.4** alarms on limit values of list and trim;

**.5** water level indicators of ballast compartments;

**.6** dock's communication facilities.

**3.2.10** CCR shall be located as far from the machinery spaces as practicable. Onboard the tankers the CCR shall be arranged according to 2.4.9, Part VI "Fire Protection".

Furthermore, arrangement of CCR onboard chemical tankers shall comply with the requirements of Section 3, Part II "Structure of Chemical Tanker" of the Rules for the Classification and Construction of Chemical Tankers, and for gas carriers — the requirements of Section 9, Part VI "Systems and Pipelines" of the Rules for the Classification and Construction of Gas Carriers.

**3.2.11** If CCR is provided on board the ship with assigning the distinguishing mark **CCO** (refer to 2.2.18, Part I "Classification") added to the character of classification, besides compliance with the requirements of 3.2.10, CCR shall be equipped with:

**.1** means of communication according to 3.3.2;

**.2** control means of:

**.2.1** cargo, stripping and ballast pumps;

**.2.2** fans servicing cargo area spaces or cargo holds;

**.2.3** remotely controlled valves of cargo and ballast systems;

**.2.4** hydraulic system pumps (if provided);

**.2.5** inert gas system;

**.2.6** pumps and valves of heeling system (if provided);

**.3** means for monitoring of:

**.3.1** pressure in cargo manifolds;

**.3.2** pressure in the manifold for vapour emission system (if provided);

**.3.3** temperature in cargo and settling tanks;

**.3.4** temperature and pressure of warming medium in the cargo heating system;

**.3.5** actual value of ship's heel, trim and draught;

**.3.6** actual value of level in the cargo and ballast tanks;

**.4** alarm devices on:

**.4.1** fire alarm;

**.4.2** exceeding of cargo temperature in cargo holds;

**.4.3** high and low levels in cargo, ballast and settling tanks;

**.4.4** extreme high level in cargo tanks;

**.4.5** exceeding of permissible pressure in cargo manifolds of vapour emission system (80 per cent of pressure for actuating of high-velocity devices);

**.4.6** exceeding the permissible fuel oil content in the discharge ballast and flushing water;

**.4.7** exceeding the permissible temperature of pump casing according to 5.2.6, Part IX "Machinery";

**.4.8** increasing of gland and bearing temperature at bulkhead penetrations of pump shafts as per 4.2.5;

**.4.9** availability of cargo in segregated ballast tanks (for chemical tankers);

**.4.10** increasing of level in the bilge ways of cargo pump rooms;

**.4.11** parameters of inert gas system in compliance with 9.16.7.6, Part VIII "Systems and Piping";

**.4.12** status of technical aids stipulated in 3.2.10;

**.4.13** low water level in deck water seal (refer to 9.16.5, Part VIII "Systems and Piping").

**3.2.12** In ships carrying liquid gas in bulk, means for monitoring and alarm shall be additionally provided in CCR to meet the requirement of Part VIII "Instrumentation" of the Rules for the Classification and Construction of Gas Carriers.

**3.2.13** In ships carrying dangerous chemical cargo in bulk, the signalling shall be additionally provided in CCR to meet the requirements of 6.6, Part VIII "Instrumentation" of the Rules for the Classification and Construction of Chemical Tankers.

### 3.3 MEANS OF COMMUNICATION

**3.3.1** At least two independent means shall be provided for communicating orders from the navigation bridge to the position in the machinery space or in the control room, from which the speed and

direction of thrust of the propellers are normally controlled.

One of these shall be an engine-room telegraph, which provides visual indication of the orders and responses both in the machinery spaces and on the navigation bridge and which is fitted with a sound signal clearly audible in any part of the engine room while the machinery is at work, and distinct in tone from all other signals in the machinery space (refer also to 7.1, Part XI "Electrical Equipment").

Appropriate means of communication shall be provided from the navigation bridge at the engine room to any other position, from which the speed or direction of thrust of the propellers may be controlled.

A single voice-communication device serving two control stations located in close proximity is permissible.

**3.3.2** Two-way communication shall be provided between the engine room, auxiliary machinery spaces and boiler room. Onboard the ships equipped with CCR, two-way communication between CCR and navigation bridge, between CCR and the spaces, where cargo and ballast pumps are located, shall be additionally provided.

**3.3.3** When installing a voice-communication device, measures shall be taken to ensure clear audibility, with the machinery at work.

**3.3.4** Main machinery control rooms of floating docks shall have means of communication in accordance with 19.8, Part XI "Electrical Equipment".

**3.3.5** In the case of ships with twin hulls, provision shall be made for voice communication between local control stations of the hulls in addition to communication between local control stations and the common control station in the wheelhouse and the main machinery control room.

## 4 MACHINERY SPACES, ARRANGEMENT OF MACHINERY AND EQUIPMENT

### 4.1 GENERAL

**4.1.1** Ventilation of machinery spaces shall comply with the requirements of 12.5, Part VIII "Systems and Piping".

**4.1.2** Machinery spaces with dual-fuel engines shall be fitted with gas concentration sensors and the ultimate concentration level alarm system.

**4.1.3** The ventilation of machinery spaces shall be sufficient under normal conditions of ship operation to prevent accumulation of oil product vapour.

### 4.2 ARRANGEMENT OF MACHINERY AND EQUIPMENT

**4.2.1** Engines, boilers, equipment, pipes and valves shall be so arranged as to provide easy access for servicing and repair; the requirements stated in 4.5.3 shall also be met.

**4.2.2** The arrangement of boilers shall be such that the distance between boilers and fuel tanks is sufficient for a free circulation of air necessary to keep the temperature of the fuel in the tanks below its flash point except as mentioned in 13.3.5, Part VIII "Systems and Piping".

**4.2.3** Where auxiliary boilers design installed in the same space with the internal combustion engines will not initiate sparks if flame is accidentally blown out from the furnace, their furnaces shall have metallic screens or other arrangements to protect the equipment of that space if flame is accidentally blown out from the furnace.

**4.2.4** The auxiliary oil-fired boilers installed on platforms or on 'tween decks in non-watertight enclosures shall be protected by oil-tight coamings at least 200 mm in height.

**4.2.5** Driving machinery of the pumps and fans in the cargo pump rooms of oil tankers, combination carriers designed for the carriage of oil products with a flash point 60 °C or less and of oil recovery vessels shall be installed in spaces fitted with mechanical ventilation and having no exits leading to the cargo pump rooms.

Driving machinery of the submerged pumps are allowed to be installed in the open deck, provided their design and location comply with the requirements of 19.2.4.1.4 and 19.2.4.9, Part XI "Electrical Equipment".

Steam engines with working temperatures not exceeding 220 °C and hydraulic motors may be installed in cargo pump rooms.

Drive shafts of pumps and fans shall be carried through bulkheads or decks in gastight sealing glands supplied with effective lubrication from outside the pump room. As far as practicable, the construction of sealing gland shall protect it against being overheated.

Those parts of gland, which may come in contact in case of eventual disalignment of drive shaft, or damage to the bearings, shall be made of such materials, which will not initiate sparks.

If bellows are incorporated in the design, they shall be subjected to test pressure before fitting.

Cargo pumps, ballast pumps and stripping pumps, installed in cargo pump-rooms, as well as in ballast pump-rooms where cargo containing equipment is fitted, and driven by shafts passing through pump-room bulkheads shall be fitted with temperature sensing devices for bulkhead shaft glands, bearings and pump cassings.

Alarm shall be initiated in the cargo control room or the pump control station.

**4.2.6** Air compressors shall be installed in such places where air is least contaminated by vapours of combustible liquids.

**4.2.7** Fuel oil units (refer to 1.2) as well as hydraulic units containing flammable liquids with working pressure above 1,5 MPa and not being a part of main and auxiliary engines, boilers, etc., shall be placed in a separate rooms with self-closing steel doors.

If it is impracticable to locate the main components of such units and systems in a separate space, special consideration shall be given with regard to shielding of the components and location, containment of possible leakages.

**4.2.8** Requirements for the arrangement of emergency diesel-generators are outlined in 9.2, Part XI "Electrical Equipment".

**4.2.9** In oil recovery ships, the internal combustion engines, boilers and equipment containing sources of ignition as well as relevant air inlets shall be installed in intrinsically safe spaces (refer to 19.2, Part XI "Electrical Equipment").

**4.2.10** A blowdown gas caps fitted with gas fuel leakage detectors shall be installed above the dual-fuel internal combustion engines (refer to 9.1, Part IX "Machinery").

### 4.3 ARRANGEMENT OF FUEL OIL TANKS

**4.3.1** In general, fuel oil tanks shall be part of the ship's structure and shall be located outside machinery spaces of category A. Where fuel oil tanks, other

than double bottom tanks, are necessarily located adjacent to or within machinery spaces of category A, their surfaces in machinery spaces shall be kept to a minimum and shall preferably have a common boundary with the double bottom tanks. Where such tanks are situated within the boundaries of machinery spaces of category A, they shall not contain fuel oil having flash point less than 60 °C. In general, the use of free standing fuel oil tanks shall be avoided.

Service fuel oil tanks shall comply with the requirements of 13.8.1, Part VIII "Systems and Piping".

**4.3.2** Where the use of free standing fuel oil tanks is permitted by the Register, they shall be placed in oil-tight spill trays, and on passenger ships and special purpose ships carrying more than 50 special personnel, outside machinery spaces of category A as well.

**4.3.3** Fuel oil tanks shall not be located immediately above the machinery and equipment with surface temperature under insulation over 220 °C, boilers, internal combustion engines, electrical equipment and, as far as practicable, shall be arranged far apart therefrom.

**4.3.4** The arrangement of fuel oil and lubricating oil tanks in way of accommodation, service and refrigerated spaces is permitted, provided they are separated by cofferdams. Dimensions and structure of cofferdams — refer to 2.7.5.2, Part II "Hull".

On the agreement with the Register and providing the initiation of special measures, it may be permitted to separate the above compartments and spaces from the tanks without cofferdams.

Arrangement of cofferdam manholes in way of accommodation and service spaces is not permitted.

#### 4.4 INSTALLATION OF MACHINERY AND EQUIPMENT

**4.4.1** The machinery and equipment constituting the propulsion plant shall be installed on strong and rigid seatings and securely attached thereto. The construction of the seatings shall comply with the requirements of 2.11, Part II "Hull".

**4.4.2** Boilers shall be installed on bearers in such a way that their welded joints do not rest on the bearer supports.

**4.4.3** To prevent shifting of boilers, provision shall be made for efficient stops and securing for rough sea; thermal expansion of boiler structures shall be taken into account.

**4.4.4** The main engines, their gears, thrust bearings of shafts shall be secured to seatings with fitted bolts throughout or in part. The bolts may be omitted, if appropriate stops are provided. Where necessary, fitted bolts shall be used to fasten auxiliary machinery to seatings.

**4.4.5** The bolts securing the main and auxiliary machinery and shaft bearings to their seatings, end nuts of shafts as well as bolts connecting the lengths of shafting shall be fitted with appropriate lockers against spontaneous loosening.

**4.4.6** Where the machinery shall be mounted on shock absorbers, the design of the latter shall be approved by the Register.

Shock absorbing fastenings of the machinery and equipment shall:

maintain vibration-proof insulation properties when the absorbed machinery and equipment are operated in the environmental conditions as per the requirement of 2.3.1;

be resistant to the corrosive mediums, temperature and various kinds of radiation;

be equipped with the yielding grounding jumper of sufficient length to prevent radio reception interference and comply with the requirements of safety engineering;

eliminate the interference for operation of other equipment, devices and systems.

**4.4.7** In case of installation of machinery, mechanical equipment, ship arrangements and their components on plastic pads or their assembly with the use of polymeric materials, their technology shall be submitted to the Register for approval. Polymeric materials used for the pads and assembly shall be agreed with the Register (refer to Section 6, Part XIII "Materials").

**4.4.8** The machinery with horizontal arrangement of the shaft shall be installed parallel to the centre line of the ship. Installing such machinery in any other direction is permitted if the construction of machinery provides for operation under the conditions specified in 2.3.

**4.4.9** The machinery for driving generators shall be mounted on the same seatings as the generators.

#### 4.5 MEANS OF ESCAPE FROM MACHINERY SPACES

**4.5.1** Means of escape from machinery spaces, including ladders, corridors, doors and hatches, shall, if not expressly provided otherwise, provide safe escape to the lifeboat and liferaft embarkation decks.

**4.5.2** All the doors as well as the covers of companionways and skylights, which may serve as means of escape from machinery spaces, shall permit of opening and closing both from inside and outside. The covers of companionways and skylights shall be marked, as appropriate, and bear a clear inscription prohibiting to stow any loads on them.

Lifts shall not be considered as forming one of the means of escape.

**4.5.3** The main and auxiliary machinery shall be so arranged as to provide passageways from the

control stations and servicing flats to the means of escape from the machinery spaces. The width of passageways shall not be less than 600 mm over the whole length. In ships of less than 1000 gross tonnage the width of passageways may be reduced to 500 mm. The width of passageways along the switchboards shall comply with the requirements of 4.6.7, Part XI "Electrical Equipment".

**4.5.4** The width of ladders serving as escape routes and the width of doors providing access to embarkation decks shall be at least 600 mm. The width of ladders in ships of less than 1000 gross tonnage may be reduced to 500 mm.

**4.5.5** In a passenger ship, each machinery space located below the bulkhead deck shall be provided with at least two means of escape, which shall comply with the requirements of either 4.5.5.1 or 4.5.5.2, as follows:

**1** the means of escape shall consist of two sets of steel ladders as widely separated as possible, leading to doors (hatches) in the upper part of the space similarly separated and satisfying the requirements of 4.5.1. One of these ladders shall be located within a protected enclosure that satisfies the requirements of 2.1.4.5, Part VI "Fire Protection", from the lower part of the space to a safe position outside the space. Self-closing fire doors of the same fire integrity standards shall be fitted in the enclosure. The ladder shall be fixed in such a way that the heat is not transferred into the enclosure through non-insulated fixing points. The protected enclosure shall have minimum internal dimensions of at least 800 × 800 mm, and shall have emergency lighting provisions;

**Notes:** 1. A "safe position" can be any space, excluding lockers and storerooms irrespective of their area, cargo spaces and spaces where flammable liquids are stowed, but including special category spaces and ro-ro spaces, from which access is provided and maintained clear of obstacles to the decks according to 4.5.1 (categories of ship's spaces (refer to Chapter 1.5, Part VI "Fire protection")).

2. Machinery spaces may include working platforms and passageways, or intermediate decks at more than one deck level. In such case, the lower part of the space shall be regarded as the lowest deck level, platform or passageway within the space. At deck levels, other than the lowest one, where only one means of escape other than the protected enclosure is provided, self-closing fire doors shall be fitted in the protected enclosure at that deck level. Smaller working platforms in-between deck levels, or only for access to equipment or components, need not be provided with two means of escape.

3. A protected enclosure providing escape from machinery spaces to an open deck may be fitted with a hatch as means of egress from the enclosure to the open deck. The hatch shall have minimum internal dimensions of 800 mm x 800 mm.

4. Internal dimensions (refer to Note 3) shall be interpreted as clear width, so that a passage having diameter of 800 mm is available throughout the vertical enclosure, as shown in Fig. 4.5.5, clear of ship's structure, with insulation and equipment, if any. The ladder within the enclosure can be included in the internal dimensions of the enclosure. When protected enclosures include horizontal portions their clear width shall not be less than 600 mm (refer to Fig. 4.5.5).

**2** the means of escape shall consist of one steel ladder leading to a door (hatch) in the upper part of the space and satisfying the requirements of 4.5.1 and additionally, in the lower part of the space and in a position well separated from the ladder referred to, a steel door capable of being operated from each side and which provides access to a safe escape route from the lower part of the space in accordance with 4.5.1;

**3** all inclined ladders/stairways with open treads fitted to comply with 4.5.5.1 and 4.5.5.2 in machinery spaces being part of or providing access to escape routes but not located within a protected enclosure shall be made of steel. Such ladders/stairways shall be fitted with steel shields attached to their undersides, such as to provide escaping personnel protection against heat and flame from beneath.

**Note.** Inclined ladders/stairways in machinery spaces being part of, or providing access to, escape routes but not located within a protected enclosure shall not have an inclination greater than 60° and shall not be less than 600 mm in clear width. Such requirement need not be applied to ladders/stairways not forming part of an escape route, only provided for access to equipment or components, or similar areas, from one of the main platforms or deck levels within the spaces subject to requirements 4.5.5.

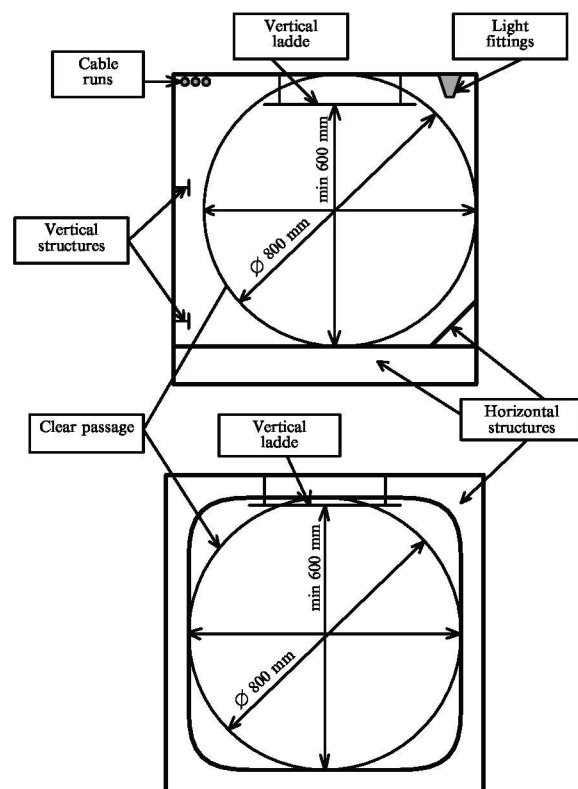

Fig. 4.5.5

**4.5.6** Where the machinery spaces in passenger ships are above the bulkhead deck, two means of escape shall be provided, which shall be as widely separated as possible, and the doors (hatches) leading from such means of escape shall be in a position satisfying the requirements of 4.5.1. Where such means of escape require the use of ladders, these shall be of steel.

**4.5.7** In passenger ships of less than 1000 gross tonnage, the Register may dispense with one of the means of escape from the spaces specified in 4.5.5 and 4.5.6, due regard being paid to the width and disposition of the upper part of the space. In ships of 1000 gross tonnage and above, the Register may dispense with one means of escape from the above mentioned spaces, including a normally unattended auxiliary machinery space, so long as the provisions of 4.5.1 are satisfied, due regard being paid to the nature of the space and whether persons are normally absent in that space.

**4.5.8** The second means of escape shall be provided from the steering gear space when the emergency steering position is located in this space unless there is a direct access to the open deck.

The local steering position located in the steering gear space is considered to be an emergency steering position if a separate emergency steering position is not provided outside steering gear.

**4.5.9** On passenger ships two means of escape shall be provided from the main machinery control room and main workshop within a machinery space. At least one of these escape routes shall provide a continuous fire shelter to a safe position outside the machinery space.

**4.5.10** In a cargo ship, at least two means of escape shall be provided from each machinery space of category A, which shall comply with the requirements of either 4.5.10.1 or 4.5.10.2, as follows:

**.1** the means of escape shall consist of two sets of steel ladders as widely separated as possible leading to doors (hatches), from which access is provided to the open deck. One of these means of escape shall be located within a protected enclosure that satisfies the requirements of 2.1.4.5, Part VI "Fire Protection", from the lower part of the space to a safe position outside the space. Self-closing fire doors of the same fire integrity standards shall be fitted in the enclosure. The ladder shall be fixed in such a way that heat is not transferred into the enclosure through non-insulated fixing points. The protected enclosure shall have minimum internal dimensions of at least 800 × 800 mm, and shall have emergency lighting provisions;

Notes: 1. A "safe position" can be any space, excluding cargo spaces, lockers and storerooms irrespective of their area, cargo pump-rooms and spaces where flammable liquids are stowed, but including vehicle and ro-ro spaces, from which access is provided and maintained clear of obstacles to the open deck (categories of ship's spaces (refer to Chapter 1.5, Part VI "Fire Protection")).

**2.** Machinery spaces of category A may include working platforms and passageways, or intermediate decks at more than one deck level. In such case, the lower part of the space shall be regarded as the lowest deck level, platform or passageway within the space.

At deck levels, other than the lowest one, where only one means of escape other than the protected enclosure is provided, self-closing fire doors shall be fitted in the protected enclosure at that deck level. Smaller working platforms in-between deck levels, or only for access to equipment or components, need not be provided with two means of escape.

**3.** A protected enclosure providing escape from machinery spaces to an open deck may be fitted with a hatch as means of egress from the enclosure to the open deck. The hatch shall have minimum internal dimensions of 800 mm x 800 mm.

**4.** Internal dimensions (refer to Note 3) shall be interpreted as clear width, so that a passage having diameter of 800 mm is available throughout the vertical enclosure, as shown in Fig. 4.5.5, clear of ship's structure, with insulation and equipment, if any. The ladder within the enclosure can be included in the internal dimensions of the enclosure. When protected enclosures include horizontal portions their clear width shall not be less than 600 mm (refer to Fig. 4.5.5).

**.2** the means of escape shall consist of one steel ladder leading to a door (hatch) in the upper part of the space, from which access is provided to the open deck and, additionally, in the lower part of the space and in a position well separated from the ladder referred to, a steel door capable of being operated from each side and which provides access to a safe escape route from the lower part of the space to the open deck;

**.3** all inclined ladders/stairways with open treads fitted to comply with 4.5.10.1 and 4.5.10.2 in machinery spaces of category A being part of or providing access to means of escape but not located within a protected enclosure shall be made of steel. Such ladders/stairways shall be fitted with steel shields attached to their undersides, such as to provide escaping personnel protection against heat and flame from beneath.

Note. Inclined ladders/stairways in machinery spaces being part of, or providing access to, escape routes but not located within a protected enclosure shall not have an inclination greater than 60° and shall not be less than 600 mm in clear width. Such requirement need not be applied to ladders/stairways not forming part of an escape route, only provided for access to equipment or components, or similar areas, from one of the main platforms or deck levels within the spaces (refer to requirements of 4.5.10);

**.4** two means of escape shall be provided from the main machinery control room and main workshop within a machinery space. At least one of these escape routes shall provide a continuous fire shelter to a safe position outside the machinery space.

**4.5.11** In cargo ships of less than 1000 gross tonnage, the Register may dispense with one of the means of escape from machinery spaces of category A, due regard being paid to the dimension and disposition of the upper part of the space. In addition, the means of escape in these ships need not comply with the requirements for an enclosure listed in paragraph 4.5.10.1.

**4.5.12** From each machinery space other than that of category A, at least two escape routes shall be provided except for spaces that are entered only occasionally, and for spaces where the maximum travel distance to the door (hatch) is 5 m or less.

*Note.* The travel distance shall be measured from any point normally accessible to the crew, taking into account machinery and equipment within the space.

**4.5.13** In addition to the requirements of 4.5.12, the steering gear space of a cargo ship shall comply with the following requirements:

**.1** steering gear spaces which do not contain the emergency steering position need only have one means of escape. The local steering position is considered to be an emergency steering position if a separate emergency steering position is not provided;-

**.2** steering gear spaces containing the emergency steering position can have one means of escape provided it leads directly onto the open deck. Otherwise, two means of escape shall be provided but they do not need to lead directly onto the open deck;

**.3** escape routes that pass only through stairways and/or corridors are considered as providing a "direct access to the open deck" if they have continuous fire shelter equivalent to steering gear spaces or stairways and corridors, whichever is greater.

**4.5.14** The escape routes from shaft tunnels and pipe ducts shall be enclosed in watertight trunks carried to above the bulkhead deck or the uppermost waterline.

Doors from shaft tunnels and pipe ducts leading in the machinery spaces and cargo pump rooms shall

comply with the requirements of 7.12, Part III "Equipment, Arrangements and Outfit".

**4.5.15** In oil tankers and combination carriers, one of the escape routes from pipe ducts situated below the cargo tanks may lead in the cargo pump room. Exit in the machinery space is not permitted.

**4.5.16** The doors and hatch covers of cargo pump rooms in oil tankers shall be capable of being opened and closed both from inside and from outside; their design shall preclude the possibility of sparking.

**4.5.17** Escape routes from cargo pump rooms shall lead directly to the open deck. Exit to other machinery spaces is not permitted.

**4.5.18** If two adjacent machinery spaces communicate through a door and each of them has only one means of escape through the casing, these means of escape shall be located at the opposite sides.

#### 4.6 INSULATION OF HEATED SURFACES

**4.6.1** Surfaces of machinery, equipment and piping with temperatures above 220 °C, which may be impinged as a result of a fuel system failure, shall be properly insulated.

**4.6.2** The insulating materials and surface of insulation shall be in accordance with the requirements of 2.1.1.5, Part VI "Fire Protection".

**4.6.3** Structural measures shall be taken to prevent any oil that may escape under pressure from any pump, filter or heater from coming into contact with heated surfaces.

## 5 SHAFTING

### 5.1 GENERAL

**5.1.1** Shafting is a solid unit connecting the engine with the propeller. Optimum location of the shafting within the ship space shall be provided to ensure rational combination of loads of the shafting components, its supports and the engine. For this a number of design, scientific, technical and engineering measures shall be taken which are unified by a concept "Shafting alignment" and approved by the Register.

**5.1.2** The minimum shaft diameters without allowance for subsequent turning on lathe during service life shall be determined by formulae given in this Section. It is assumed that additional stresses from torsional vibration will not exceed permissible values stipulated in Section 8.

Tensile strength of the shaft material shall be not less than 400 MPa and for shafts which may experience vibratory stresses close to the permissible stresses for transient operation – not less than 500 MPa.

Alternative calculation methods are permitted. These methods shall take into account criteria of static and fatigue strength and include all the relevant loads under all permissible operating conditions.

The shaft diameters determined for ships of restricted navigation areas **R2** and **R3** according to 5.2.1, 5.2.2 and 5.2.3 may be reduced by 5 per cent.

**5.1.3** In icebreakers and ice class ships, the propeller shafts shall be protected from ice effects.

**5.1.4** In ships with no obstruction for the propeller shaft to slip out of the sterntube, means shall be provided which, in the event of the propeller shaft breaking, will prevent its slipping out of the sterntube; alternative arrangements shall be made to preclude flooding of the engine room, should the propeller shaft be lost.

**5.1.5** The areas between the sterntube, strut bearing (if any) and propeller boss shall be protected by a strong casing.

### 5.2 CONSTRUCTION AND DIAMETERS OF SHAFTS

**5.2.1** The design diameter of the intermediate shaft  $d_{int}$ , in mm, shall not be less than

$$d_{int} = F \sqrt[3]{P/n} \quad (5.2.1)$$

where  $F$  = factor taken depending on the type of machinery installation as follows:

95 for installations with main machinery of rotary type or main internal combustion engines fitted with hydraulic or electromagnetic couplings;  
100 for other machinery installations with internal combustion engines;

$P$  = rated power of intermediate shaft, kW;  
 $n$  = rated speed of intermediate shaft, rpm.

**5.2.2** The diameter of thrust shaft in external bearing on a length equal to thrust shaft diameter on either side of the thrust collar and, where roller thrust bearings are used, on a length inside the housing of thrust bearing, shall not be less than 1,1 times the intermediate shaft diameter determined by Formulas (5.2.1), (5.2.4). Beyond the said lengths the diameter of the thrust shaft may be tapered to that of the intermediate shaft.

**5.2.3** The design diameter of the propeller shaft, in mm, shall not be less than that determined by the following formula:

$$d_p = 100k \sqrt[3]{P/n} \quad (5.2.3)$$

where  $k$  = factor assumed as follows proceeding from the shaft design features:

for the portion of propeller shaft between the propeller shaft cone base or the aft face of the propeller shaft flange and the forward edge of the aftermost shaft bearing, subject to a minimum of 2,5  $d_p$ ;

$k = 1,22$ , where the propeller is keyless fitted onto the propeller shaft taper or is attached to an integral propeller shaft flange;

$k = 1,26$ , where the propeller is keyed onto the propeller shaft taper;

for the portion of propeller shaft between the forward edge of the aftermost shaft bearing, or aft strut bush, and the forward edge of the forward sterntube seal  $k = 1,15$ , for all types of design.

Other terms are as defined in 5.2.1.

On the portion of propeller shaft forward of the forward edge of the forward sterntube seal the diameter of the propeller shaft may be tapered to the actual diameter of the intermediate shaft.

Where surface hardening is used, the diameters of propeller shafts may be reduced on agreement with the Register.

**5.2.4** The diameter of the shaft made of steel with tensile strength of more than 400 MPa may be determined by the following formula:

$$d_{red} = d \sqrt[3]{560/(R_{msh} + 160)} \quad (5.2.4)$$

where  $d_{red}$  = reduced diameter of the shaft, mm;  
 $d$  = design diameter of the shaft, mm;  
 $R_{msh}$  = tensile strength of the shaft material.

In all cases the tensile strength in the formula shall be assumed not exceeding 760 MPa (for carbon and carbon-manganese steel)/800 MPa (for alloyed steel) for intermediate and thrust shafts and 600 MPa for propeller shaft.

However, where materials exhibit similar fatigue life as conventional steels, special approval of alloy steel used for intermediate shaft material (refer to Appendix 2) shall be permitted.

**5.2.5** The diameters of shafts in icebreakers and ice class ships shall exceed the design diameters by value indicated in Table 5.2.5.

The diameter  $d$  of propeller shafts, in mm, for icebreakers and ice class ships (except for ships of ice class **Ice1**) shall, besides, meet the following condition in way of aft bearings:

$$d \geq a \sqrt[3]{bs^2 R_{mb} / R_e} \quad (5.2.5)$$

where  $a$  = factor equal to:  
 10,8, with propeller boss diameter equal to, or less than 0,25D ( $D$  is the propeller diameter);  
 11,5, with propeller boss diameter greater than 0,25D;  
 $b$  = actual width of expanded cylindrical section of the blade on the radius of 0,25R for unit-cast propellers and of 0,35R for CPP, m;  
 $s$  = maximum thickness of expanded cylindrical section of the blade on the radii given for  $b$ , mm;  
 $R_{mb}$  = tensile strength of the blade material, MPa;  
 $R_e$  = yield stress of propeller shaft material, MPa.

**5.2.6** If the shaft has a central hole, its bore shall not exceed 0,4 of the design diameter of the shaft.

If considered necessary, the diameter of central hole may be increased to the value obtained from the formula

$$d_c \leq (d_a^4 - 0,97d^3 d_a)^{1/4} \quad (5.2.6)$$

where  $d_c$  = diameter of central hole;  
 $d_a$  = actual shaft diameter;  
 $d$  = design diameter of the shaft without regard for central hole.

**5.2.7** Where the shaft has a radial hole, the shaft diameter shall be increased over a length of at least seven diameters of the hole. The hole shall be located at mid-length of the bossed portion of the shaft, and its diameter shall not exceed 0,3 of the shaft design diameter. In all cases, irrespective of the hole diameter, the diameter of the shaft shall be increased by not less than 0,1 times the design diameter. The edges of the hole shall be rounded to a radius not less than 0,35 times its diameter and the inside surface shall have a smooth finish.

*Note.* This para does not consider a radial hole, intersection between a radial hole and an eccentric axial bore.

**5.2.8** The diameter of a shaft having a longitudinal slot shall be increased by at least 0,2 of the

design diameter of that shaft. The diameter ratio (refer to 5.2.6) shall not exceed 0,7, the slot length shall not exceed 0,8 and slot width shall not exceed 0,15 of the design shaft diameter. Up to three slots are permitted, with consideration for their equally-spaced location.

The bossed portion of the shaft shall be of such length as to extend beyond the slot for not less than 0,25 of the design diameter of the shaft. The transition from one diameter to another shall be smooth. The ends of the slot shall be rounded to a radius of half the width of the slot and the edges — to a radius of at least 0,35 times the width; the surface of the slot shall have a smooth finish.

**5.2.9** The diameter of a shaft having a keyway shall be increased by at least 0,1 of its design diameter. After a length of not less than 0,2 of the design diameter from the ends of the keyway, no increase of the shaft diameter is required.

If the keyway is made on the outboard end of the propeller shaft, the diameter need not be increased.

Keyways are not recommended in the shafts with a barred speed range.

**5.2.10** For intermediate shafts, thrust shafts and inboard end of propeller shafts the coupling flange shall have a minimum thickness of 0,2 times the required diameter of the intermediate shaft, or the thickness of the coupling bolt diameter (refer to Formula (5.3.2)) calculated for the material having the same tensile strength as the corresponding shaft, whichever is the greater.

The thickness of coupling flange of the outboard end of propeller shaft under the bolt heads shall not be less than 0,25 times the required diameter of the shaft at the flange.

**5.2.11** The fillet radius at the base of aft flange of the propeller shaft shall not be less than 0,125 and for other flanges of shafts — shall not be less than 0,08 of the required diameter at the flange. The fillet may be formed by multiradii in such a way that the stress concentration factor will not be greater than that for a constant fillet radius.

The fillets shall have a smooth finish and shall not be recessed in way of nuts and bolt heads.

Table 5.2.5

Increase of shaft diameter, %

Shafts	Ice class ships							Icebreakers	
	Ice1, Ice2	Ice3	Arc4	Arc5	Arc6	Arc7	Arc8, Arc9	Centre shaft	Side shaft
Intermediate and thrust	0	4	8	12	13,5	15	<sup>1</sup>	18	20
Propeller	5	8	15	20	25	30	<sup>1</sup>	45	50

<sup>1</sup> It shall be agreed with the Register in each particular case.

**5.2.12** Fillet radii in the transverse section of the bottom of the keyway shall not be less than 0,0125 of the diameter of the shaft, but at least 1 mm.

**5.2.13** Where keys are used to fit the propeller on the propeller shaft cone, the latter shall have a taper not in excess of 1:12, in case of keyless fitting — according to 5.4.1.

**5.2.14** On the cone base side, the keyways in shaft cones shall be spoon-shaped, while in propeller shaft cones they shall be ski-shaped in addition.

Where the outboard end of a propeller shaft having the diameter in excess of 100 mm is concerned, the distance between the cone base and the spoon-shaped keyway end shall be at least 0,2 of the shaft diameter required, with the ratio of the keyway depth to the shaft diameter less than 0,1 and 0,5 at least of the shaft diameter required, with the ratio of the keyway depth to the shaft diameter exceeding 0,1.

In coupling shaft cones, the ski-shaped keyway end shall not extend beyond the cone base.

Where the key is secured by screws in the keyway, the first screw shall be positioned at least 1/3 of the shaft cone length from the shaft cone base. The bore length shall not exceed the propeller diameter. The bore edges shall be rounded off. Where the shaft has blind axial bores, the bore edges and end shall also be rounded off. The fillet radius shall not be less than specified in 5.2.12.

**5.2.15** Propeller shafts shall be effectively protected against exposure to sea water.

**5.2.16** Propeller shaft liners shall be made of such alloys, which possess sufficient corrosion resistance in sea water.

**5.2.17** The thickness  $s$  of a bronze liner, in mm, shall not be less than

$$s = 0,03d_p' + 7,5 \quad (5.2.17)$$

where  $d_p'$  = diameter of the propeller shaft under the liner, mm.

The thickness of the liner between the bearings may be reduced to 0,75 $s$ .

**5.2.18** Continuous liners are recommended to be used.

Liners consisting of two or more lengths shall be joined by welding or by other methods approved by the Register. The butt welded joints of the liner shall be arranged outside the region of bearings. In case of non-continuous liners the portion of the shaft between the liners shall be protected against the action of sea water by a method approved by the Register.

**5.2.19** To prevent water from reaching the propeller shaft cone, appropriate sealing shall be provided.

Structural provision shall be made for hydraulic testing of the sealing.

**5.2.20** The liners shall be shrunk on the shaft in such a way as to provide tight interference between mating surfaces. The use of pins or other parts for securing of liners to the shaft is not permitted.

### 5.3 SHAFT COUPLINGS

**5.3.1** The bolts used at the coupling flanges of shafts shall be all fitted bolts of cylindrical section.

If using coupling flanges without fitted bolts the technical substantiation shall be submitted to the Register for review.

**5.3.2** The coupling bolt diameter, in mm, shall not be less than

$$d_b = 0,65 \sqrt{\frac{d_{int}^3 (R_{msh} + 160)}{iDR_{mb}}} \quad (5.3.2)$$

where  $d_{int}$  = diameter of intermediate shaft determined by Formula (5.2.1) taking into account the ice classes requirements under 5.2.5, mm.

If the shaft diameter is increased to account for torsional vibration,  $d_{int}$  will be taken as the increased diameter of intermediate shaft;

$R_{msh}$  = tensile strength of the shaft material, MPa;

$R_{mb}$  = tensile strength of the fitted coupling bolt material, MPa, taken:

$R_{msh} \leq R_{mb} \leq 1,7R_{msh}$   
but not higher than 1000 MPa;

$i$  = number of fitted coupling bolts;

$D$  = pitch circle diameter of coupling bolts, mm.

The diameter of bolts, by which the propeller is secured to the propeller shaft flange shall be agreed with the Register in each particular case.

### 5.4 KEYLESS FITTING OF PROPELLERS AND SHAFT COUPLINGS

**5.4.1** In case of keyless fitted propellers and shaft couplings, the taper of the shaft cone shall not exceed 1:15. Provided the taper does not exceed 1:50, the shafts may be assembled with the couplings without the use of an end nut or other means of securing the coupling.

The stoppers of the end nuts shall be secured to the shaft.

**5.4.2** A keyless assembly shall generally be constructed without a sleeve between the propeller boss and the shaft.

If using constructions with intermediate sleeves the technical substantiation shall be submitted to the Register for review.

**5.4.3** When fitting the keyless shrunk assembly, the axial pull-up of the boss in relation to the shaft or intermediate sleeve, as soon as the contact area between mating surfaces is checked after eliminating

the clearance, shall be determined by the following formula:

$$\Delta h = \left[ \frac{80B}{hz} \sqrt{\left( \frac{1910PL^3}{nD_w} \right)^2 + T^2} + \frac{D_w(\alpha_y - \alpha_w)(t_e - t_m)}{z} \right] k \quad (5.4.3)$$

where  $\Delta h$  = axial pull-up of the boss in the course of fitting, cm;  
 $B$  = material and shape factor of the assembly,  $\text{MPa}^{-1}$ , determined by the formula

$$B = \frac{1}{E_y} \left( \frac{y^2 + 1}{y^2 - 1} + \nu_y \right) + \frac{1}{E_w} \left( \frac{1 + w^2}{1 - w^2} - \nu_w \right)$$

For assemblies with a steel shaft having no axial bore, the factor  $B$  may be obtained from Table 5.4.3-1 using linear interpolation;

- $E_y$  = modulus of elasticity of the boss material, MPa;
- $E_w$  = modulus of elasticity of shaft material, MPa;
- $\nu_y$  = Poisson's ratio for the boss material;
- $\nu_w$  = Poisson's ratio for the shaft material; for steel  $\nu_w = 0,3$ ;
- $y$  = mean factor of outside boss diameter;
- $w$  = mean factor of shaft bore;
- $D_w$  = mean outside shaft diameter in way of contact with the boss or intermediate sleeve (refer to Fig. 5.4.3):

without intermediate sleeve:

$$D_{w1} = D_{y1}; \quad D_{w2} = D_{y2}; \quad D_{w3} = D_{y3};$$

$$D_w = D_y;$$

with intermediate sleeve:

$$D_{w1} \neq D_{y1}; \quad D_{w2} \neq D_{y2}; \quad D_{w3} \neq D_{y3};$$

$$D_w \neq D_y;$$

$$y = \frac{D_{z1} + D_{z2} + D_{z3}}{D_{y1} + D_{y2} + D_{y3}} \text{ for the boss;}$$

$$w = \frac{D_{01} + D_{02} + D_{03}}{D_{w1} + D_{w2} + D_{w3}} \text{ for the shaft;}$$

$$D_w = (D_{w1} + D_{w2} + D_{w3})/3;$$

$$D_y = (D_{y1} + D_{y2} + D_{y3})/3;$$

- $D_y$  = mean internal boss diameter in way of contact with the shaft or intermediate sleeve, cm;
- $h$  = active length of the shaft cone or sleeve at the contact with the boss, cm;
- $z$  = taper of the boss;
- $P$  = power transmitted by the assembly, kW;
- $n$  = speed, rpm.
- $L$  = factor for ice class ships according to Table 5.4.3-2;
- $T$  = propeller thrust at ahead speed, in kN (where data are unavailable, refer to 2.2.2.6, Part III "Equipment, Arrangements and Outfit");
- $\alpha_y$  = thermal coefficient of linear expansion of the boss material,  $1/^\circ\text{C}$ ;

Table 5.4.3-1

Factor  $B \times 10^5, \text{MPa}^{-1}$ . Steel shaft  $w = 0, E_w = 2,059 \times 10^5 \text{MPa}, \nu_w = 0,3$

Factor $y$	Copper alloy boss, $\nu_y = 0,34$ with $E_y$ , MPa							Steel boss, $\nu_y = 0,3$ with $E_y = 2,059 \times 10^5$ , MPa
	$0,98 \times 10^5$	$1,078 \times 10^5$	$1,176 \times 10^5$	$1,274 \times 10^5$	$1,373 \times 10^5$	$1,471 \times 10^5$	$1,569 \times 10^5$	
1,2	6,34	5,79	5,34	4,96	4,63	4,34	4,09	3,18
1,3	4,66	4,26	3,95	3,66	3,43	3,22	3,04	2,38
1,4	3,83	3,52	3,25	3,03	2,83	2,67	2,52	1,98
1,5	3,33	3,07	2,83	2,64	2,48	2,34	2,21	1,74
1,6	3,01	2,77	2,57	2,40	2,24	2,12	2,01	1,59
1,7	2,78	2,48	2,38	2,22	2,09	1,97	1,87	1,49
1,8	2,62	2,38	2,23	2,09	1,97	1,86	1,76	1,41
1,9	2,49	2,29	2,13	1,99	1,88	1,77	1,68	1,35
2,0	2,39	2,20	2,05	1,92	1,80	1,70	1,62	1,29
2,1	2,30	2,13	1,98	1,86	1,74	1,65	1,57	1,25
2,2	2,23	2,06	1,92	1,79	1,69	1,60	1,53	1,22
2,3	2,18	2,01	1,88	1,75	1,65	1,57	1,49	1,19
2,4	2,13	1,97	1,84	1,72	1,62	1,54	1,46	1,17

Table 5.4.3-2

Factor  $L$

Assembly	Ice class ships							Icebreakers	
	Ice1, Ice2	Ice3	Arc4	Arc5	Arc6	Arc7	Arc8, Arc9	Centre shaft	Side shaft
Propeller with shaft	1,05	1,08	1,15	1,20	1,25	1,30	<sup>1</sup>	1,45	1,50
Coupling with shaft	1,0	1,04	1,08	1,12	1,135	1,15	<sup>1</sup>	1,18	1,20

<sup>1</sup> It shall be agreed with the Register in each particular case.

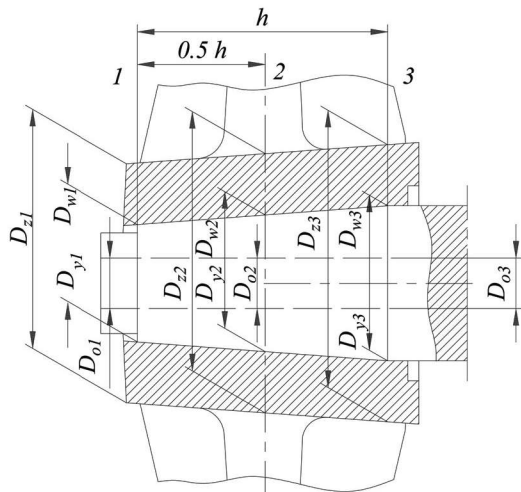

Fig. 5.4.3

- $\alpha_w$  = thermal coefficient of linear expansion of the shaft material,  $1/^\circ\text{C}$ ;  
 $t_e$  = temperature of the assembly in service conditions,  $^\circ\text{C}$ ;  
 $t_m$  = temperature of the assembly in the course of fitting,  $^\circ\text{C}$ ;  
 $k = 1$  for assemblies without intermediate sleeve;  
 $k = 1,1$  for assemblies with the use of intermediate sleeve.

For ice class ships, the value  $\Delta h$  shall be chosen as the greater of the results obtained from calculations for extreme service temperatures, i.e.:

- $t_e = 35^\circ\text{C}$  for  $L = 1$ ;  
 $t_e = 0^\circ\text{C}$  for  $L > 1$ .

In the absence of ice classes the calculation shall be made solely for the maximum service temperature  $t_e = 35^\circ\text{C}$  for  $L = 1$ .

**5.4.4** When assembling steel couplings and shafts with cylindrical mating surfaces, the interference fit shall be determined by the following formula:

$$\Delta D = \frac{80B}{h} \sqrt{\left(\frac{1910PL^3}{nD_w}\right)^2 + T^2} \quad (5.4.4)$$

where  $\Delta D$  = interference fit for  $D_w$ , cm.

Other terms are as defined in 5.4.3.

**5.4.5** For propeller bosses and half-couplings in keyless assemblies with the shafts, the following condition shall be met:

$$\frac{A}{B} \left[ \frac{C}{D_y} + (\alpha_y - \alpha_w)t_m \right] \leq 0,75R_e \quad (5.4.5)$$

where  $A$  = shape factor of the boss determined by the formula

$$A = \frac{1}{y^2 - 1} \sqrt{1 + 3y^4}.$$

The factor  $A$  may be obtained from Table 5.4.5 by linear interpolation.

- $C = \Delta h_r$  for assemblies with conical mating surfaces;  
 $C = \Delta D_r$  for assemblies with cylindrical mating surfaces;  
 $\Delta h_r$  = actual pull-up of the boss in the course of fitting at a temperature  $t_m$ , cm;  $\Delta h_r \geq \Delta h$ ;  
 $\Delta D_r$  = actual interference fit of the assembly with cylindrical mating surfaces, in cm;  $\Delta D_r \geq \Delta D$ ;  
 $R_e$  = yield stress of the boss material, MPa.

Table 5.4.5

Factor $A$			
$y$	$A$	$y$	$A$
1,2	6,11	1,9	2,42
1,3	4,48	2,0	2,33
1,4	3,69	2,1	2,26
1,5	3,22	2,2	2,20
1,6	2,92	2,3	2,15
1,7	2,70	2,4	2,11
1,8	2,54		

Other terms are as defined in 5.4.3.

## 5.5 ARRANGEMENT OF SHAFTING SUPPORTS

**5.5.1** The number of the shaftline supports, their position along the axis and in the vertical plane as well as the loads carried shall be determined on the basis of calculation made by a proven procedure agreed with the Register.

**5.5.2** The distance between the reaction forces of the adjacent shaftline bearings with no concentrated masses in span shall meet the following condition:

$$5,5a\sqrt{d} \leq l \leq a\lambda\sqrt{d} \quad (5.5.2)$$

where  $l$  = span length (distance between the reactions of adjacent supports), m;

$d$  = minimum outside shaft diameter in span, m;

$n$  = shaft speed, in rpm;

$\lambda$  = factor taken equal to:

14 when  $n \leq 500$  rpm

or  $300/\sqrt{n}$  when  $n > 500$  rpm;

$a$  = factor for bored shafts taken equal to  $\sqrt[4]{1+b^2}$ ;

$b = d_o/d$  = ratio of the bore diameter  $d_o$  to the outside shaft diameter  $d$ .

Note. Restriction on the minimum length (the left part of equation (5.5.2)) is used for all spans except for that nearest to the propeller.

**5.5.3** It is recommended to seek the minimum number of shaftline supports and the maximum possible length of the spans between them.

**5.5.4** The lengths of the spans between the shaft supports shall be checked by the bending vibration calculation.

**5.5.5** The shaftline supports shall be so installed that the engine or reduction gear components (bearings, gear wheels) take up loads within the permissible limits.

**5.5.6** The reactions of all shaftline supports shall be positive.

## 5.6 SHAFT BEARINGS

**5.6.1** The propeller shaft bearing nearest to the propeller shall meet the requirements of Table 5.6.1.

Those propeller shaft bearings, which are located forward of the bearing mentioned above, shall meet the condition

$$l \geq R/qd \quad (5.6.1)$$

where the symbols and values for  $q$  are taken from Table 5.6.1.

Table 5.6.1

Bearing material	$l/d^1$ , not less than	$q^2$ , in MPa, not more than
White metal (babbit)	2 <sup>3</sup>	1,0
Lignum vitae	4	0,25
Rubber or other synthetic water-lubricated materials approved by the Register	4 <sup>4</sup>	0,25 <sup>4</sup>
Rubber or other synthetic oil- or environment-friendly oily liquid-lubricated materials approved by the Register	2 <sup>3</sup>	1,0

<sup>1</sup> $l$  = length of bearing;  $d$  = design shaft journal diameter in way of bearing.  
<sup>2</sup> $q$  = contact pressure taken up by the bearing,  $q = R/(l \times d)$ , where  $R$  = reaction of support.  
<sup>3</sup>Length of the bearing may be reduced if the contact pressure does not exceed 0,8 MPa and if the results of the operational check are satisfactory. In all cases, the length of the bearing shall not be less than 1,5 of the actual shaft diameter in way of the bearing.  
<sup>4</sup>Length of the bearing may be reduced to twice the design shaft diameter in way of the aft bearing, provided the results of the operational check are satisfactory.

**5.6.2** The water cooling of sterntube bearings shall be of forced type (refer to 15.1, Part VIII "Systems and Piping").

The water supply system shall be provided with a flow indicator and with alarms for the minimum flow of water.

Where an open system of seawater lubrication is applied for the sternbush bearings of ships operating in shallow waters, and of specialized vessels, such as wet dredgers, suction dredgers, it is recommended that an efficient seawater cleaning device (filter, cyclone filter, etc.) shall be incorporated in the circulation system of the sternbush bearing, or sternbush bearings with mud collectors to be washed subsequently shall be fitted.

The shut-off valve controlling the supply of water to sterntube bearings shall be fitted on the sterntube or the after peak bulkhead.

**5.6.3** The oil-lubricated sternbush bearings shall be provided with forced cooling arrangements unless the after peak tank is permanently filled with water.

Indication of temperature of oil or bearing bush shall be provided.

**5.6.4** If a gravity system of lubrication is used for sternbush bearings, the lubricating oil tanks shall be fitted with oil level indicators and low level alarms.

## 5.7 STERN TUBE SEALING ARRANGEMENTS

**5.7.1** Sterntube arrangements shall be fitted with sterntube sealing arrangements providing the efficient protection against emergency intrusion of sea water inside the hull, and the environmental safety of sterntube arrangement.

**5.7.2** The minimum and the maximum permissible volumes of the refrigerant leakage into the ambient space and inside the hull shall be technically substantiated.

## 5.8 BRAKING DEVICES

**5.8.1** The shaftline shall comprise appropriate braking devices. Such devices may be a brake, a stopping or a shaft turning gear preventing rotation of the shaft in the event the main engine goes out of action.

## 5.9 HYDRAULIC TESTS

**5.9.1** Propeller shaft liners and cast sterntubes shall be hydraulically tested to a pressure of 0,2 MPa upon completion of machining. Hydraulic tests of welded and forged-and-welded sterntubes may be omitted, providing non-destructive testing of 100 per cent of welds.

**5.9.2** After assembling, the seals of the sterntube when the closed lubrication system is used shall be tested for tightness by a pressure head up to the working level of liquid in gravity tanks. In general, the test shall be carried out while the propeller shaft is turning.

## 6 PROPELLERS

### 6.1 GENERAL

**6.1.1** The requirements of this Section apply to metal fixed-pitch propellers, both solid and detachable-blade propellers, as well as to controllable-pitch propellers.

**6.1.2** The design and size of propellers of the main active means of the ship's steering shall meet the requirements of the present Section.

The scope of requirements for the design and size of propellers of the auxiliary AMSS may be reduced, subject to agreement with the Register.

### 6.2 BLADE THICKNESS

**6.2.1** Propeller blade thickness is checked in the design root section and in the blade section at the radius  $r=0,6R$  where  $R$  is propeller radius. The location of the design root section is adopted as follows:

for solid propellers — at the radius  $0,2R$  where the propeller boss radius is smaller than  $0,2R$ , and at the radius  $0,25R$  where the propeller boss radius is greater than or equal to  $0,2R$ ;

for detachable-blade propellers – at the radius  $0,3R$  where the propeller boss radius is smaller than  $0,3R$ , and at the propeller boss radius where the propeller boss radius is larger than or equal to  $0,3R$ . The values of the factors  $A$  and  $c$  are adopted as in the case of  $r = 0,25R$ ;

for CPP – at the radius  $0,35R$  where the propeller boss radius is smaller than  $0,35R$ , at the propeller

boss radius where the propeller boss radius is larger than or equal to  $0,35R$ .

Note. In the design section, the blade thickness is determined the fillets neglected.

In solid propellers, detachable-blade propellers and CPP, the maximum thickness  $s$ , in mm, of an expanded cylindrical section shall not be less than

$$s = 9,8 \left[ A \sqrt{\frac{0,14kP}{zb\sigma n}} + c \frac{m}{\sigma} \left( \frac{Dn}{300} \right)^2 \right] \quad (6.2.1-1)$$

where  $A$  = coefficient to be determined by Formula (6.2.1-2) depending on the relative radius  $r/R$  of design section and the pitch ratio  $H/D$  at this radius (for a CP-propeller, take the pitch ratio of the basic design operating condition);

$k$  = coefficient obtained from Table 6.2.1-1;

$P$  = shaft power at the rated output of the main propulsion engine, kW;

$z$  = number of blades;

$b$  = width of the expanded cylindrical section of the blade on the design radius, m;

$\sigma = 0,6R_{mbI} + 175$  MPa, but not more than 570 MPa for steels and not more than 610 MPa for copper alloys;

$R_{mbI}$  = tensile strength of blade material, MPa;

$n$  = speed at the rated output, rpm;

$c$  = coefficient of centrifugal stresses to be determined by Formula (6.2.1-3);

$m$  = blade rake, mm;

$D$  = propeller diameter, m;

$$A = \sum_{j=0}^4 \sum_{i=0}^3 a_{ij}(\bar{r})^i (H/D)^j \quad (6.2.1-2)$$

where  $a_{ij}$  = factor determined from Table 6.2.1-2;

$\bar{r}$  = relative radius of design section;

$$c = \sum_{i=0}^3 a_i(\bar{r})^i \quad (6.2.1-3)$$

where  $a_i$  = factor determined from Table 6.2.1-3;

$\bar{r}$  = relative radius of design section.

Table 6.2.1-1

Ships without ice class	Ice class ships							Icebreakers	
	Ice1, Ice2	Ice3	Arc4	Arc5	Arc6	Arc7	Arc8, Arc9	Centre propeller	Side propeller
8	9	10	11,2	12,5	13,2	14	16	16	$16 + \frac{23500}{P^1}$

<sup>1</sup> $P$  = shaft power, kW.  
 Notes: 1. If reciprocating engines with less than four cylinders are installed in the ship,  $k$  shall be increased by 7 per cent.  
 2. For reciprocating engines fitted with hydraulic or electromagnetic couplings,  $k$  may be reduced by 5 per cent.  
 3. For side propellers of ships without ice class and ships of ice classes **Ice1** and **Ice2**,  $k$  may be reduced by 7 per cent.

Table 6.2.1-2

$a_{ij}$		Values of coefficient $a_j$				
		$j$				
		0	1	2	3	4
$i$	0	709,29796	-1988,09402	2866,42279	-2021,48724	547,82587
	1	-3780,43298	14440,53576	-22809,83724	16918,28525	-4715,66016
	2	9066,98223	-36165,14189	59184,72549	-45171,89303	12819,32337
	3	-7404,99029	29254,14486	-48753,36019	37837,58962	-10848,55838

Table 6.2.1-3

$a_i$		Values of coefficient $a_i$			
		$i$			
		0	1	2	3
		0,35	2,67381	-11,71429	10,47619

The holes for the items securing the blades of built-up and CP-propellers shall not reduce the design root section.

The thickness of propeller blades in ships of river-sea navigation and in ships of restricted areas of navigation **R2** and **R3** may be reduced by 5 per cent.

**6.2.2** The blade tip thickness at the radius  $D/2$  shall not be less than provided in Table 6.2.2. The leading and trailing blade edge thickness measured at 0,05 of the blade width from the edges shall not be less than 50 per cent of blade tip thickness.

Table 6.2.2

Ships without ice classes	Ships with ice classes				Icebreakers
	Ice1 to Arc5	Arc6	Arc7	Arc8, Arc9	
0,0035D <sup>1</sup>	0,005D	0,0055D	0,006D	0,008D	0,008D

<sup>1</sup>D = diameter of the propeller.

**6.2.3** The blade thickness calculated in accordance with 6.2.1 and 6.2.2 may be reduced (e.g. for blades of particular shape), provided a detailed strength calculation is submitted for consideration to the Register.

**6.2.4** The thickness of a high-skewed ( $\theta > 25^\circ$ ) blade with an asymmetrical outline of the normal projection shall be checked in compliance with the requirements of 6.2.1. Besides, the blade thickness at the radius  $0,6R$  at a distance of 0,8 of the width of

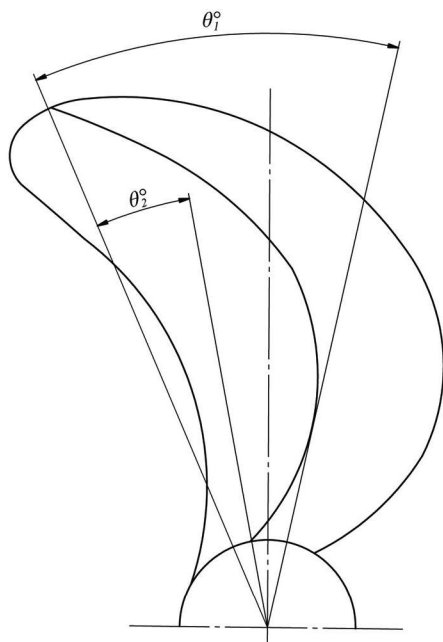

Fig. 6.2.4:

$\theta_1^\circ$  = angle between the radius drawn through the blade tip and the radius tangent to the mid-chord;  
 $\theta_2^\circ$  = angle between radii drawn through the blade tip and root section centre of the blade

section  $b$  shall not be less than determined from the following formula:

$$s_k = 0,4s(1 + 0,064\sqrt{\theta - 25}) \quad (6.2.4)$$

where  $s$  = to be determined from Formula (6.2.1) at the radius  $0,6R$ ;

$\theta$  = angle, in degrees, equal to angle  $\theta_1$  or  $\theta_2$ , whichever is the greater (refer to Fig. 6.2.4).

If smoothness of the blade section profile at the radius  $0,6R$  under condition of mandatory compliance with the requirements for the minimum thickness close to the trailing edge (on  $0,8b$ ) is not provided, thickness  $s$  at the radius  $0,6R$  is increased.

Use of high-skewed blades ( $\theta > 5^\circ$ ) for icebreakers and ice ships of **Arc7** – **Arc9** categories and of high-skewed blades ( $\theta > 10^\circ$ ) for ice ships of **Arc4** – **Arc6** categories shall be substantiated.

**6.2.5** In icebreakers and ships provided with ice strengthening, the stresses in the most loaded parts of pitch control gear shall not exceed yield stress of the material, if the blade is broken in direction of the weakest section by a force applied along the blade axis over 2/3 of its length from the boss and laterally over 2/3 from the blade spindle axis to the leading edge.

### 6.3 PROPELLER BOSS AND BLADE FASTENING PARTS

**6.3.1** Fillet radii of the transition from the root of a blade to the boss shall not be less than  $0,04D$  on the suction side of the blade and shall not be less than  $0,03D$  on the pressure side.

If the blade has no rake, the fillet radius on both sides shall be at least  $0,03D$ .

Smooth transition from the blade to the boss using a variable radius may be permitted.

**6.3.2** The propeller boss shall be provided with holes through which the empty spaces between the boss and shaft cone are filled with non-corrosive mass; the latter shall also fill the space inside the propeller cap.

**6.3.3** The diameter of the bolts (studs), by which the blades are secured to the propeller boss or the internal diameter of the thread of such bolts (studs), whichever is less, shall not be less than that determined by the following formula:

$$D_b = ks \sqrt{\frac{bR_{mbl}}{dR_{mb}}} \quad (6.3.3)$$

where  $k$  = 0,33 in case of three bolts in blade flange, at thrust surface;

0,30 in case of four bolts in blade flange, at thrust surface;

0,28 in case of five bolts in blade flange, at thrust surface;

$s$  = the maximum actual thickness of the blade at design root section (refer to 6.2.1), mm;

- $b$  = width of expanded cylindrical section of the blade at the design root section, m;  
 $R_{mbl}$  = tensile strength of blade material, MPa;  
 $R_{mb}$  = tensile strength of bolt/stud material, MPa;  
 $d$  = diameter of bolt pitch circle; with other arrangement of bolts,  $d = 0,85l$  where  $l$  = the distance between the most distant bolts, m.

**6.3.4** The securing devices of the bolts (studs), by which the blades are fastened to the detachable-blade propellers of ice class ships, shall be recessed in the blade flange.

#### 6.4 PROPELLER BALANCING

**6.4.1** The completely finished propeller shall be statically balanced.

The extent of balancing shall be checked by a test load, which when suspended from the tip of every blade in horizontal position, shall cause the propeller to rotate. The mass of the test load shall not be more than

$$m \leq km_p / R \quad (6.4.1)$$

where  $m$  = mass of test load, kg;  
 $m_p$  = mass of propeller, t;  
 $R$  = propeller radius, m;  
 $k$  = 0,75 for  $n \leq 200$ ;  
 0,5 for  $200 < n \leq 500$ ;  
 0,25 for  $n > 500$ .  
 $n$  = rated speed of propeller, rpm.

Where the propeller mass exceeds 10 t, the coefficient  $k$  shall not be greater than 0,5, irrespective of the propeller speed.

#### 6.5 CONTROLLABLE PITCH PROPELLERS

**6.5.1** The hydraulic power system of the controllable pitch propeller shall be supplied by two pumps of equal capacity, basic and standby, one of which may be driven from the main engine. The main engine driven pump shall provide turning of the blades under any operating mode of the main engines.

Where more than two pumps are available, their capacity shall be selected on the assumption that, if any of the pumps fails, the aggregate capacity of the rest would be sufficient to ensure the blade turning-over time not longer than stipulated by 6.5.5.

In ships with two CP-propellers one independent standby pump may be fitted for both CP-propellers.

**6.5.2** The pitch control unit shall be designed so as to enable turning the blades into ahead speed position, shall the hydraulic power system fail.

In multi-screw ships, except icebreakers and ships with ice strengthening of categories **Arc5** to **Arc9**, this requirement need not be satisfied.

**6.5.3** In ships with a CP-propeller, in which the main engine may become overloaded due to particular service conditions, it is recommended that automatic protection against overloading be used for the main engine.

**6.5.4** The hydraulic power system of pitch control unit shall be constructed according to the requirements of Section 7, Part IX "Machinery", and the pipes shall be tested according to Section 21, Part VIII "Systems and Piping".

**6.5.5** The time required for the blades to be turned over from full ahead to full astern speed position with main machinery inoperative shall not exceed 20 s for CP-propellers up to 2 m in diameter including, and 30 s for CP-propellers with diameters over 2 m.

**6.5.6** In the gravity lubrication systems of CP-propellers, the gravity tanks shall be installed above the deepest load waterline and be provided with level indicators and low level alarms.

#### 6.6 HYDRAULIC TESTS

**6.6.1** The sealings fitted to the cone and flange casing of the propeller shaft (if such method of connection with the propeller boss is used) shall be tested to a pressure of at least 0,2 MPa after the propeller is fitted in place. If the above sealings are under pressure of oil from the sterntube or the propeller boss, they shall be tested in conjunction with testing of the sterntubes or propeller boss.

**6.6.2** After being assembled with the blades the boss of a CP-propeller shall be tested by internal pressure equal to a head up to the working level of oil in gravity tank, or by a pressure created by the lubricating pump of the boss.

In general, the test shall be made during blade adjustment.

## 7 ACTIVE MEANS OF THE SHIP'S STEERING

### 7.1 GENERAL

**7.1.1** The requirements of the present Section apply to steerable propellers with podded drives or with mechanical transmission of power to the propeller including retractable units of all types, water-jets, vertical-axis propellers, propellers in transverse tunnel (athwartship thrusters) and other devices of similar purpose.

**7.1.2** Where AMSS is intended for main propulsion and steering of a ship, a minimum of two AMSS shall be provided.

Provision in this case shall be made for control stations equipped with necessary devices and means of communication as indicated in 2.5, 3.1 to 3.3.

Where AMSS is intended for main propulsion and steering of a ship, the technical substantiation shall be submitted to the Register for review.

**7.1.3** The type and structure of main AMSS shall be selected during ship design considering the ship purpose and area of navigation, as well as operational peculiarities.

**7.1.4** The requirements for installation of AMSS machinery and equipment, materials and welding are given in 1.3, 2.4, 4.4.

**7.1.5** For AMSS intended for the main propulsion and for the dynamic positioning, size and materials of shafts, couplings, connection bolts, propellers, gearing as well as electrical equipment shall meet the requirements of relevant parts and sections of the Rules.

All essential components used in steering arrangements for ship directional control shall be of sound reliable construction proved by appropriate calculations. Any such essential component shall, where appropriate, utilize anti-friction bearings such as ball bearings, roller bearings or sleeve bearings which shall be permanently lubricated or provided with lubrication fittings.

Moreover, the main AMSS shall comply with the applicable requirements for the steering gears, set forth in the relevant sections of the Rules.

All essential components used in steering arrangements for ship directional control shall be duplicated. When not duplicated or when the Rules contain no requirements for particular AMSS components, possibility of using them shall be agreed upon with the Register.

**7.1.6** Calculations of the AMSS gearing shall be made following the procedure outlined in 4.2, Part IX "Machinery" or by other methods recognized by the Register. The safety factors of gearing shall

not be less than those specified in 4.2, Part IX "Machinery". The values of these factors for the AMSS gearing intended for dynamic positioning duty shall be taken as for the main AMSS.

**7.1.7** To support operating capacity of AMSS till special survey the service life of the rolling bearings shall be at least:

30000 h for the main AMSS;

10000 h for the AMSS used for dynamic positioning duty;

5000 h for the auxiliary AMSS.

**7.1.8** Spaces containing the AMSS machinery shall be equipped with appropriate ventilating, fire extinguishing, drainage, heating and lighting arrangements.

### 7.2 CONSTRUCTION REQUIREMENTS

**7.2.1** Steerable propellers shall be capable to be locked in all angular positions.

**7.2.2** The main AMSS shall be provided with an emergency turning mechanism. The main AMSS angle indicator shall be provided. The difference between the indicated and actual positions shall comply with 2.9.15, Part III "Equipment, Arrangements and Outfit".

**7.2.3** In a ship fitted with main steering arrangements, such as steerable propellers, water jet propulsion systems and other propulsion systems, main and auxiliary steering gear shall be so arranged that the failure of one of them will not render the other one inoperative.

For a ship fitted with multiple steering systems, the requirement in 2.9.1, Part III "Equipment, Arrangements and Outfit" and 6.2.1.1, Part I "Machinery" is considered satisfied if each of the steering systems is equipped with its own dedicated steering gear provided that.

.1 each of the steering systems is fulfilling the requirements for main steering gear (refer to 7.2.4);

.2 each of the steering systems is provided with an additional possibility of positioning and locking the failed steering system in a neutral position after a failure of its own power unit (s) and actuator(s).

When two or more main steering systems are fitted the requirements of 5.5.2, Part XI "Electrical Equipment", shall be carried out for each of them.

**7.2.4** The main steering arrangements for ship directional control shall be:

.1 of adequate strength and capable of steering the ship at maximum ahead service speed which shall be demonstrated;

.2 capable of changing direction of the ship's directional control system from one side to the other at declared steering angle limits at an average rotational speed of not less than 2,3°/s with the ship running ahead at maximum ahead service speed (refer also to 2.9.2, Part III "Equipment, Arrangements and Outfit");

.3 for all ships, operated by power;

.4 so designed that they will not be damaged at maximum astern speed.

*Note.* Declared steering angle limits (of steerable propeller, thrust angle changing arrangement) are the operational limits in terms of maximum steering angle, or equivalent, according to manufacturer's guidelines for safe operation, also taking into account the ship's speed or propeller torque/speed or other limitation. The declared steering angle limits shall be declared by the directional control system manufacturer for each ship specific non-traditional steering mean. Ship's manoeuvrability tests shall be carried out with steering angles not exceeding the declared steering angle limits.

**7.2.5** In a ship fitted with two or more steering systems, such as but not limited to azimuthing propulsors or water jet propulsion systems, an auxiliary steering gear need not be fitted, provided that:

.1 in a passenger ship, each of the steering systems is capable of satisfying the requirements in 7.2.4.2, while any one of the power units is out of operation;

.2 in a cargo ship, each of the steering systems is capable of satisfying the requirements in 7.2.4.2 while operating with all power units;

.3 each of the steering systems is arranged so that after a single failure in its piping or in one of the power units, ship steering capability (but not individual steering system operation) can be maintained or speedily regained (e.g. by the possibility of positioning the failed steering system in a neutral position in an emergency, if needed).

The above capacity requirements apply regardless whether the steering systems are arranged with common or dedicated power units.

**7.2.6** The requirements of the present paragraph apply to the steering systems having a certain proven steering capability due to ship speed also in case propulsion power has failed. Where the propulsion power exceeds 2500 kW per thruster unit, an alternative power supply, sufficient at least to supply the steering arrangements which complies with the requirements of 7.2.14.2 and also its associated control system and the steering system response indicator, shall be provided automatically, within 45 s, either from the emergency source of electrical power or from an independent source of power located in the steering gear compartment. This

independent source of power shall be used only for this purpose. In every ship of 10000 gross tonnage and upwards, the alternative power supply shall have a capacity for at least 30 min of continuous operation and in any other ship for at least 10 min.

**7.2.7** The steerable propeller designed for reversing the thrust by turning the unit shall provide an acceptable reversing time depending on the purpose of the ship. The time required for turning the unit through 180° shall not then exceed 20 s for the units with a propeller of 2 m and less in diameter and shall not exceed 30 s for the units with a propeller of more than 2 m in diameter.

The stopping times, ship headings and distances recorded on trials, together with the results of trials to determine the ability of ships having multiple propulsion/steering arrangements to navigate and manoeuvre with one or more of these devices inoperative, shall be available on board for the use of the master or designated personnel.

**7.2.8** Sealing boxes of a type approved by the Register shall be installed to prevent sea water from gaining access to internal parts of the AMSS. For the main and for the dynamic positioning AMSS such sealing arrangement shall contain at least two separate, closely effective sealing elements.

**7.2.9** An easy access shall be provided to component parts of the AMSS to allow their maintenance within the scope stipulated by the Service Manual.

**7.2.10** Where the design of the main AMSS does not insure against free rotation of the propeller and shafting in case of failure of the prime mover, provision shall be made for a braking device in accordance with the requirements of 5.7.

On agreement with the Register, braking devices for the AMSS intended for the dynamic positioning and for the auxiliary AMSS may be dispensed with (refer also to 17.3.4, Part XI "Electrical Equipment").

**7.2.11** The strength of the parts of the main AMSS turning mechanism, casing components and securing items of the component parts, shafts, gearings, CPP components shall be so calculated that they can withstand without damage a load, which may cause breakdown of the propeller blade.

**7.2.12** Main AMSS of icebreakers and ships with ice categories **Arc4** to **Arc9** shall be provided with a device to prevent the ice overload of turning mechanism.

**7.2.13** Strength of the parts of main AMSS turning mechanism, components for securing to ship's hull shall be so calculated that they can withstand hydrodynamic and ice loads acting upon the propeller, nozzle and AMSS casing without damage. The procedure for design loads determina-

tion shall be agreed with the Register. It is permitted to determine hydrodynamic and ice loads on the AMSS components according to the results of hydrodynamic tests and testing of self-propelled models in the ice model basin according to the procedures approved by the Register.

**7.2.14** The auxiliary steering arrangements for ship directional control shall be:

**.1** of adequate strength and capable of steering the ship at navigable speed and of being brought speedily into action in an emergency;

**.2** capable of changing direction of the ship directional control system from one side to the other at declared steering angle limits at an average rotational speed, of not less than  $0,5^{\circ}/s$ ; with the ship running ahead at one half of the maximum ahead service speed or 7 knots, whichever is the greater;

**.3** for all ships, operated by power where necessary to meet the requirements of 7.2.14.2 and in any ship having power of more than 2500 kW propulsion power per thruster unit.

**7.2.15** For technical condition monitoring of the main AMSS in service, they shall be fitted with control facilities considering the requirements of Section 9 and Section 11.

The technical condition monitoring system shall combine functions of built-in (fixed) systems and portable control facilities.

A list of the technical condition monitoring system equipment, controlled parameters and frequency of their measurements, as well as standards of technical condition of the AMSS control items are developed by manufacturers and/or suppliers of the equipment.

Technical substantiation of required control of the main AMSS shall be agreed upon with the Register in each particular case.

### 7.3 ALARMS

**7.3.1** The AMSS shall be at least provided with alarms to be operated in the event of the following faults:

- .1** overload and emergency stop of prime mover;
- .2** power failure in remote control and alarm system;
- .3** low level in lubricating oil tank (if provided);

**.4** low lubricating oil pressure (if forced lubricating oil system);

**.5** low oil level in hydraulic supply system for turning steerable propellers and CP-propeller blades;

**.6** low oil level in head tank for sealing arrangements;

**.7** high level in bilge wells of the hull and AMSS spaces.

**7.3.2** Individual indication units shall be provided on the bridge for:

**.1** overload of prime mover AMSS and servo mover for steerable propellers (if no automatic protection is provided);

**.2** frequency of the propeller rotation, vertical-axis propeller or water jet impeller;

**.3** blade turning angle or propeller pitch for CP-propeller plants;

**.4** direction of thrust for fixed propeller plants, vertical-axis propeller or water jet;

**.5** angular position of steerable propeller, water jet steering and reversing gear or vertical-axis propeller eccentricity;

**.6** available power in the alarm system.

**7.3.3** For auxiliary AMSS the number of parameters covered by the alarm system and indicator units may be reduced subject to agreement with the Register.

### 7.4 HYDRAULIC TESTS

**7.4.1** Once assembled, the internal parts of the unit casing shall be subjected to test hydraulic pressure corresponding to the maximum operational depth of immersion with an allowance made for the overpressure of the sealing arrangements. For water-jet propellers pressure generated by water head shall be considered in case of reversing.

**7.4.2** Once installed, the sealing arrangements shall be subjected to leak testing by pressure equal to the height of a liquid column in head tanks at an operational level.

**7.4.3** In addition, it may be necessary to carry out non-destructive testing of welds on the steerable propeller components and other welded structures within the scope of requirements set forth in Part XIV "Welding".

## 8 TORSIONAL VIBRATION

### 8.1 GENERAL

**8.1.1** The present Section applies to propulsion plants with the main engines having a power of not less than 75 kW when ICE are used and of not less than 110 kW when using turbo or electric drives, and to auxiliary diesel generators as well as to ICE-driven machinery having a primary engine power of not less than 110 kW.

**8.1.2** Torsional vibration calculations shall be prepared both for the basic variant and for other variants and conditions possible in the operation of the installation, as follows:

**.1** maximum power take-off and idling speed (with the propeller blades at zero position) for installations comprising CP-propellers or vertical axis propellers;

**.2** individual and simultaneous operation of main engines with a common reduction gear;

**.3** reverse gear;

**.4** connection of additional power consumers if their moments of inertia are commensurate with the inertia moments of the working cylinder;

**.5** running with one cylinder misfiring, for installations containing flexible couplings and reduction gear; to be assumed not firing is the cylinder the disconnection of which accounts to the greatest degree for the increase of stresses and alternating torques;

**.6** damper jammed or removed where single main engine installations are concerned;

**.7** flexible coupling blocked due to breakage of its elastic components (where single main engine installations are concerned).

**8.1.3** For ships of restricted area of navigation **R3**, calculations stipulated by 8.1.2.6 and 8.1.2.7 are not necessary.

No calculations shall be submitted if it is documented that the installation is similar to that approved earlier or that its mass inertia moments and torsion stiffness between masses do not differ from the basic ones by 10 per cent and 5 per cent accordingly or the calculation may be limited to determination of the natural frequencies if at this stage of the calculation it is established that the differences in the mass inertia moments and torsion stiffness between masses do not result in change of the natural frequency of any one of the modes under consideration by more than 5 per cent.

**8.1.4** Torsional vibration calculations shall include:

**.1** details of all the installation components: particulars of engine, propeller, damper, flexible coupling, reduction gear, generator, etc.;

speeds corresponding to the principal long-term operating conditions specified for operation under partial loads (half speed, slow speed, dead slow speed, trawling operation, zero-speed operation for installations comprising CP-propellers, main diesel generator conditions, etc.);

layouts of all installation operating conditions possible;

initial data for the design torsional diagram of the installation;

**.2** natural frequency tables for all basic modes of vibration having a resonance up to the 12th order inclusive within the speed range  $(0 - 1,2)n_r$ , with relative vibration amplitudes of masses and moments, and with scales of stresses (torques) for all sections of the system;

**.3** for each order of all vibration modes under consideration:

resonance vibration amplitudes of the first mass of the system;

resonance stresses (torques) in all the system components (shafts, reduction gear, couplings, generators, compression or compression-key joints, etc.) and temperatures of the rubber components of flexible couplings as compared to relevant permissible values;

**.4** total stresses (torques), where it is necessary to consider the simultaneous effect of disturbing moments of several orders, as compared to relevant permissible values;

**.5** stress (torque) curves for the principal sections of the system with indication of permissible values for continuous running and rapid passage and of restricted speed ranges where these are assigned;

**.6** conclusions based on the results of calculation.

**8.1.5** The alternating torsional stress amplitude is understood as  $(\tau_{\max} - \tau_{\min})/2$  as it can be measured on a shaft in a relevant condition over a repetitive cycle.

### 8.2 PERMISSIBLE STRESSES FOR CRANKSHAFTS

**8.2.1** For main engine crankshafts of icebreakers and of ships with ice categories **Arc4** to **Arc9** within the speed range  $(0,7 - 1,05)n_r$ , and for main engine crankshafts of other types of ships and the crankshafts of engines driving generators and other auxiliary machinery for essential services within the speed range  $(0,9 - 1,05)n_r$ , the total stresses due to torsional vibration under conditions of continuous running shall not exceed the values determined by the following formulas:

when calculating a crankshaft in accordance with 2.4.5, Part IX "Machinery",

$$\tau_C = \pm \tau_N; \quad (8.2.1-1)$$

when calculating a crankshaft by another method,

$$\tau_C = \pm 0,76 \frac{R_m + 160}{18} C_d; \quad (8.2.1-2)$$

within speed ranges lower than indicated

$$\tau_C = \pm \frac{\tau_N [3 - 2(n/n_r)^2]}{1,38}; \quad (8.2.1-3)$$

or

$$\tau_C = \pm 0,55 \frac{R_m + 160}{18} C_d [3 - 2(n/n_r)^2] \quad (8.2.1-4)$$

where  $\tau_C$  = permissible stresses, MPa;

$\tau_N$  = the maximum alternating torsional stress determined during crankshaft calculation from Formula (2.4.5.1), Part IX "Machinery" for the maximum value of  $W_p$ ;

$R_m$  = tensile strength of shaft material, MPa. When using materials with the tensile strength above 800 MPa,  $R_m = 800$  MPa shall be adopted for calculation purposes;

$n$  = speed under consideration, rpm. For tugs, trawlers and other ships which main engines run continuously under conditions of maximum torque at speeds below the rated speed throughout the speed range,  $n = n_r$  shall be adopted and Formulas (8.2.1-1) and (8.2.1-2) shall be used. For the main diesel generators of ships with electric propulsion plants, all the specified values of  $n_r$  shall, by turn, be adopted as  $n$ , and in each of the ranges (0,9 — 1,05) $n_r$ , Formulas (8.2.1-3) and (8.2.1-4) shall be used for partial loads;

$n_r$  = rated speed, rpm;

$C_d = 0,35 + 0,93d^{-0,2}$  — scale factor;

$d$  = shaft diameter, mm.

**8.2.2** The total stresses due to torsional vibration within speed ranges prohibited for continuous running, but which may only be rapidly passed through shall not exceed the values determined by the following formulas:

for the crankshafts of main engines

$$\tau_T = 2\tau_C; \quad (8.2.2-1)$$

for the crankshafts of engines driving generators or other auxiliary machinery for essential services

$$\tau_T = 5\tau_C \quad (8.2.2-2)$$

where  $\tau_T$  = permissible stresses for speed ranges to be rapidly passed through, MPa;

$\tau_C$  = permissible stresses determined by one of Formulas (8.2.1-1) to (8.2.1-4).

### 8.3 PERMISSIBLE STRESSES FOR INTERMEDIATE, THRUST, PROPELLER SHAFTS AND GENERATOR SHAFTS

**8.3.1** Under conditions of continuous running, the total stresses due to torsional vibration shall not exceed the values determined by the formulas:

for the shafts of icebreakers and Arc4 to Arc9 ice class ships within the speed range (0,7 — 1,05) $n_r$ , and for

the shafts of all other ships and generator shafts within the speed range (0,9 — 1,05) $n_r$ ,

$$\tau_C = \pm 1,38 \frac{R_m + 160}{18} C_k C_d; \quad (8.3.1-1)$$

within speed ranges lower than indicated

$$\tau_C = \pm \frac{R_m + 160}{18} C_k C_d [3 - 2(n/n_r)^2] \quad (8.3.1-2)$$

where  $R_m$  = tensile strength of the shaft material, MPa. When using the material with the tensile strength over 800 MPa (for intermediate and thrust shafts of alloyed steel) and over 600 MPa (for intermediate and thrust shafts of carbon and carbon-manganese steel, as well as for propeller shaft)  $R_m = 800$  MPa and  $R_m = 600$  MPa shall be assumed in the calculations accordingly;

$C_k$  = factor obtained from Table 8.3.1; for  $C_d$ , refer to 8.2.1.

Table 8.3.1

Coefficient $C_k$		
Structural shaft type		$C_k$
Intermediate shaft, thrust shaft in external thrust bearing outside the area of roller bearing or the collar area, generator shaft	with integral coupling flanges or shrink fit couplings <sup>1</sup>	1,0
	with a radial hole (refer to 5.2.7)	0,50
	with a taper joint keyway (refer to 5.2.9)	0,60
	with a cylindrical joint keyway (refer to 5.8.9)	0,45
	with a longitudinal slot (refer to 5.2.8)	0,30 <sup>2</sup>
Thrust shaft in way of the collar or the roller thrust bearing (refer to 5.2.2)		0,85
Propeller shaft	forward sections ( $k = 1,15$ , refer to 5.2.3)	0,80
	sections in way of the aft stern-tube bearing and propeller ( $k = 1,22$ , $k = 1,26$ , refer to 5.2.3)	0,55

<sup>1</sup>when shafts may experience vibratory stresses close to the permissible stresses for continuous operation, the diameter increase in the compression joint shall be provided.  
<sup>2</sup>other  $C_k$  value may be substantiated and calculated.  $C_k = 1,45/scf$ , where  $scf$  is defined as the ratio between the maximum local principal stress and  $\sqrt{3}$  times the nominal torsional stress (determined for the bored shaft without slots).

**8.3.2** The total stresses due to torsional vibration within speed ranges prohibited for continuous running, but which may only be rapidly passed through shall not exceed:

for intermediate, thrust, propeller shafts and shafts of generators driven by the main engine

$$\tau_T = \frac{1,7\tau_C}{\sqrt{C_k}}; \quad (8.3.2)$$

for the shafts of generators driven by auxiliary engines, the value determined by Formula (8.2.2-2).

#### 8.4 PERMISSIBLE TORQUE IN REDUCTION GEAR

**8.4.1** For the case of continuous running or rapid passage, the alternating torques in any reduction gear step shall not exceed the permissible values established for the operating conditions by the manufacturer.

**8.4.2** Where the values mentioned under 8.4.1 are not available, the alternating torque in any reduction gear step for the case of continuous running shall satisfy the following conditions:

within the speed range  $(0,7 \text{ to } 1,05)n_p$  — for the main propulsion plants of icebreakers and ice class ships **Arc4** to **Arc9** and  $(0,9 \text{ to } 1,05)n_p$  — for other ships,

$$M_{alt} \leq 0,3 M_{nom}; \quad (8.4.2-1)$$

within speed ranges lower than indicated, the permissible value of alternating torque calculations shall be submitted to the Register review but in any case:

$$M_{alt} \leq 1,3 M_{nom} - M \quad (8.4.2-2)$$

where  $M_{nom}$  = average torque in the step under consideration at nominal speed, N/m;

$M$  = average torque at the speed under consideration, N/m.

For the case of rapid passage, the alternating torque value shall also be submitted to the Register review.

#### 8.5 PERMISSIBLE TORQUE AND TEMPERATURE OF FLEXIBLE COUPLINGS

**8.5.1** For the case of continuous running or rapid passage, the alternating torque in a coupling, relevant stresses in and temperatures of the flexible component material due to torsional vibration shall not exceed the permissible values established for the operating conditions by the manufacturer.

**8.5.2** Where the values mentioned under 8.5.1 are not available, the torque, stress and temperature values permissible for continuous running and rapid passage shall be determined by the procedures approved by the Register.

#### 8.6 OTHER INSTALLATION COMPONENTS

**8.6.1** Under conditions of continuous running, the total torque (average torque plus alternating torque) shall not exceed the frictional torque in the keyless fitting of the propeller and shaft or shafting couplings.

**8.6.2** Where, for generator rotors, the manufacturer's permissible values are not available, the alternating torque shall not exceed twice, in the case of continuous running, or six times, in the case of rapid passage, the nominal generator torque.

#### 8.7 TORSIONAL VIBRATION MEASUREMENT

**8.7.1** Data obtained from torsional vibration calculations for machinery installations with the main engines shall be confirmed by measurements. The measurements shall cover all the variants and operation conditions of the installation, for which calculations were made in accordance with 8.1.2, except emergency operation conditions listed in 8.1.2.6 and 8.1.2.7.

In well-grounded cases, the Register may require torsional vibrations to be measured in auxiliary diesel generators and ICE-driven auxiliary machinery for essential services.

**8.7.2** The results of measurement obtained on the first ship (unit) of a series apply to all the ships (units) of that series, provided their engine-shafting-propeller (driven machinery) systems are identical.

**8.7.3** The free resonance vibration frequencies obtained as a result of measurement shall not differ from the design values by more than 5 per cent. Otherwise, the calculation shall be corrected accordingly.

**8.7.4** The stresses shall be determined proceeding from the greatest vibration or stress amplitudes measured in the respective section of the torsigram or oscillogram.

When estimating the total stresses due to vibration of several orders, the registered parameters shall undergo harmonic analysis.

#### 8.8 RESTRICTED SPEED RANGES

**8.8.1** Where the shaft stresses, torques in some installation components or temperature of the rubber components of flexible couplings arising due to torsional vibration exceed the relevant permissible values for continuous running determined in accordance with 8.2.1, 8.3.1, 8.4 to 8.6, restricted speed ranges are assigned.

**8.8.2** No restricted speed ranges are permitted for the following speeds:

$n \geq 0,7n_r$ , with respect to icebreakers and **Arc4** to **Arc9** ice class ships;

$n \geq 0,8n_r$ , with respect to other ships;

$n = (0,9 - 1,05)n_r$ , with respect to diesel generators and other auxiliary diesel machinery for essential services. Where the main diesel generators of ships

with electric propulsion plants are concerned, all the fixed speed values corresponding to the specified conditions of partial loading shall alternately be adopted for  $n_r$ .

In icebreakers and **Arc7** to **Arc9** ice class ships fitted with a FPP, blade frequency resonance is recommended to be avoided within the range  $(0,5 - 0,8)n_r$ .

Barred speed range with one cylinder misfiring in case of one main engine on board the ship shall not influence the ship's steerability.

**8.8.3** If all the other methods of lowering stresses (torques) due to torsional vibration prove ineffective, a vibration damper or antivibrator may be fitted where the values permitted by 8.2 to 8.6 are exceeded:

in the case of continuous running, within speed ranges where restricted speed range is not permitted or undesirable;

in the case of rapid passage, in any point of the speed range  $(0 - 1,2)n_r$ .

**8.8.4** The vibration damper or antivibrator shall ensure lowering of stresses (torques) by not less than 85 per cent of the relevant permissible values at the resonance to which it is adjusted.

**8.8.5** For icebreakers and **Arc4** to **Arc9** ice class ships within the main engine speed range  $(0,7 - 1,05)n_r$  and for other ships and diesel generators within the speed range  $(0,9 - 1,05)n_r$ , vibration dampers or

antivibrators may be used to eliminate restricted speed ranges shall be agreed upon with the Register.

**8.8.6** A restricted speed range is established proceeding from the speed range, in which the stresses (torques, temperature) exceed the permissible values increased by 0,02 of  $n_{res}$  on both sides (with regard to tachometer tolerance). The engine shall be stable in operation at the barred range boundaries.

For calculation purposes, the restricted speed range borders may be determined by the following formula:

$$\frac{16n_{res}}{18 - n_{res}/n_r} \leq n \leq \frac{(18 - n_{res}/n_r)n_{res}}{16} \quad (8.8.6)$$

where  $n_{res}$  = resonance speed, rpm.

For CPP with the possibility of individual pitch and speed control, both full and zero pitch conditions shall be considered.

**8.8.7** Restricted speed ranges shall be marked off on the tachometer in accordance with 2.5.2.

Information on restricted speed ranges and their borders shall be made available on plates fastened at all the stations, from which the installation may be controlled.

**8.8.8** For the case of remote control of the main machinery from the wheelhouse, the requirements of 4.2.2.4, Part XV "Automation" shall be complied with.

## 9 VIBRATION OF MACHINERY AND EQUIPMENT. VIBRATION STANDARDS

### 9.1 GENERAL

**9.1.1** This Section sets down the limits of vibration levels (vibration standards) for ships machinery and equipment.

The standards are intended to determine whether actual vibration levels in machinery and equipment installed onboard the ships during construction (after repair) and ships in service are permissible proceeding from vibration parameter measurements. The vibration standards provide three categories of technical condition of ship machinery and equipment:

*A* — condition of machinery and equipment after manufacturing (construction of the ship) or repair at the commissioning;

*B* — condition of machinery and equipment during normal operation;

*C* — condition of machinery and equipment when technical maintenance or repair is required.

The standards determine the upper limits of categories *A* and *B*.

For machinery and equipment, not mentioned in this section but affecting the safe operation of the ship, if it is required to assess their levels of vibration, one shall be guided by the standards specified by the manufacturer, or applicable national and international standards.

**9.1.2** Vibration measurements shall be taken on all the first ships of a series being built at each shipyard, on the first ship of modified design, on the single buildings and on the ships undergone conversion.

Vibration measurements of machinery and equipment shall be taken during construction of the ship according to the program approved by the Register. Technical documentation as per the measurement results shall be submitted according to the requirements of 1.5.2, Part II "Hull".

Vibration measurements of machinery and equipment shall be performed in compliance with the instructions of 18.7, Part V "Technical Supervision during Construction of Ships" of the Rules for Technical Supervision during Construction of Ships and Manufacture of Materials and Products for Ships.

**9.1.3** During construction of the ship (or after repair) the vibration level of the machinery and equipment shall not exceed the upper limit of category *A*, determined as to ensure sufficient margin for changing of vibration level in operation.

Under conditions of long-term service of the ship the vibration level of the machinery and equipment shall not exceed the upper limit of category *B*, determined as to ensure vibration strength and reliability of ship machinery and equipment.

**9.1.4** The measurement results shall be compared with the permissible vibration levels.

Where vibration exceeds the standards, measures shall be taken to reduce it to permissible level.

**9.1.5** Vibration levels of machinery and equipment shall not exceed the standards both when the ships is lying and at specified ahead speeds under different loading conditions.

At non-specified rates of speed vibration exceeding established standards may be permitted, when these rates are not continuous.

**9.1.6** In case of withdrawal from the present standards the technical substantiation shall be submitted to the Register review.

### 9.2 STANDARDIZED VIBRATION PARAMETERS

**9.2.1** The root-mean square value of vibration rate, measured in 1/3-octave band, is assumed as the basic vibration parameter. Measuring of vibration in octave band is allowed.

**9.2.2** Alongside with the vibration rate the root-mean square value of vibration acceleration may also be a parameter measured.

**9.2.3** Vibration parameters are measured in absolute units or in decibels relatively to standard limiting values of speed or acceleration being equal to  $5 \times 10^{-5}$ , mm/s, and  $3 \times 10^{-4}$ , m/s<sup>2</sup>, accordingly.

Conversion of the measured values of vibration rate into relative units shall be made using the formula

$$L = 20 \lg \frac{v_e}{v_{eo}} \quad (9.2.3)$$

where  $v_e$  the measured root-mean square value of vibration rate, mm/s;  
 $v_{eo} = 5 \times 10^{-5}$  mm/s.

**9.2.4** When vibration is measured in octave bands, the permissible values of the parameter measured may be increased by  $\sqrt{2} = 1,41$  times (3 dB) as compared to those stated in 9.3 to 9.8 for bands with geometric mean frequency values of 2; 4; 8; 16; 31,5; 63; 125; 250 and 500 Hz.

**9.2.5** Measurements of vibration of the machinery and equipment shall be taken for each of the three inter-perpendicular direction about the ship axes: vertical, horizontal-transverse and horizontal-longitudinal. For internal combustion engines, measurements of vibration shall be taken according to direction of axes: *x* — axial (coincident with the direction of the crankshaft), *y* — horizontal-transverse, *z* — vertical. Such designation shall be applied for main diesel engines and diesel engines of diesel-

generators. The points of vibration measuring are indicated in Fig. 9.2.5.

**9.2.6** Vibration standards of machinery are specified in the relative chapters for rigid and yielding supports to which machinery can be attached under shipboard conditions.

Rigid supports are those supports where the first natural frequency of the "support — machinery" system exceeds the basic exciting frequency (working frequency of revolution) in the vibration measurement direction by more than 25 per cent.

Yielding support is a support where the first natural frequency is less than 25 per cent of the machinery working frequency of revolution.

Yielding of the support is ensured by resilient mounting of the machinery or support (vibration insulators of various design — shock absorbers, springs, rubber insulators, etc.).

The vibration standards of categories *A* and *B* for machinery installed on rigid supports are specified in the relevant tables and figures. When the machinery is attached to yielding supports, the values of permissible vibration standards are increased. To determine the values of permissible vibration rate, multiplication factor for the particular type of machinery shall be applied.

### 9.3 VIBRATION STANDARDS FOR INTERNAL COMBUSTION ENGINES

**9.3.1** Vibration standards are extended to cover ICE with 55 kW and above in power and rotation frequency  $\leq 3000 \text{ min}^{-1}$ .

**9.3.2** Vibration of low-speed internal combustion engines installed on rigid supports is considered

permissible for categories *A* and *B*, provided the root-means square values of vibration rate and vibration acceleration measured in the direction of axes *x* and *z* do not exceed the values specified in Table 9.3.2 and Fig. 9.3.2. When vibration is measured along the axis *y* (in transverse direction) the permissible vibration rate standards for categories *A* and *B* shall be increased by 1,4 times.

When the internal combustion engines are installed on yielding supports (main medium-speed diesel engines and diesel engines of diesel-generators) the permissible vibration standards for categories *A* and *B* in the direction of axes *x*, *y* and *z* specified in Table 9.3.2 and Fig. 9.3.2 shall be increased by 1,4 times.

**9.3.3** Vibration of machinery and devices hung on ICE shall not exceed the levels given in 9.3.2.

**9.3.4** Vibration of turbo-compressors measured on bearing housings is considered permissible for categories *A* and *B*, provided the root-meansquare values of vibration rate or vibration acceleration do not exceed the values specified in Table 9.3.4 and Fig. 9.3.4.

### 9.4 VIBRATION STANDARDS FOR MAIN GEARED TURBINES AND THRUST BEARINGS

**9.4.1** The running vibration of 15000 to 3000 kW horse power main geared turbines measured on the bearing housings is considered permissible for categories *A* and *B*, provided the root-means square values of vibration rate or vibration acceleration do not exceed the values specified in Table 9.4.1 and Fig. 9.4.1.

The vibration standards specified in Table 9.4.1 and Fig. 9.4.1 shall be applied to the main geared turbines when installed both on rigid and on yielding supports.

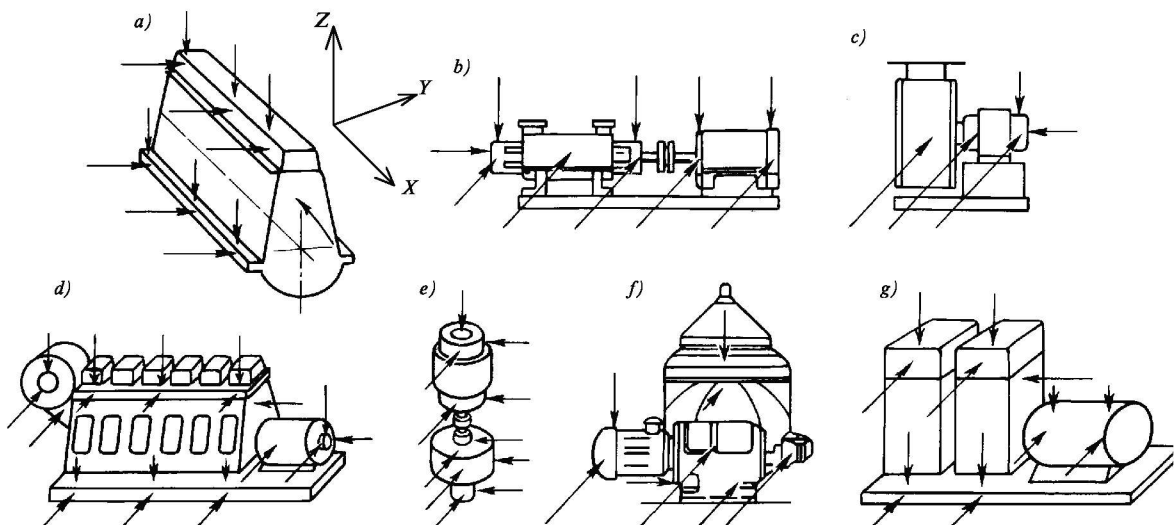

Fig. 9.2.5 Points of vibration measuring:  
*a* — internal combustion engine; *b* — horizontal pump; *c* — fan; *d* — diesel-generator;  
*e* — vertical pump; *f* — separator; *g* — piston compressor.  
 The points and directions of vibration measurement are shown by arrows

Table 9.3.2  
Vibration standards for internal combustion engines

Geometric mean frequencies of 1/3-octave bands, Hz	Engines with piston stroke, cm																			
	under 30				30 to 70				71 to 140				141 to 240				over 240			
	Permissible values of vibration rate																			
	category A		category B		category A		category B		category A		category B		category A		category B		category A		category B	
	mm/s	dB	mm/s	dB	mm/s	dB	mm/s	dB	mm/s	dB	mm/s	dB	mm/s	dB	mm/s	dB	mm/s	dB	mm/s	dB
1,6	4	98	5,6	101	4	98	5,6	101	4	98	5,6	101	4	98	5,6	101	4	98	5,6	101
2	4	98	5,6	101	4	98	5,6	101	4	98	5,6	101	4	98	5,6	101	4,5	99	6,3	102
2,5	4	98	5,6	101	4	98	5,6	101	4	98	5,6	101	4,6	99	6,3	102	5,6	101	8,0	104
3,2	4	98	5,6	101	4	98	5,6	101	4,5	99	6,3	102	5,6	101	8,0	104	7,1	103	10	106
4	4	98	5,6	101	4,5	99	6,3	102	5,6	101	8,0	104	7,1	103	10	106	8,9	105	12,5	108
5	4,5	99	6,3	102	5,6	101	8,0	104	7,1	103	10	106	8,9	105	12,5	108	11	107	16	110
6,3	5,6	101	8,0	104	7,1	103	10	106	8,9	105	12,5	108	11	107	16	110	14	109	20	112
8	7,1	103	10	106	8,9	105	12,5	108	11	107	16	110	14	109	20	112	16	110	22	113
10	8,9	105	12,5	108	11	107	16	110	14	109	20	112	16	110	22	113	16	110	22	113
12,5	11	107	16	110	14	109	20	112	16	110	22	113	16	110	22	113	16	110	22	113
16	14	109	20	112	16	110	22	113	16	110	22	113	16	110	22	113	16	110	22	113
20	16	110	22	113	16	110	22	113	16	110	22	113	16	110	22	113	16	110	22	113
25	16	110	22	113	16	110	22	113	16	110	22	113	16	110	22	113	16	110	22	113
31,5	16	110	22	113	16	110	22	113	16	110	22	113	16	110	22	113	12,5	108	18	111
40	16	110	22	113	16	110	22	113	16	110	22	113	16	110	22	113	12,5	108	14	109
50	16	110	22	113	16	110	22	113	16	110	22	113	16	110	22	113	8	104	11	107
63	16	110	22	113	16	110	22	113	12,5	108	18	111	10	106	14	109	6,3	102	8,9	105
80	12,5	108	18	111	10	106	14	109	8	104	11	107	6,3	102	8,9	105	5	100	7,1	103
100	10	106	14	109	8	104	11	107	6,3	102	8,9	105	5	100	7,1	103	4	98	5,6	101
125	8	104	11	107	6,3	102	8,9	105	5	100	7,1	103	4	98	5,6	101	3,2	96	4,5	99
160	6,3	102	8,9	105	5	100	7,1	103	4	98	5,6	101	3,2	96	4,5	99	2,5	94	3,6	97
	5	100	7,1	103	4	98	5,6	101	3,2	96	4,5	99	2,5	94	3,6	97	2	92	2,8	95

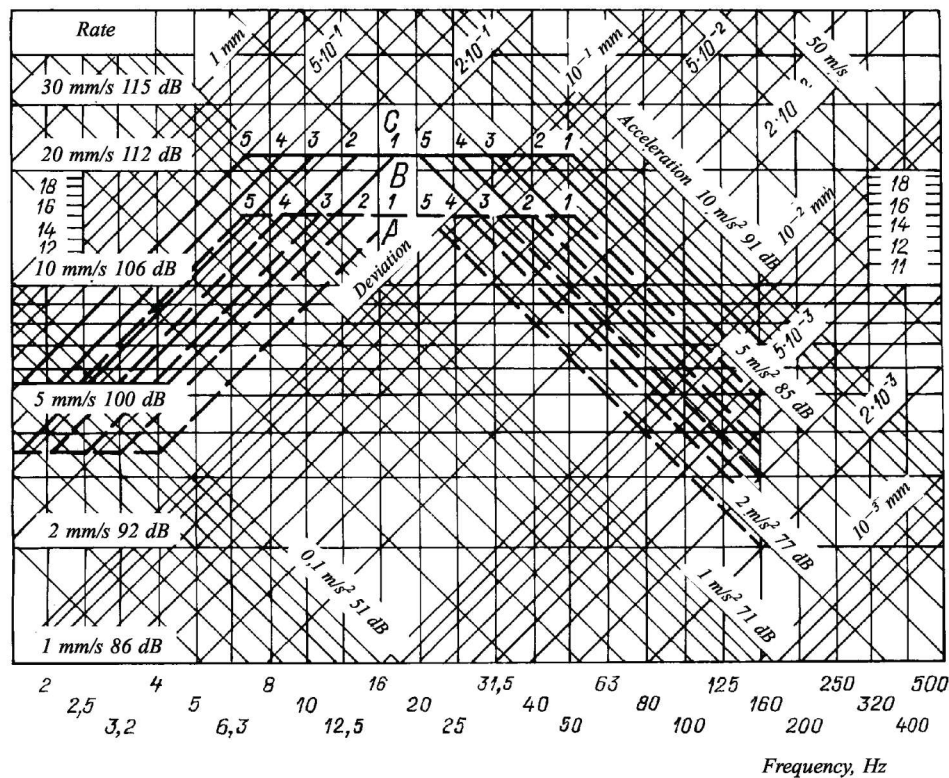

Fig. 9.3.2 Vibration standards for internal combustion engines with a piston stroke:  
 1 — under 30 cm; 2 — 30 to 70 cm; 3 — 71 to 140 cm; 4 — 141 to 240 cm; 5 — over 240 cm.  
 - - - - - Upper limit of category A; ————— Upper limit of category B

9.4.2 For main geared turbines of less than 15000 kW power the vibration standards are 3 dB lower than the values specified in Table 9.4.1 and Fig. 9.4.1.

9.4.3 Vibration of thrust bearings shall not exceed the standards given in 9.4.1 and 9.4.2.

**9.5 VIBRATION STANDARDS FOR AUXILIARY MACHINERY OF ROTARY TYPE**

9.5.1 Vibration of vertical pumps with the capacity of 15 to 75 kW, including their electric drive, is assumed permissible for categories A and B, when the root-mean square values of vibration rate and vibration acceleration do not exceed the values stated in Table 9.5.1 and in Fig. 9.5.1.

For pumps having the capacity of 2 to 15 kW the vibration standards for categories A and B are assumed being 3 dB lower compared with the vibration standards for the pumps hewing the capacity of 15 to 75 kW, and for the pumps with the capacity of 75 to 300 kW such standards shall be raised by 2 dB. Vibration standards for horizontal pumps for the above mentioned capacity range are assumed being 2 dB lower.

The vibration standards specified in Table 9.5.1 and Fig. 9.5.1 shall be applied to all pumps when installed on

Table 9.3.4  
**Vibration standards for turbo-compressors**

Geometric mean frequencies of 1/3-octave band, Hz	Permissible values of vibration rate			
	category A		category B	
	mm/s	dB	mm/s	dB
1,6	10	106	14	109
2	12,5	108	16	110
2,5	14	109	20	112
3,2	20	112	25,5	114
4	24	114	34	116
5	24	114	34	116
6,3	24	114	34	116
8	24	114	34	116
10	24	114	34	116
12,5	24	114	34	116
16	24	114	34	116
20	24	114	34	116
25	24	114	34	116
31,5	24	114	34	116
40	24	114	34	116
50	24	114	34	116
63	24	114	34	116
80	24	114	34	116
100	24	114	34	116
125	24	114	34	116
160	24	114	34	116
200	24	114	34	116
250	18	111	26	116
320	14	109	20	112
400	11	107	16	110
500	9	106	13	109

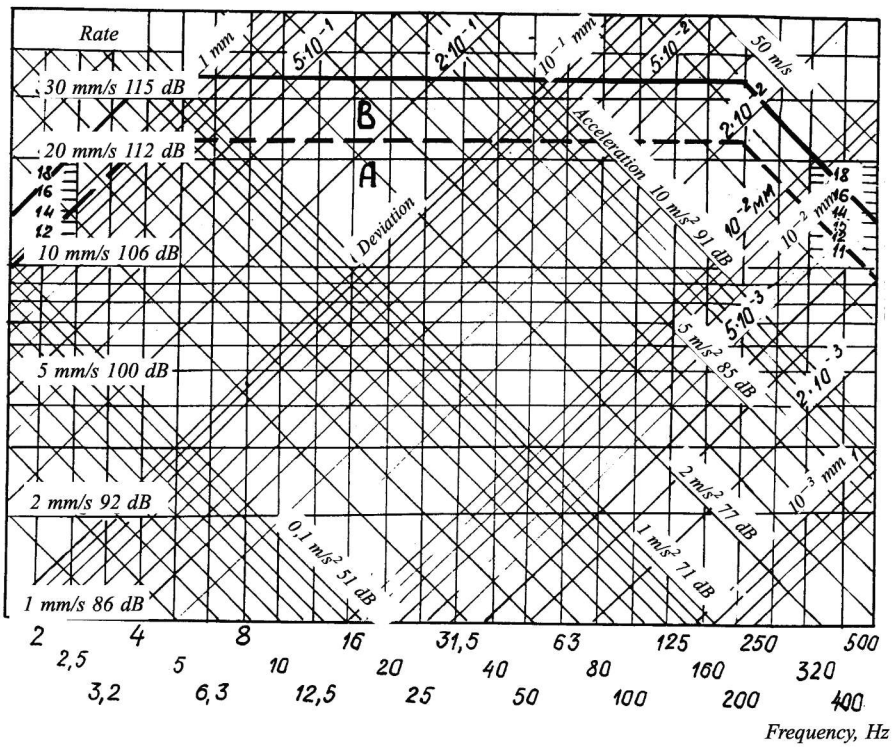

Fig. 9.3.4 Vibration standards for turbo-compressors of internal combustion engines:  
 - - - - - Upper limit of category A;      ———— Upper limit of category B

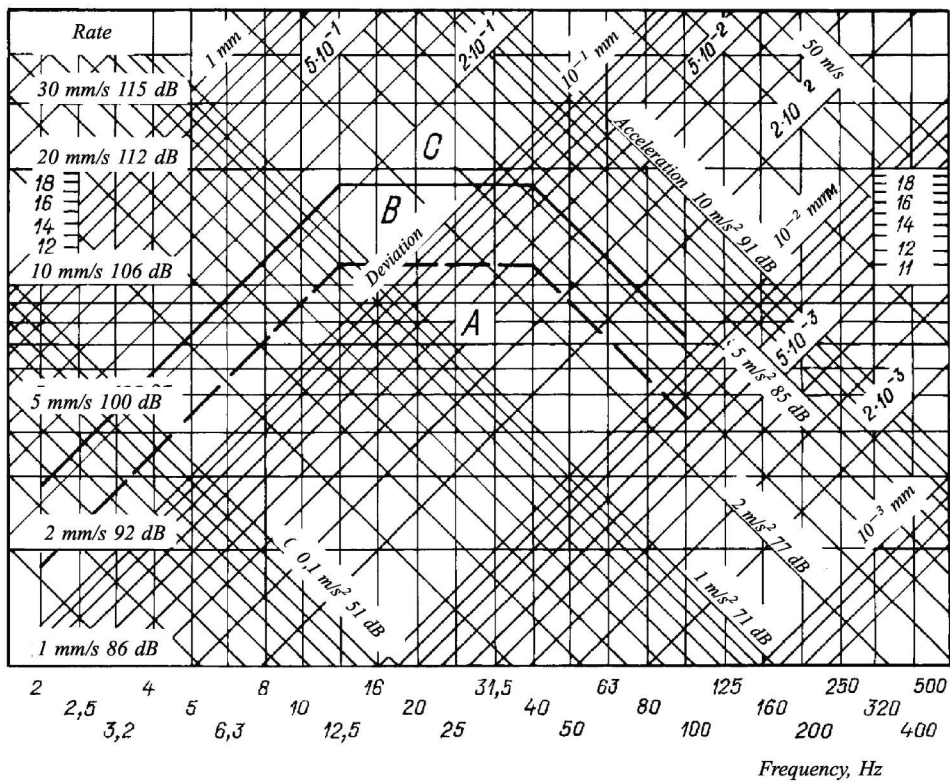

Fig. 9.4.1 Vibration standards for main steam geared turbines of 15000 to 30000 kW capacity and thrust bearings:  
 - - - - - Upper limit of category A;      ———— Upper limit of category B

Table 9.4.1

Vibration standards for main geared turbines, thrust bearings, boilers, heat exchangers, ICE-driven generators, shaft-generators, turbo-drives, turbo-generators and piston compressors

Geometric mean frequencies of 1/3-octave bands, Hz	Main geared turbines and trust bearings		Boilers and heat exchangers		ICE-driven generators, turbo-drives and turbo-generators <sup>1</sup>		Piston compressors	
	Permissible values of vibration rate				category A		category B	
	category A	category B	category A	category B	category A	category B	category A	category B
	mm/s	dB	mm/s	dB	mm/s	dB	mm/s	dB
1,6	1,5	90	2,5	94	5,6	101	1,6	90
2	1,9	92	3,1	96	5,6	101	1,9	92
2,5	2,4	94	3,8	98	5,6	101	2,4	94
3,2	3	96	4,8	100	7,1	103	3	96
4	3,7	97	6	102	8,9	105	3,7	97
5	4,6	99	7,5	104	11	107	4,6	99
6,3	5,7	101	9,3	105	14	109	5,7	101
8	7	103	11,5	107	16	110	7,1	103
10	8,8	105	14,5	109	16	110	8,9	105
12,5	11	107	18	111	16	110	11	107
16	11	107	18	111	16	110	11	107
20	11	107	18	111	16	110	11	107
25	11	107	18	111	16	110	11	107
31,5	11	107	18	111	16	110	11	107
40	11	107	18	111	16	110	11	107
50	8,8	105	14,5	109	12,5	108	11	107
63	7	103	11,5	107	10	106	11	107
80	5,7	101	9,3	105	8	104	11	107
100	4,6	99	7,5	104	—	—	11	107
125	—	—	—	—	—	—	8,9	105
160	—	—	—	—	—	—	7,1	103
200	—	—	—	—	—	—	5,7	101
250	—	—	—	—	—	—	4,6	99
320	—	—	—	—	—	—	3,7	97
400	—	—	—	—	—	—	3	96
500	—	—	—	—	—	—	—	—
							1	86
							1,3	88
							1,6	90
							2,1	92
							2,5	94
							3,2	96
							4	98
							5,1	100
							6,4	102
							8	104
							10	106
							12,5	108
							16	110
							20	110
							25	110
							31,5	110
							40	110
							50	110
							63	110
							80	110
							100	110
							125	110
							160	110
							200	110
							250	110
							320	110
							400	110
							500	110

<sup>1</sup>Refer to 9.5.4.

Table 9.5.1

Vibration standards for pumps, centrifugal separators and fans

Geometric mean frequencies of 1/3-octave bands, Hz	Pumps with the capacity of 15 to 75 kW				Centrifugal separators				Fans			
	Permissible values of vibration rate											
	category A		category B		category A		category B		category A		category B	
	mm/s	dB	mm/s	dB	mm/s	dB	mm/s	dB	mm/s	dB	mm/s	dB
1,6	1	86	1	86	1	86	1,3	88	1	86	1,3	88
2	1	86	1,2	88	1	86	1,6	90	1	86	1,6	90
2,5	1,1	87	1,4	89	1,3	88	2	92	1,3	88	2	92
3,2	1,4	89	2	92	1,6	90	2,5	94	1,6	90	2,5	94
4	1,7	91	2,5	94	2	92	3,2	96	2	92	3,2	96
5	2,2	93	3,3	96	2,5	94	4	98	2,6	94	4	98
6,3	2,7	95	4	98	3,2	96	5	100	3,3	96	5	100
8	3,5	97	5	100	4	98	6,4	102	4,1	98	6,4	102
10	4,3	99	6,3	102	5	100	8	104	5,2	100	8	104
12,5	5,5	101	8	104	5	100	8	104	6,7	103	10,3	106
16	7	103	10	106	5	100	8	104	8,5	105	13	108
20	7	103	10	106	5	100	8	104	8,5	105	13	108
25	7	103	10	106	5	100	8	104	8,5	105	13	108
31,5	7	103	10	106	5	100	8	104	8,5	105	13	108
40	7	103	10	106	5	100	8	104	8,5	105	13	108
50	7	103	10	106	5	100	8	104	8,5	105	13	108
63	7	103	10	106	5	100	8	104	6,7	103	10,3	106
80	5,5	101	8	104	5	100	8	104	5,2	100	8	104
100	4,3	99	6,3	102	5	100	8	104	4,1	98	6,4	102
125	3,5	97	5	100	4	98	6,4	102	3,3	96	5	100
160	2,7	95	4	98	3,2	96	5	100	2,6	94	4	98
200	2,2	93	3,3	96	2,5	94	4	98	2	92	3,2	96
250	1,7	91	2,5	94	2	92	3,2	96	1,6	90	2,5	94
320	1,4	89	2	92	1,6	90	2,5	94	1,3	88	2	92
400	—	—	—	—	1,3	88	2	92	1	86	1,6	90
500	—	—	—	—	1	86	1,6	90	1	86	1,3	88

rigid support. In case when the pumps are installed on yielding support, the permissible vibration standards shall be increased by 1,4 times for categories A and B.

**9.5.2** Vibration of centrifugal separators is assumed permissible for categories A and B, when the root-mean square values of vibration rate and vibration acceleration do not exceed the values stated in Table 9.5.1 and in Fig. 9.5.2.

The vibration standards are specified considering the installation of separators on shock absorbers.

**9.5.3** Vibration of fans and gas blowers of the inert gas systems is assumed permissible for categories A and B, when the root-mean square values of vibration rate and vibration acceleration do not exceed the values stated in Table 9.5.1 and in Fig. 9.5.3.

The vibration standards are specified considering the installation of fans and gas blowers on shock absorbers. In case of rigid fixing, these standards shall also be applied.

**9.5.4** Vibration of turbo-drives, turbo-generators and generators of diesel-generators with the capacity of 1000 to 2000 kW, measured on the bearing housings, is assumed permissible for categories A and B, when the root-mean square values of vibration rate and vibration acceleration do not exceed the values stated in Table 9.4.1 and in Fig. 9.5.4.

For the turbo-drives, turbo-generators and generators of diesel-generators with the capacity under 1000 kW the vibration standards for categories A and B are by 4 dB lower than the values stated in Table 9.4.1 and in Fig. 9.5.4.

The vibration standards for turbo-drives and turbo-generators shall be applied when these are installed both on rigid and on yielding supports.

The vibration standards for generators of diesel-generators when installed on yielding supports shall be doubled.

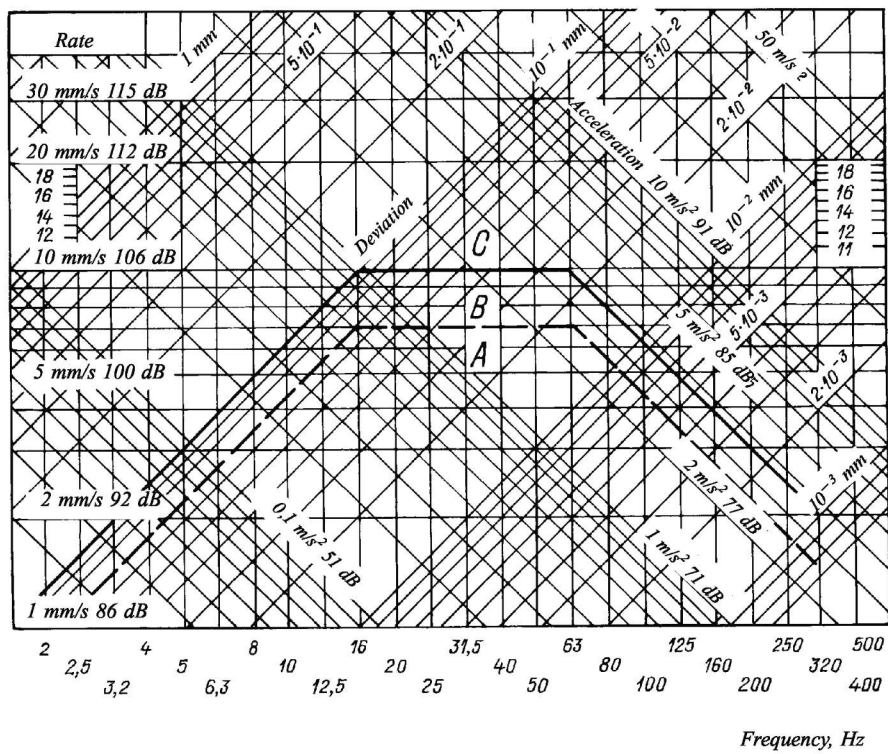

Fig. 9.5.1 Vibration standards for pumps with the capacity of 15 to 75 kW:

----- Upper limit of category A;      \_\_\_\_\_ Upper limit of category B

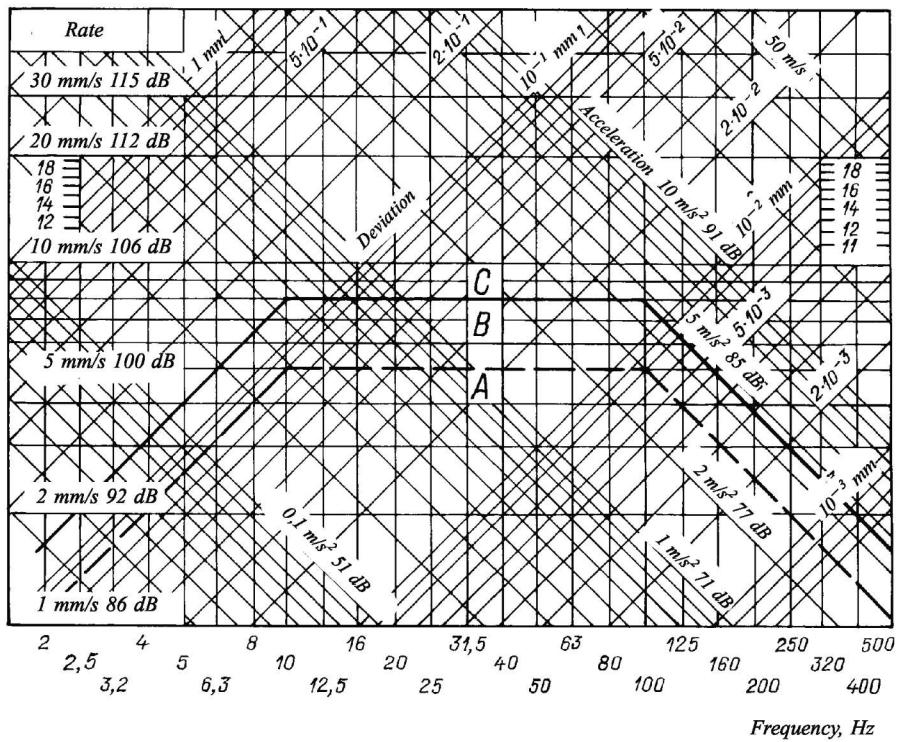

Fig. 9.5.2 Vibration standards for centrifugal separators:

----- Upper limit of category A;      \_\_\_\_\_ Upper limit of category B

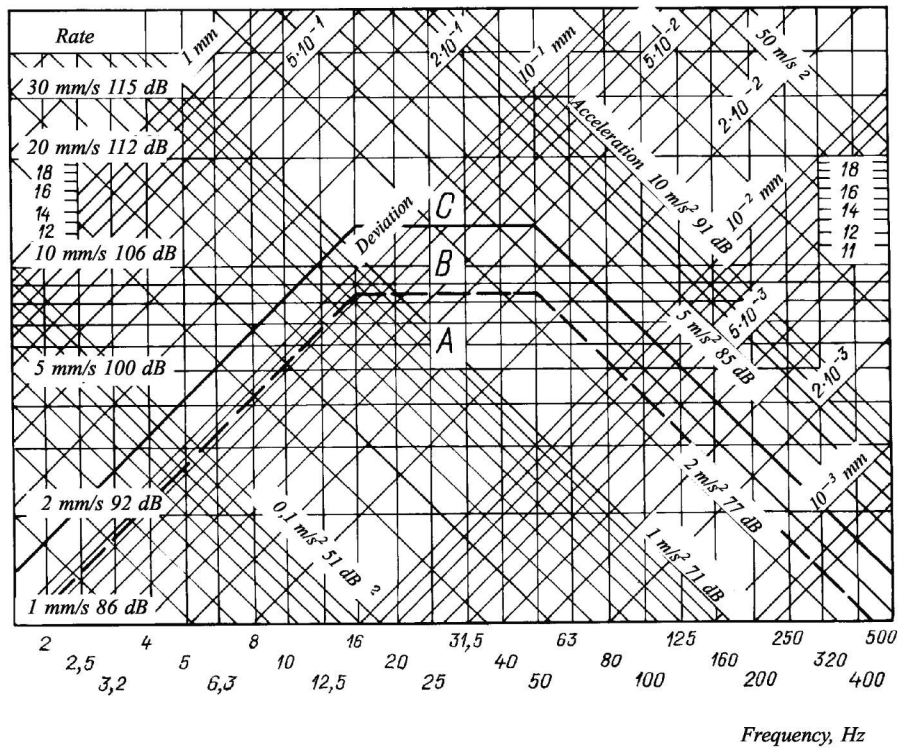

Fig. 9.5.3 Vibration standards for fans:

--- Upper limit of category A; — Upper limit of category B

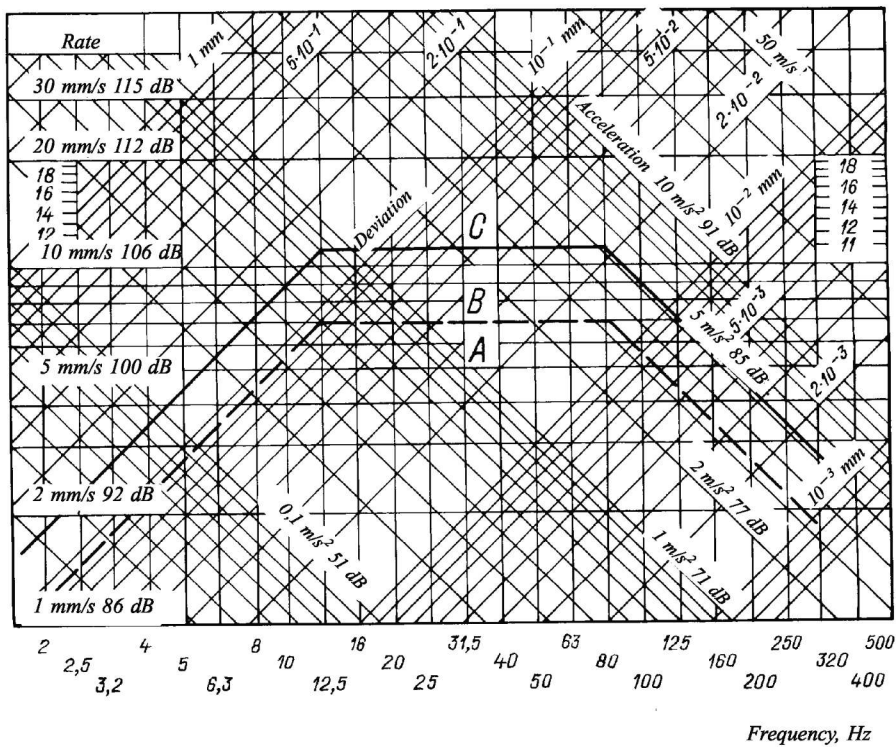

Fig. 9.5.4 Vibration standards for ICE-driven generators, shaft-generators, turbo-drives and turbo-generators of 1000 to 2000 kW capacity:

--- Upper limit of category A; — Upper limit of category B

**9.6 VIBRATION STANDARDS FOR PISTON AIR COMPRESSORS**

**9.6.1** Vibration of piston air compressors is assumed permissible for categories *A* and *B*, when the root-mean square values of vibration rate and vibration acceleration do not exceed the values stated in Table 9.4.1 and in Fig. 9.6.1. When the compressor is mounted on the shock-absorbers, the vibration standards shall be raised by 4 dB.

**9.7 VIBRATION STANDARDS FOR BOILERS AND HEAT EXCHANGERS**

**9.7.1** Vibration of boilers and heat exchangers is assumed permissible for categories *A* and *B*, when the root-mean square values of vibration rate and vibration acceleration do not exceed the values stated in Table 9.4.1 and in Fig. 9.7.1.

**9.7.2** Vibration standards for auxiliary machinery and equipments, not covered by 9.5 and 9.6, shall be chosen based on 9.7.1.

**9.8 VIBRATION STANDARDS FOR GEARED GAS TURBINES**

**9.8.1** Vibration of 250 to 25000 kW main geared gas turbines measured on the gas turbine supports and

reduction gear bearings is considered permissible, provided the root-mean square values of vibration rate and vibration acceleration do not exceed the values stated in Table 9.8.1 and shown in Fig. 9.8.1-1.

Points of vibration measuring are shown in Fig. 9.8.1-2.

**9.8.2** Vibration standards for auxiliary gas turbines of less than 250 kW power shall be subject to special consideration by the Register and shall be submitted by the gas turbine manufacturer.

**9.8.3** Vibration of gas-turbine-driven servo-machinery and devices shall not exceed the levels given in 9.8.1 and 9.8.2.

**9.8.4** The gas turbine manufacturer may deviate from the above standards, provided convincing data are available that the gas turbines are capable of operating under different vibration levels.

**9.9 VIBRATION STANDARDS FOR POWER-DRIVEN AZIMUTH THRUSTERS**

**9.9.1** Vibration standards are extended to cover azimuth thrusters ICE-driven up to 3,000 kW at rotation frequency of an input drive shaft of azimuth thruster to 2000 rev/min.

**9.9.2** The points and directions of vibration measuring are given in Fig. 9.9.2.

**9.9.3** Vibration of azimuth thrusters is considered admissible for the categories as follows *A* and *B*,

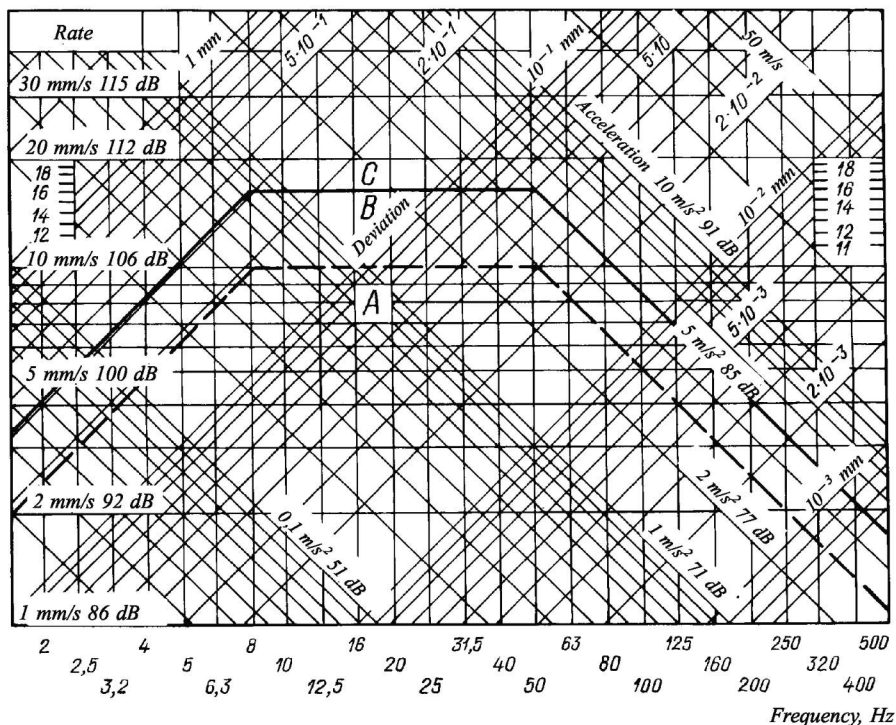

Fig. 9.6.1 Vibration standards for piston compressors:

--- Upper limit of category *A*;      ——— Upper limit of category *B*

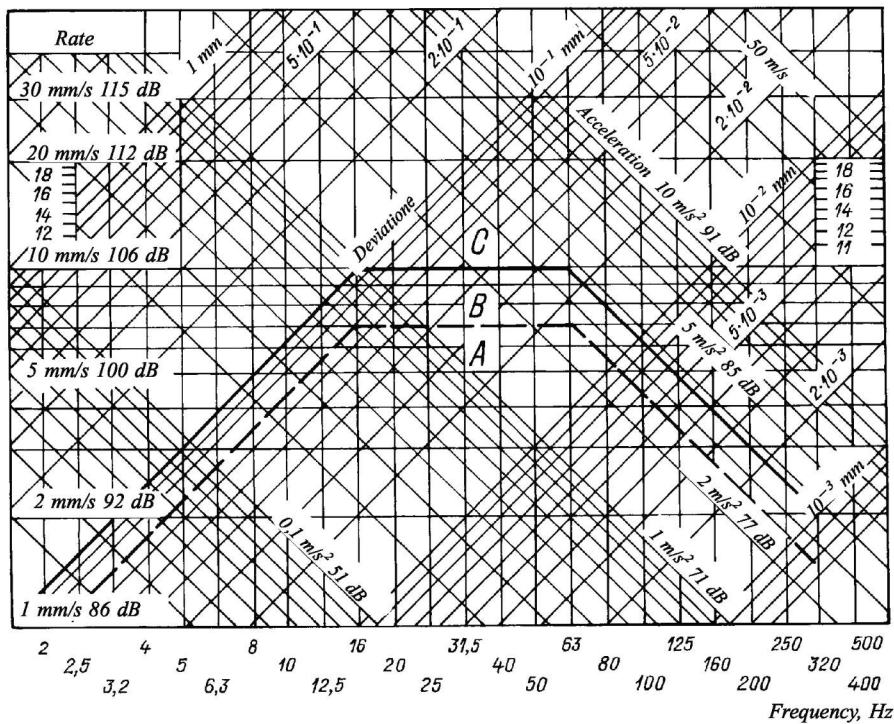

Fig. 9.7.1 Vibration standards for boilers, auxiliary machinery and equipment:

— — — — Upper limit of category A; ————— Upper limit of category B

Table 9.8.1

Vibration standards for geared gas turbines

Geometric mean frequencies of 1/3-octave bands, Hz	Permissible values of vibration rate				Geometric mean frequencies of 1/3-octave bands, Hz	Permissible values of vibration rate			
	category A		category B			category A		category B	
	mm/s	dB	mm/s	dB		mm/s	dB	mm/s	dB
1,6	1,6	90	2,9	96	125	8	104	16,5	110
2	1,8	91	3,5	97	160	8	104	16,5	110
2,5	2,2	93	4,3	98	200	8	104	16,5	110
3,2	2,7	95	5,3	100	250	8	104	16,5	110
4	3,2	96	7,0	103	320	8	104	16,5	110
5	4	98	9	105	400	8	104	16,5	110
6,3	5	100	11	107	500	8	104	16,5	110
8	6,7	103	13	108	640	6,5	102	12,5	108
10	8	104	16,5	110	800	4,8	100	10	106
12,5	8	104	16,5	110	1000	4	98	8	104
16	8	104	16,5	110	1280	3	96	7	103
20	8	104	16,5	110	1600	2,6	94	5	100
25	8	104	16,5	110	2000	2,1	92	3,9	98
31,5	8	104	16,5	110	2560	1,8	91	3	96
40	8	104	16,5	110	3200	1,5	90	2,4	95
50	8	104	16,5	110	4000	1	86	2	92
63	8	104	16,5	110	5120	—	—	1,7	91
80	8	104	16,5	110	6400	—	—	1,4	89
100	8	104	16,5	110	8000	—	—	1	86

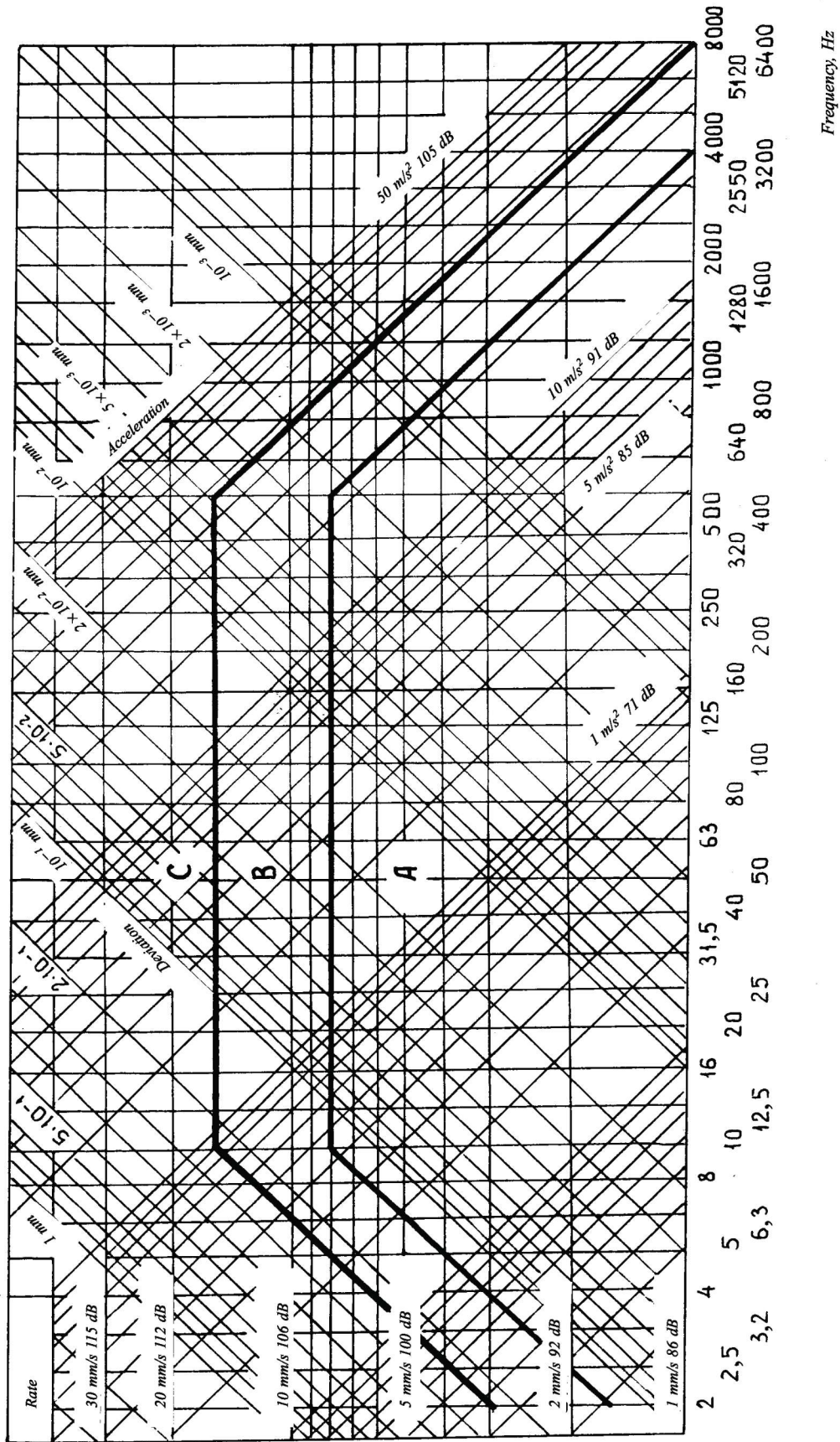

Fig. 9.8.1-1  
Vibration standards for geared gas turbines

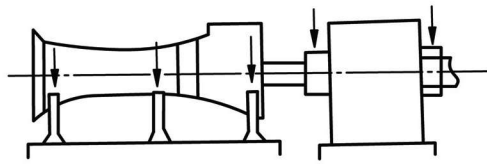

Fig. 9.8.1-2 Points of vibration measuring (the points and directions of vibration measurement are shown by arrows)

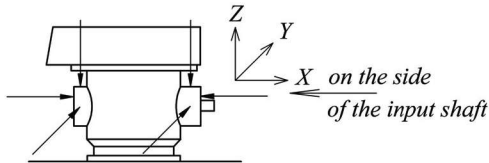

Fig. 9.9.2 Points of vibration measuring of azimuth thrusters

if the root-mean square values of vibration rate within the range of 10 — 1000 Hz determined by GOST ISO 10816-1-97 does not exceed the values in Table 9.9.3 and in Fig. 9.9.3.

**9.9.4** These standards may be waived like in the case of using on the drive shafts in shafting shall be subject to special consideration by the Register in each case.

Table 9.9.3

Vibration standards of azimuth thrusters

Relative rotation frequency of the driving shaft end	Admissible root-mean square values of vibration rate <sup>1</sup>			
	Category A		Category B	
	mm/s	dB	mm/s	dB
0.54	0.83	84	1.06	86
0.61	1.98	92	2.70	95
0.67	3.01	96	4.16	98
0.73	3.92	98	5.44	101
0.79	4.71	99	6.54	102
0.85	5.38	101	7.46	103
0.91	5.93	101	8.20	104
0.97	6.36	102	8.76	105
1.03	6.67	102	9.14	105
1.10	6.86	103	9.34	105

<sup>1</sup>The root-mean square values of vibration rate are determined in the frequency range of 10 — 1000 Hz in compliance with GOST ISO 10816-1-97/

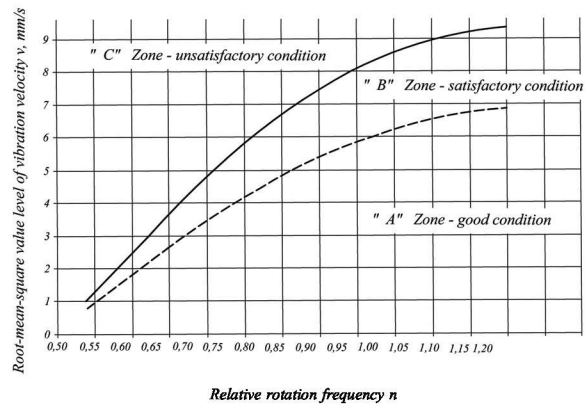

Fig. 9.9.3 Vibration standards of azimuth thrusters

## 10 MACHINERY TECHNICAL CONDITION MONITORING SYSTEMS

### 10.1 GENERAL

**10.1.1** The requirements of this Section apply to the machinery technical condition monitoring systems, which have been approved by the Register as the classification survey items on the basis of the Planned Maintenance Scheme (PMS) (refer to 2.7, Part II "Survey Procedure and Scope" of the Rules for the Classification Surveys of Ships in Service) and condition control (CC).

**10.1.2** Data of the machinery technical condition monitoring are intended for use:

by the Register Branch Office when carrying out surveys on the basis of PMS and CC;

by the ship crew to establish the terms for performing the machinery maintenance operations, i.e. providing maintenance on the "condition" basis;

by the Shipowner to assess the technical condition and to manage maintenance of ships, to schedule terms and scope of their repairs.

**10.1.3** The composition of the equipment of the technical condition monitoring system, controlled parameters and frequency of their measurements, standards of the control item technical condition shall be approved by the Register when the survey system on the basis of PMS and CC is implemented on board the ship.

**10.1.4** The organisational and normative and methodical principles of implementing technical condition monitoring systems on board the ship, submitting control data and assessment data of the technical condition of the control item are set out in 2.7, Part II "Survey Procedure and Scope" of the Rules for the Classification Surveys of Ships in Service.

### 10.2 CONTROL ITEMS AND PARAMETERS

**10.2.1** The technical condition monitoring system may cover the following equipment:

- main diesel engine, including turbocharger;
- main turbine;
- AMSS;
- reduction gear;
- shafting;
- stern tube gear;
- auxiliary diesel generators (turbogenerators);
- systems maintaining operation of the main diesel engine (compressed air, fuel oil, lubricating oil and cooling);
- steering gear.

**10.2.2** On agreement with the Register, the ship may be equipped with the technical condition monitoring systems exercising control over:

- the working process and wear of the cylinder and piston assembly of the main diesel engine;
- the working process of the turbine;
- the lubricating oil condition;
- the vibration condition of the machinery;
- the shock pulses of the roller bearings;
- the electric values of the electrical equipment.

**10.2.3** The conditions for acceptance of the technical condition monitoring results when carrying out surveys of the PMS and CC items are as follows:

the diagnostic parameters define the technical condition of the controlled item and are approved by the Register;

the limiting values of the diagnostic parameters have been determined on the basis of the requirements of the controlled item manufacturers and/or the Register;

the parameters used for the technical condition prediction shall be brought to standard conditions. The measured parameter values are brought to the standard conditions in accordance with 2.2.7, Part IX "Machinery";

the results of measurements, trend analysis and prediction of parameters shall be kept in a form accessible for the Surveyor: in the tabular form, in the form of graphs on paper media or, preferably, on the PC media;

the frequency of the diagnostic parameter measurements shall provide reliability of determination of the control item technical condition;

the measuring instruments used in the technical condition monitoring systems shall have appropriate documents on verification by a competent authority.

### 10.3 GENERAL REQUIREMENTS FOR TECHNICAL CONDITION MONITORING SYSTEMS

**10.3.1** The technical condition monitoring systems may be constructed on the basis of built-in (fixed) condition monitoring systems, portable control facilities or may combine both.

**10.3.2** The built-in technical condition monitoring systems of the main engines, as a rule, shall be integrated structurally with the centralized monitoring systems and be capable of using the data obtained from the sensors of the centralized control system. Technical condition monitoring system integrated with the

centralized control system shall not affect the centralized monitoring functions.

**10.3.3** The technical condition monitoring system integrated with the centralized control system shall incorporate the technical condition diagnosis functions with the aim to perform the maintenance and repair of the control item on the actual condition basis.

**10.3.4** The built-in monitoring systems and their elements shall meet the requirements imposed on the ship automation systems (refer to Section 2, Part XV "Automation").

The built-in monitoring systems installed on board the ships under construction or while in service shall be approved by the Register.

The built-in monitoring systems installed on board the ships are subject to the technical supervision with respect to:

- check for functioning;
- selection of cable cross-section;
- protection, insulation and earthing means;
- zero influence exerted by these systems on the operation of the equipment related to the items of the technical supervision of the Register.

Failures in the operation of the built-in monitoring system shall not adversely affect the operation of the equipment.

**10.3.5** The portable control facilities and procedures for their application may be provided on board the ships under construction (or in service) after agreement with the Register. The basis for the agreement is the attestation thereof and conclusion (on the basis of examination of the necessary materials and/or carrying out of tests) of a competent organization regarding techniques and means for diagnosis of the ship facilities.

**10.3.6** The technical condition monitoring system shall provide for recording the diagnostic parameter values, their trend analysis, prediction of the control item technical condition. The condition prediction is performed on the basis of the previous history of diagnostic parameters with sufficient number of their measurements.

**10.3.7** The requirements for computers used in the technical condition monitoring systems are similar to the requirements of Section 7, Part XV "Automation".

**10.3.8** The basic values of the diagnostic parameters used as initial (reference) data during the technical condition monitoring shall be obtained under the specific conditions of draught and the ship speed (at sea) and under operating conditions of the main engines and auxiliaries.

The basic data may be obtained on acceptance trials or on maiden voyage for a newbuilding or on another operational voyage under steady operating modes of the control items agreed with the Register.

#### 10.4 TECHNICAL DOCUMENTATION

**10.4.1** The following types of documentation on the technical condition monitoring system shall be submitted to the Register for review and approval:

- .1 functional description with indication of the technical data and operating conditions (no approval stamp is affixed);
- .2 methodological guidelines (instructions) for making measurements and control data processing (no approval stamp is affixed);
- .3 test program for the built-in monitoring systems.

#### 10.5 REQUIREMENTS FOR WORKING LUBRICATING OIL PARAMETERS

**10.5.1** The requirements for the controlled parameters of working lubricating oils shall be consistent with the type of equipment to be surveyed. Oil grades and methods of oil sampling for analysis shall be indicated for each machinery. The oil sampling location shall be clearly described.

**10.5.2** The range of the characteristics and rejected parameter values of the oils to be analyzed are established by a developer of the monitoring system and agreed with the Register.

**10.5.3** The oil sample shall be analyzed by a recognized shore-based laboratory. On board the ships the ship rapid analysis attested by a competent organisation shall be used (refer to 10.3.5).

**10.5.4** The results of the oil analysis are submitted according to 10.2.3.

#### 10.6 REQUIREMENTS FOR CONTROL OF THE DIESEL ENGINE WORKING PROCESS PARAMETERS

**10.6.1** The requirements apply to the equipment for measuring pressure in the engine cylinder and fuel supply parameters.

**10.6.2** To process the measurement results of the working process parameters, use is also made of the parameters measured in the alarm system. In this case, interference shall not be introduced into the operation of the alarm system.

**10.6.3** The Register shall be given specifications of sensors, measuring equipment and measurement results processing program (including list of calculated parameters and method of presentation thereof).

**10.6.4** The electronic unit used for measurement of the working process parameters shall have dynamic characteristics providing for the measurement of the maximum gas pressure in cylinder.

**10.6.5** Measurement of the pressure in cylinder and fuel supply parameters with the use of the sensors presented is allowed to be made not on all cylinders simultaneously, but for all that the steady operating conditions of the diesel engine shall be maintained.

**10.6.6** The equipment for measurement, processing and presentation of the cylinder pressure curve (indicator diagram) and the fuel supply characteristics shall provide for the analysis thereof with a resolution of not less than one degree of the crankshaft rotation.

**10.6.7** The indicator diagram processing program shall calculate for each cylinder:

- mean indicated pressure;
- cylinder indicated power;
- maximum cylinder combustion pressure;
- maximum compression pressure;
- pressure on compression line at point 12° before the top dead centre (TDC);
- pressure on expansion line at point 36° after the TDC;
- the crankshaft rotation angle corresponding to the maximum combustion pressure;
- ignition advance angle.

**10.6.8** The fuel supply parameters processing program shall determine:

- fuel injection beginning;
- fuel injection time angle;
- maximum fuel pressure.

**10.6.9** The processing program shall provide for comparison of the loading in cylinders.

Permissible deviations of the working process parameters from the average over the cylinders:

- mean indicated pressure — not more than  $\pm 2,5$  per cent;
- maximum combustion pressure — not more than  $\pm 3,5$  per cent;
- compression end pressure —  $\pm 2,5$  per cent.

The cited values of the combustion pressure in any cylinder shall not be less than 85 per cent of the value obtained on basic tests.

The results of basic tests are considered to mean the results of the acceptance tests of the diesel engine on board or special tests on operational voyage (refer to 10.3.8).

**10.6.10** The measurement data shall be submitted according to 10.2.3.

#### 10.7 REQUIREMENTS FOR CONTROL OF WEAR PARAMETERS OF THE ENGINE CYLINDER AND PISTON ASSEMBLY

**10.7.1** The parameter, which defines the engine cylinder and piston assembly condition (its wear), is the tightness of the combustion chamber.

**10.7.2** The tightness of the combustion chamber is measured by a special instrument: pneumoindica-

tor, which is a flow-metering device set at a particular cylinder diameter.

**10.7.3** The methods for determination of the cylinder tightness and the standards for the cylinder and piston assembly condition shall be presented by the system developer.

**10.7.4** The results shall be submitted according to 10.2.3.

#### 10.8 REQUIREMENTS FOR CONTROL OF VIBRATION PARAMETERS

**10.8.1** The items of vibration condition monitoring on board the ship are machinery of rotary type listed in 10.2.1 as well as piston compressors.

**10.8.2** For the purpose of the machinery vibration condition monitoring, use shall be made of the following equipment, which provides for the measurement and processing of the vibration parameters: root-mean-square values of vibration rate or vibration acceleration in 1/3-octave band and in octave band, and the data analysis in temporal area:

- vibrometers-analyzers;
- vibration diagnosis systems performing measurement, processing, storage and spectrum analysis of the vibration parameters.

**10.8.3** The basic requirements for the equipment used in the vibration condition monitoring system:

- the housing of the vibrometer-analyzer shall correspond to the IP54 protection type (refer to 2.4.4.2, Part XI "Electrical Equipment");
- frequency range — not less than 4 to 16000 Hz;
- dynamic range — not less than 70 dB.

Special requirements for the vibration diagnosis systems:

- the possibility of operating according to a process chart, which ensures performance of at least one complete measurement of the vibration parameters on all the monitoring system objects;

- the possibility of transferring data to computer.

**10.8.4** The composition of the vibration condition monitoring equipment and organization of the performance thereof shall be agreed upon with the Register when the PMS and CC based survey system is being implemented on board the ship.

**10.8.5** When performing the vibration condition monitoring, consideration shall be given to the provisions of 18.7, Part V "Technical Supervision during Construction of Ships" of the Rules for Technical Supervision during Construction of Ships and Manufacture of Materials and Products for Ships.

**10.8.6** The requirements for the installation and attachment of the vibration pickup on the controlled item shall be provided. The preference shall be given to attachment of the pickup by a pin (screw). To realize such attachment method, pins shall be fitted

beforehand at all measurement points. The vibration pickups may be installed on a magnet. Where the vibration pickups cannot be installed using a pin or magnet, manual vibration pickups may be used.

**10.8.7** For each machinery, points and directions for measuring vibration parameters shall be indicated. The manufacturers' recommendations shall be used. Where no such recommendations are available, type lay-out diagrams of the machinery vibration measurement points shall be taken as a guide (refer to 9.2.5).

For the vibration condition monitoring, measurement may be restricted to one or two directions on one most loaded machinery bearing.

*Note.* For units consisting of a machinery and its driving unit (pump and electric motor, fan and electric motor), measurements are made on one machinery bearing and one motor bearing on the coupling side. When exercising control of the separator vibration condition, measurements shall be made in two radial directions on both motor bearings and in three directions on the separator bowl bearing.

**10.8.8** Standardization of the condition on the basis of the controlled parameter vibration levels shall be displayed in the documentation of the technical condition monitoring system submitted to the Register for review (refer to 10.4.1). It is necessary to use the recommendations of the control item manufacturer or to be guided by the Register standards (refer to Section 9).

**10.8.9** The results shall be submitted according to 10.2.3.

#### 10.9 REQUIREMENTS FOR CONTROL OF THE SHOCK PULSE

**10.9.1** The condition of the roller bearings is assessed by a shock pulse method. The controlled machinery manufacturer, developer or supplier of the technical condition monitoring system may propose another method of roller bearing condition assessment. In this case, the proposed method shall be approved by the Register.

**10.9.2** For the bearing condition control by shock pulse method, special instruments are used: shock pulse meters and/or roller bearing condition indicators, which shall meet the following basic requirements:

- .1 range of controlled bearings:  
internal diameter — 50 to 1000 mm;  
speed — 10 to 30000 min<sup>-1</sup>;  
dynamic range — not less than 90 dB;

- .2 as regards dust- and water tightness, the instrument housing shall correspond to IP54 protection type (refer to 2.4.4.2, Part XI "Electrical Equipment");

- .3 instrument for control of the roller bearing condition may be combined with the vibrometer (refer to 10.8.2).

**10.9.3** The instrument for control of the roller bearing condition shall be fitted with a built-in calibrator to verify precision of readings.

**10.9.4** The measurement methods shall make it possible to separate the values of shock pulses arising due to the roller bearing against the background of the signals from other sources. The methods shall establish positions for other measurements to be made on the bearing housing on the basis of the maximum shock pulse value or contemplate special devices — measuring bolts, where there is no direct access to the bearing housing.

**110.9.5** The shock pulse standards defining lubrication condition and roller bearing damages shall be presented by the manufacturer of the technical condition monitoring system.

**10.9.6** The results of control shall be submitted according to 10.2.3.

#### 10.10 REQUIREMENTS FOR THE TREND ANALYSIS OF THE DIAGNOSTIC PARAMETERS AND FOR THE TECHNICAL CONDITION PREDICTION

**10.10.1** The processing program for the diagnostic parameters measured by the built-in condition monitoring systems shall contemplate a trend analysis and prediction of the parameter changing. The trend analysis of the diagnostic parameters measured by the portable control facilities shall be made after each last measurement.

**10.10.2** The parameter trend is based on the measurements made during the period between special surveys with a frequency not less than 4 to 5 measurements at approximately equal time intervals.

**10.10.3** The controlled item condition is predicted for the forthcoming time period between annual surveys. The prediction is made either on the basis of the past history of the parameters defining condition or on the basis of the known rate of the parameter change. On completion of the measurement, the prediction shall be adjusted.

**10.10.4** Based on the prediction results, the frequency of the condition control may be changed. If the prediction results indicates that the limiting values of the controlled parameters can be attained, the intervals between the measurements shall be reduced, the causes of the condition degradation established and the maintenance planned.

**10.10.5** If the item condition is described by the several independent parameters, prediction shall be made for each parameter. In this case, maintenance becomes necessary when any of the parameters to be predicted reaches the limiting value.

**10.10.6** The monitoring system shall be accompanied by the prediction procedure. Along with that, the Register shall be given data confirming reliability of the procedure.

## 11 QUALITATIVE FAILURE ANALYSIS FOR PROPULSION AND STEERING ON PASSENGER SHIPS

### 11.1 SCOPE OF APPLICATION

**11.1.1** The requirements of the present Section refer to the qualitative failure analysis for propulsion and steering for new passenger ships, including those having a length of 120 m or more or having three or more main vertical zones (refer to 2.2, Part VI "Fire Protection") in compliance with the revised SOLAS Chapter II-2, Regulation 21 (IMO resolution MSC.216(82), Annex 3).

**11.1.2** For ships having at least two independent means of propulsion and steering to comply with SOLAS requirements for a safe return to port, the following shall be provided:

**.1** knowledge of the effects of failure in all the equipment and systems due to fire in any space, or flooding of any watertight compartment that could affect the availability of the propulsion and steering;

**.2** solutions to ensure the availability of propulsion and steering upon such failures specified in 11.1.2.1.

**11.1.3** Ships not required to satisfy the safe return to port concept will require the analysis of failure in single equipment and fire in any space to provide knowledge and possible solutions for enhancing availability of propulsion and steering.

### 11.2 SYSTEMS TO BE CONSIDERED

**11.2.1** The qualitative failure analysis shall consider the propulsion and steering equipment and all its associated systems which might impair the availability of propulsion and steering.

**11.2.2** The qualitative failure analysis shall include:

**.1** propulsion and electrical power prime movers (diesel engines, electric motors);

**.2** power transmission systems (shafting, bearings, power converters, transformers, slip ring systems);

**.3** steering gear (rudder actuator or equivalent for azimuthing propulsor, rudder stock with bearings and seals, rudder, power unit and control gear, local control systems and indicators, remote control systems and indicators, communication equipment);

**.4** propulsors (propeller, azimuthing thruster, water jet);

**.5** main power supply systems (electrical generators and distribution systems, cable runs, hydraulic, pneumatic);

**.6** essential auxiliary systems (compressed air, oil fuel, lubricating oil, cooling water, ventilation, fuel storage and supply systems);

**.7** control and monitoring systems (electrical auxiliary circuits, power supplies, protective safety systems, power management systems, automation and control systems);

**.8** support systems (lighting, ventilation).

To consider the effects of fire or flooding in a single compartment, the analysis shall address the location and layout of equipment and systems.

### 11.3 FAILURE CRITERIA

**11.3.1** Failures are deviations from normal operating conditions such as loss or malfunction of a component or system such that it cannot perform an intended or required function.

**11.3.2** The qualitative failure analysis shall be based on single failure criteria (not two independent failures occurring simultaneously).

**11.3.3** Where a single failure cause results in failure of more than one component in a system (common cause failure), all the resulting failures shall be considered together.

**11.3.4** Where the occurrence of a failure leads directly to further failures, all those failures shall be considered together.

### 11.4 VERIFICATION OF SOLUTIONS

**11.4.1** The shipyard shall submit a report to the Register that identifies how the objectives have been addressed. The report shall include the following information:

**.1** the standards used for analysis of the design;

**.2** the objectives of the analysis;

**.3** any assumptions made in the analysis;

**.4** the equipment, system or sub-system, mode of operation of the equipment;

**.5** probable failure modes and acceptable deviations from the intended or required function;

.6 evaluation of the local effects (e.g. fuel injection failure) and the effects on the system as a whole (e.g. loss of propulsion power) of each failure mode as applicable;

.7 trials and testing necessary to prove conclusions.

*Note.* All stakeholders (the Register, shipowners, shipyard and manufacturers) shall as far as possible be involved in the development of the report.

**11.4.2** The report shall be submitted prior to approval of detail design plans. The report may be submitted in two parts:

.1 a preliminary analysis as soon as the initial arrangements of different compartments and propulsion plant are known which can form the basis of discussion. This shall include a structured assessment of all essential systems supporting the propulsion plant after a failure in equipment, fire or flooding in any compartment casualty;

.2 a final report detailing the final design with a detailed assessment of any critical system identified in the preliminary report.

**11.4.3** Verification of the report findings shall be agreed between the Register and the shipyard.

## APPENDIX 1

## LIST OF MINIMUM RECOMMENDED SPARE PARTS

Tables 1 to 4 contain the list of recommended spare parts to the equipment supervised by the Register and essential to the propulsion and safety of the ship.

The spare parts shall be properly secured in easily accessible places, marked and efficiently protected against corrosion.

Table 1

List of minimum recommended spare parts for main internal combustion engines of ships for unrestricted service

Nos.	Item	Spare part	Number recommended
1	Main bearings	Main bearings or shells for one bearing of each size and type fitted, complete with shims, bolts and nuts	1
2	Main thrust block	Pads for one face of Michell type thrust block, or	1 set
		Complete white metal thrust shoe of solid ring type, or	1
		Inner and outer race with rollers, where roller thrust bearings are fitted	1
3	Cylinder liner	Cylinder liner, complete with joint rings and gaskets	1
4	Cylinder cover	Cylinder cover, complete with valves, joint rings and gaskets	1
		Cylinder cover bolts and nuts, for one cylinder	½ set
5	Cylinder valves	Exhaust valves, complete with casings, seats, springs and other fittings for one cylinder	2 sets
		Air inlet valves, complete with casings, seats, springs and other fittings for one cylinder	1 set
		Starting air valve, complete with casting, seat springs and other fittings	1
		Cylinder overpressure sentinel valve, complete	1
		Fuel valves of each size and type fitted, complete with all fittings, for one engine	1 set <sup>1</sup>
6	Connecting rod bearings	Bottom end bearings or shells of each size and type fitted, complete with shims, bolts and nuts, for one cylinder	1 set
		Top end bearings or shells of each size and type fitted, complete with shims, bolts and nuts, for one cylinder	1 set
7	Pistons	Crosshead type internal combustion engine; piston of each type fitted, complete with piston rod, stuffing box, skirt, rings, studs and nuts	1
		Trunk piston type internal combustion engine: piston of each type fitted, complete with skirt, rings, studs, nuts, gudgeon pin and connecting rod	1
8	Piston rings	Piston rings, for one cylinder	1 set
9	Piston cooling	Telescopic cooling pipes and fittings or their equivalent, for one cylinder unit	1 set
10	Cylinder lubricators	Lubricator, complete, of the largest size, with its chain drive or gear wheels, or equivalent spare part kit	1
11	Fuel injection pumps	Fuel pump complete or, when replacement at sea is practicable, a complete set of working parts for one pump (plunger, sleeve, valves, springs, etc.), or equivalent high pressure fuel pump	1
12	Fuel injection piping	High pressure double wall fuel pipe of each size and shape fitted, complete with couplings	1
13	Scavenge blower (including turbo chargers)	Rotors, rotor shafts, bearings, nozzle rings and gear wheels or equivalent working parts if other types	1 set <sup>2</sup>
14	Scavenging system	Suction and delivery valves for one pump of each type fitted	1 set
15	Reduction and/or reverse gear	Complete bearing bush, of each size fitted in the gear case assembly	1 set
		Roller or ball race, of each size fitted in the gear case assembly	1 set

Table 1 — continued.

<p><sup>1</sup> (a) Engines with one or two fuel valves per cylinder: one set of fuel valves, complete.  (b) Engines with three or more fuel valves per cylinder: two fuel valves complete per cylinder, and a sufficient number of valve parts, excluding the body, to form, with those fitted in the complete valves, a full engine set.</p> <p><sup>2</sup> The spare parts may be omitted where it has been demonstrated, at the Builder's test bench for one engine of the type concerned, that the engine can be manoeuvred satisfactorily with one blower out of action.  The requisite blanking and blocking arrangements for running with one blower out of action are to be available on board (refer to 2.1.7, Part VII "Machinery Installations").</p> <p><b>Notes:</b></p> <ol style="list-style-type: none"> <li>1. The availability of other spare parts, such as gears and chains for camshaft drive, should be specially considered and decided upon by the owner.</li> <li>2. It is assumed that the new crew has on board the necessary tools and equipment.</li> <li>3. When the recommended spares are utilized, it is recommended that new spares are supplied as soon as possible.</li> <li>4. In case of multi-engine installations, the minimum recommended spares are only necessary for one engine.</li> <li>5. For electronically controlled engines spare and dual-fuel internal combustion engines parts as recommended by the engine designer/manufacturer</li> </ol>
--

Table 2

List of minimum recommended spare parts for each part of auxiliary internal combustion engine driving electric generators for essential services on board ships for unrestricted service

Nos.	Item	Spare part	Number recommended
1	Main bearings	Main bearings or shells for one bearing of each size and type fitted, complete with shims, bolts and nuts	1
2	Cylinder valves	Exhaust valves, complete with casings, seats, springs and other fittings for one cylinder	2 sets
		Air inlet valves, complete with casings, seats, springs and other fittings for one cylinder	1 set
		Starting air valve, complete with casing, seat springs and other fittings	1
		Cylinder overpressure sentinel valve, complete	1
		Fuel valves of each size and type fitted, complete with all fittings, for one engine	½ set
3	Connecting rod set bearings	Bottom end bearings or shells of each size and type fitted, complete with shims, bolts and nuts, for one cylinder	1 set
		Trunk piston internal combustion engine type: gudgeon pin with bush for one cylinder	1 set
4	Piston rings	Piston rings, for one cylinder	1 set
5	Piston cooling	Telescopic cooling pipes and fittings or their equivalent, for one cylinder	1 set
6	Fuel injection pumps	High pressure double wall fuel pipe of each size and shape fitted, complete with couplings	1
7	Fuel injection piping	High pressure double wall fuel pipe of each size and shape fitted, complete with couplings	1
8	Gaskets and Packings	Special gaskets and packings of each size and type fitted, for cylinder covers and cylinder liners for one cylinder	1 set
<p><b>Notes:</b></p> <ol style="list-style-type: none"> <li>1. The availability of other spare parts should be specially considered and decided upon by the shipowner.</li> <li>2. It is assumed that the crew has on board the necessary tools and equipment.</li> <li>3. When the recommended spares are utilized, it is recommended that new spares are supplied as soon as possible.</li> <li>4. Where the number of generators of adequate capacity fitted for essential services exceeds the required number, spare parts may be omitted.</li> <li>5. For electronically controlled engines and dual-fuel internal combustion engines spare parts as recommended by the engine designer/manufacturer.</li> </ol>			

Table 3

**List of minimum recommended spare parts for each steam turbines driving electric generators for essential services of ships for unrestricted service**

Nos.	Item	Spare part	Number recommended
1	Turbine shaft	Carbon sealing rings, where fitted, with springs, for each size and sealing rings type of gland, for one turbine	1 set
2	Oil filters	Strainer baskets or inserts, for filters of special design, of each type and size	1 set
<b>Notes:</b> 1. The availability of other spare parts shall be specially considered and decided upon by the Shipowner. 2. It is assumed that the crew has on board the necessary tools and equipment. 3. When the recommended spares are utilized, it is recommended that new spares are supplied as soon as possible. 4. Where the number of generators of adequate capacity fitted for essential services exceeds the required number, spare parts may be omitted.			

Table 4

**List of minimum recommended spare parts for main steam turbines of ships for unrestricted service**

Nos.	Item	Spare part	Number recommended
1	Turbine shaft	Carbon sealing rings, where fitted, with springs for each size sealing rings and type of gland	1 set
2	Oil filters	Strainer baskets or inserts for filters of special design, of each type and size	1 set
<b>Notes:</b> 1. The availability of other spare parts should be specially considered and decided upon by the Shipowner. 2. It is assumed that the crew has on board the necessary tools and equipment. 3. When the recommended spares are utilized, it is recommended that new spares are supplied as soon as possible. 4. In the case of multi-engine installations, the minimum recommended spare parts are only necessary for one engine.			

Table 5

**List of minimum recommended spare parts for essential auxiliary machinery of ships for unrestricted service**

Nos.	Item	Spare part	Number recommended
<b>Pumps</b>			
1	Piston pumps	Valve with seats and springs, each size fitted	1 set
		Piston rings, each type and size for one piston	1 set
2	Centrifugal pumps	Bearing of each type and size	1
		Rotor sealings of each type and size	1
3	Gear type pumps	Bearings of each type and size	1
		Rotor sealings of each type and size	1
<b>Notes:</b> 1. When a sufficiently rated standby pump is available, the spare parts may be dispensed with. 2. It is recommended that where, for maintenance or repair work of the pumps, special tools or equipment shall be used, these are available on board. 3. When the recommended spares are utilized, it is recommended that new spares are supplied as soon as possible.			
<b>Compressors</b>			
1	Valves	Suction and delivery valves complete of each size fitted in one unit	½ set
2	Pistons	Piston rings of each type and size fitted for one piston	1 set
<b>Notes:</b> 1. It is recommended that where, for maintenance or repair work of the compressors, special tools or equipment shall be used, these are available on board. 2. When the recommended spares are utilized, it is recommended that new spares are supplied as soon as possible.			

## APPENDIX 2

## SPECIAL APPROVAL OF ALLOY STEEL FOR INTERMEDIATE SHAFT MATERIAL

### 1 APPLICATION

#### 1.1 General.

**1.1.1** The requirements apply to the approval of alloy steel which has a minimum specified tensile strength greater than 800 MPa, but less than 950 MPa intended for use as intermediate shaft material.

**1.1.2** The Section contains the main data on the steel fatigue evaluation by means of torsional fatigue testing. The purpose of the torsional fatigue test shall be meeting the requirements to the torsional fatigue to be equal to the intermediate shaft material, specified in the corresponding Sections of the Rules given by the formulae. The torsional fatigue strength of said material is to be equal to or greater than the permissible torsional vibration stress  $\tau_C$  given by Formulae 8.3.1.

**1.1.3** The chemical composition for forgings shall meet the minimum requirements specified in Table 3.7.2.3-2, Part XIII "Materials", considering the content of sulphur, phosphorus and oxygen. The chemical composition, structures and mechanical properties shall meet the minimum requirements of Part XIII "Materials" and shall be submitted to the Register for consideration.

### 2 CARRYING OUT OF TESTS

**2.1** The tests shall be carried out with notched and unnotched specimens respectively. For calculation of the stress concentration factor of the notched specimen, fatigue strength reduction factor  $\beta$  shall be evaluated in consideration of the severest torsional stress concentration in the design criteria. Mean surface roughness shall be  $<0,2\mu\text{m } R_a$  with the absence of localized machining marks verified by visual examination at low magnification ( $\times 20$ ) as required by Section 8.4 of ISO 1352. Test procedures shall be in accordance with Section 10 of ISO 1352.

**2.2** Test conditions shall be in accordance with Table 1.

Table 1

Loading type	Torsion
Stress ratio	$R = -1$
Load waveform	Constant — amplitude sinusoidal
Evaluation	S-N curve
Number of cycles for test terminal	$1 \times 10^7$
Specimens	Notched and unnotched

**2.3** The steels shall have a degree of cleanliness as shown in Table 2 when tested according to ISO 4967 method A. Representative samples shall be obtained from each heat of forged or rolled products. The samples shall be subject to ultrasonic testing required by 3.7,7.2 Part XIII "Materials" prior to acceptance.

Table 2

A	Fine	1
	Thick	1
B	Fine	1,5
	Thick	1
C	Fine	1
	Thick	1
D	Fine	1
	Thick	1
DS	—	1

### 3 ACCEPTANCE CRITERIA

Total stresses shall be equal to or greater than the values given by the following formulae:

For measured high-cycle torsional fatigue strength  $\tau_{C1}$

$$\tau_{C1} \geq \tau_{C,\lambda=0} \frac{\sigma_B + 160}{6} C_K C_D \quad (1-1)$$

For low-cycle torsional fatigue strength  $\tau_{C2}$ :

$$\tau_{C2} \geq 1,7 \frac{1}{\sqrt{C_K}} \tau_{C1}, \quad (1-2)$$

where:  $\tau_C$  = permissible amplitude of stress in MPa in the sample due to torsional vibration for continuous operation (refer to 8.3.1);

$\sigma_B$  = specified minimum tensile strength in MPa of the shaft material;

$C_K$  = factor for the particular shaft design features; when selecting stress concentration factor, scf, (for calculating  $C_K$  for unnotched specimen, scf = 1 (refer to Table 8.3.1));

$C_D$  = size factor (refer to 8.2.1).



**LIST OF CIRCULAR LETTERS AMENDING/SUPPLEMENTING NORMATIVE DOCUMENT**

(Normative document No. and title)

Item No.	Circular letter No., date of approval	List of amended and supplemented paras



# RUSSIAN MARITIME REGISTER OF SHIPPING

CIRCULAR LETTER

No. 313-07-1088c

dated 29.12.2017

Re:

amendments to the Rules for the Classification and Construction of Sea-Going Ships, 2018,  
ND No. 2-020101-104-E in connection with deletion of IACS Unified Interpretation (UI) SC242 (Rev.1 Apr 2016)

Item of technical supervision:

Ships under construction

Implementation from 01.01.2018

Valid: till ----

Validity period extended till ----

~~Cancels / Amends / Supplements~~ Circular Letter No. ---- dated ----

Number of pages: 1+2

Appendices: text of amendments to Part VII "Machinery Installations" of the Rules for the Classification and Construction of Sea-Going Ships, 2018, ND No. 2-020101-104-E

Director General

K.G. Palnikov

Amends Rules for the Classification and Construction of Sea-Going Ships, 2018,  
ND No. 2-020101-104-E

We hereby inform that in connection with deletion of IACS UI SC242 (Rev.1 Apr 2016) on 20.12.2017 and reinstatement of IACS UI SC242 (Corr.1 Aug 2011) reinstatement, Part VII "Machinery Installations" of the Rules for the Classification and Construction of Sea-Going Ships, 2018, ND No. 2-020101-104-E shall be amended as specified in the Appendix to the Circular Letter.

The original IACS UI SC242 (Corr.1 Aug 2011 reinstated from 21 Dec 2017) in English is posted on the RS internal website in the Section "RS External Normative Documents/02 IACS Documents/ND No. 1-0221-242-E."

It is necessary to do the following:

1. Apply the provisions of the Circular Letter during review and approval of the ships' technical documentation.
2. Bring the content of the Circular Letter to the notice of the RS surveyors, interested organizations and persons in the area of the RS Branch Offices' activity.

Person in charge: A.V. Serov

Department 313

(812) 3123985

"Thesis" System: 17-345728

**RULES FOR THE CLASSIFICATION AND CONSTRUCTION OF SEA-GOING SHIPS,  
2018, ND No. 2-020101-104-E**

**PART VII. MACHINERY INSTALLATIONS**

**7.2 CONSTRUCTION REQUIREMENTS**

**Para 7.2.3** shall be amended to read:

"**7.2.3** In a ship fitted with multiple steering systems, such as but not limited to steerable propellers or water jet propulsion systems, each of the steering systems shall be equipped with its own independent steering gear to meet the requirements of 2.9.1, Part III "Equipment, Arrangements and Outfit" and 6.2.1.1, Part IX "Machinery"."

**Para 7.2.5** shall be amended to read:

"**7.2.5** In a ship fitted with multiple steering systems, such as but not limited to steerable propellers or water jet propulsion systems, an auxiliary steering gear need not be fitted, provided that:

.1 in a passenger ship, each of the steering systems is fitted with two or more identical power units, capable of satisfying the requirements of 7.2.4.2 while any one of the power units is out of operation;

.2 in a cargo ship, each of the steering systems is fitted with one or more identical power units, capable of satisfying the requirements of 7.2.4.2 while operating with all power units;

.3 each of the steering systems is arranged so that after a single failure in its piping or in one of the power units, ship steering capability (but not individual steering system operation) can be maintained or speedily regained (e.g. by the possibility of positioning the failed steering system in a neutral position in an emergency, if needed)."

**Para 7.2.7** shall be amended to read:

"**7.2.7** The ability of the machinery to reverse the direction of thrust in sufficient time, and so to bring the ship to rest within a reasonable distance from maximum ahead service speed, shall be demonstrated and recorded.

The steerable propeller designed for reversing the thrust by turning the unit shall provide an acceptable reversing time depending on the purpose of the ship. The time required for turning the unit through 180° shall not then exceed 20 s for the units with a propeller of 2 m and less in diameter and shall not exceed 30 s for the units with a propeller of more than 2 m in diameter.

The stopping times, ship headings and distances recorded on trials, together with the results of trials to determine the ability of ships having multiple propulsion/steering arrangements to navigate and manoeuvre with one or more of these devices inoperative, shall be available on board for the use of the master or designated personnel."

**Para 7.2.14** shall be supplemented with the following sentence:

"Refer also to the Note to 7.2.4."



# RUSSIAN MARITIME REGISTER OF SHIPPING

---

**CIRCULAR LETTER**

**No. 313-08-1163c**

dated 24.09.2018

---

Re:

amendments to the Rules for the Classification and Construction of Sea-Going Ships, 2018, ND No. 2-020101-104-E

---

Item(s) of supervision:

ships under construction

---

Implementation:

**from the date of publication**

Valid till:

-----

Validity period extended till: ----

---

Cancels / amends / adds Circular Letter No. ----

dated ----

---

Number of pages:

1 + 4

---

Appendix(ces):

amendments to Parts VI "Fire Protection", VII "Machinery Installations", IX "Machinery", X "Boilers, Heat Exchanges and Pressure Vessels" and XVII "Distinguishing Marks and Descriptive Notations in the Class Notation Specifying Structural and Operational Particulars of Ships" of the Rules for the Classification and Construction of Sea-Going Ships

---

Director General

Konstantin G. Palnikov

---

We hereby inform that Parts VI "Fire Protection", VII "Machinery Installations", IX "Machinery", X "Boilers, Heat Exchanges and Pressure Vessels" and XVII "Distinguishing Marks and Descriptive Notations in the Class Notation Specifying Structural and Operational Particulars of Ships" of the Rules for the Classification and Construction of Sea-Going Ships for the Classification and Construction of Sea-Going Ships, 2018, ND No. 2-020101-104-E, shall be amended as specified in the Appendix to the Circular Letter.

Insert text here

---

It is necessary to do the following:

1. Apply provisions of the Circular Letter during review and approval of technical documentation on ships.
  2. Bring the content of the Circular Letter to the notice of the RS surveyors and interested organizations in the area of the RS Branch Offices' activity.
- 

List of ND amended and introduced paras/chapters/sections (to specify in the List of Circular Letters (form 8.3.36)):

Part VI: Table 3.1.2.1, paras 3.2.3.6, 3.12.1;

Part VII: paras 2.1.8, 3.3.1, 4.5.11, 4.5.13.3;

Part IX: paras 9.1.1, 9.5.1;

Part X: Chapter 1.8, para 1.8.2;

Part XVII: paras 3.5.2.2.4, 3.5.3.3.2, 3.5.3.3.3, 3.5.3.3.4, 3.5.3.3.8, 3.6.2.2.1, 3.6.3.3.2, 3.6.3.3.3, 3.6.3.3.8, 3.6.3.6.4

---

Person in charge: Ekaterina A. Shvedova 313

(812) 312-39-85

"Thesis" System No. 18-251114

**RULES FOR THE CLASSIFICATION AND CONSTRUCTION OF SEA-GOING SHIPS,  
2018, ND No. 2-020101-104-E**

**PART VI. FIRE PROTECTION**

**Table 3.1.2.1.** Footnote 15 shall be supplemented by the following text:

"This requirement does not apply to fishing vessels of less than 500 gross tonnage."

**Para 3.2.3.6** shall be amended in the Russian version only.

**Para 3.12.1** shall be supplemented by the following text:

"The provisions of this Chapter do not apply to fishing vessels."

**PART VII. MACHINERY INSTALLATIONS**

**Para 2.1.8** shall be supplemented by a new paragraph reading as follows:

"Another speed may be set for the ships intended for navigation in geographically restricted areas while providing sufficient speed to maintain the ship's handling capability in load condition."

**Para 3.3.1** shall be amended in the Russian version only.

**Para 4.5.11** shall be amended to read:

"**4.5.11** In fishing vessels of more than 1000 gross tonnage one means of escape from machinery spaces of category A may be provided on the condition that it leads directly onto the open deck, the spaces are entered only periodically and the maximum travel distance to the door (hatch) leading directly onto open deck from the control stations of the equipment located in the space is 5 m or less. In cargo ships of less than 1000 gross tonnage, the Register may dispense with one of the means of escape from machinery spaces of category A, due regard being paid to the dimension and disposition of the upper part of the space. In addition, the means of escape in these ships need not comply with the requirements for an enclosure listed in paragraph 4.5.10.1."

**Para 4.5.13.3** shall be amended to read:

".3 escape routes that pass only through stairways and/or corridors are considered as providing "direct access to the open deck" if outside the steering gear spaces they have continuous fire shelter equivalent to steering gear spaces or stairways and corridors, whichever is greater."

## **PART IX. MACHINERY**

**Para 9.1.1** shall be supplemented by the following text:

"The requirements of 9.2.2, 9.2.3 are applicable to engines operating on gas with a maximum working gas pressure of more than 1,0 MPa."

**Para 9.5.1** shall be supplemented by the following text:

"For engines operating on gas with a maximum working gas pressure of not more than 1,0 MPa, the use of other design solutions is allowed provided that proving calculations or experimental data are provided."

## **PART X. BOILERS, HEAT EXCHANGERS AND PRESSURE VESSELS**

**Chapter 1.8** shall be renamed reading as follows:

**"1.8 BOILER ROOMS"**.

**Para 1.8.2** shall be deleted.

## **PART XVII. DISTINGUISHING MARKD AND DESCRIPTIVE NOTATIONS IN THE CLASS NOTATION SPECIFYING STRUCTURAL AND OPERATIONAL PARTICULARS OF SHIPS**

**Para 3.5.2.2.4** shall be amended to read:

**3.5.2.2.4** Where NO<sub>x</sub>-reducing device is used, it shall be considered as the engine component. When for NO<sub>x</sub> reduction a selective catalytic reduction (SCR) system is used, the requirements of IMO resolution MEPC.291(71) shall be complied with."

**Para 3.5.3.3.2** shall be amended to read:

**3.5.3.3.2** To keep cargo spills within the cargo area, provision shall be made for a permanent continuous coaming on the cargo deck extending from side to side and from a point 0,2L forward of amidships to the aft end of the cargo deck with height dimensions given in Table 3.5.3.3.2."

**Table 3.5.3.3.2.** The column heading "Minimum heights of continuous coaming" shall be replaced by:

"Height dimensions of continuous coamings";

in the last column the values of aft ends of cargo deck for ships of 100000 t deadweight and above shall be replaced by "0,30 m".

**Para 3.5.3.3.3** shall be amended to read:

**"3.5.3.3.3** To collect possible oil spills during cargo operations the main deck in the cargo area shall be fitted with a system for collection of the spilled cargo with its accumulation in a holding tank or a slop tank.

Collection of the spilled cargo may be performed using particular pump and pipes located in the cargo area or by gravity drainage through specially provided pipes. The system shall be provided with means for removal of cargo residues from the pipes, when the collection of the spilled cargo is over.

Automatic gravity drainage shall be used during cargo operations where cargo spills may occur, and shall not be used under normal conditions when at sea. For gravity drainage, each pipe of deck system shall be arranged with a manually operated valve opened only during cargo operations and an automatic scupper."

**Para 3.5.3.3.4** shall be amended to read:

**"3.5.3.3.4** On oil tankers, chemical tankers and NLS tankers, the points where cargo hoses are connected to cargo manifolds shall be fitted with pipes for drainage of leaks to a holding tank or a slop tank.

The trays shall have the following minimum dimension:

tray length shall be so that the cargo manifold doesn't extend beyond forward and aft ends of the tray;

width — at least 1,8 m, at that the spill tray extends at least 1,2 m outboard of the end of the manifold flange;

minimum depth — 0,3 m".

**Para 3.5.3.3.8.** In the first paragraph the word "pipes" shall be replaced by the word "manifolds";

the second paragraph shall be introduced reading as follows:

"These requirements shall not be applied to locations of receiving fuel and lubricating oil manifolds provided on general location area together with cargo manifolds, the locations of which shall be fitted with trays according to 3.5.3.3.4."

**Para 3.6.2.2.1** shall be amended to read:

"Compliance with the requirements shall be confirmed in accordance with 3.5.2.2.1 — 3.5.2.2.5 and 3.5.2.2.9 — 3.5.2.2.10."

**Paras 3.6.2.2.1 — 3.6.2.2.4** shall be deleted.

**Para 3.6.3.3.2.** The words "deck scupper" shall be deleted.

**Para 3.6.3.3.3** shall be amended to read:

**"3.6.3.3.3** On oil tankers, chemical tankers and NLS tankers where cargo hoses are connected to cargo manifolds, the provision shall be made for spill trays with dimensions and pipes according to 3.5.3.3.4."

**Para 3.6.3.3.8** shall be amended to read:

"In addition to the requirements specified in 3.5.3.3.8, locations on the open deck in the areas of receiving fuel and lubricating oil manifolds shall be fitted with a system for collection of the spilled cargo with its accumulation in a holding tank or a slop tank.

Collection of the spilled cargo may be performed using particular pump and pipes located in the areas of receiving fuel and lubricating oil manifolds or by gravity drainage through specially provided pipes. Automatic gravity drainage shall be used during bunkering operation where fuel and oil spills may occur. For gravity drainage, each pipe of deck system shall be arranged with a manually operated valve opened only during bunkering operation and an automatic scupper."

**Para 3.6.3.6.4.** The second sentence shall be amended to read:

"When the ship is operated in special areas defined in compliance with the amendments to Annex IV to MARPOL 73/78 in IMO resolution MEPC.200(62), the above plant shall have a Certificate of type approval for sewage treatment plants in compliance with IMO resolution MEPC.227(64), including provisions specified in 4.2 of the resolution."

Российский морской регистр судоходства  
**Правила классификации и постройки морских судов**  
**Часть VII**  
**Механические установки**

Russian Maritime Register of Shipping  
**Rules for the Classification and Construction of Sea-Going Ships**  
**Part VII**  
**Machinery Installations**

The edition is prepared  
by Russian Maritime Register of Shipping  
8, Dvortsovaya Naberezhnaya,  
191186, St. Petersburg,  
Russian Federation  
[www.rs-class.org/en/](http://www.rs-class.org/en/)