

**RUSSIAN MARITIME REGISTER OF SHIPPING**

---

**RULES**  
**FOR THE CLASSIFICATION**  
**AND CONSTRUCTION**  
**OF SEA-GOING SHIPS**

**Part XVI**

**HULL STRUCTURE AND STRENGTH**  
**OF GLASS-REINFORCED PLASTIC SHIPS**  
**AND BOATS**



Saint-Petersburg  
Edition 2017

Rules for the Classification and Construction of Sea-Going Ships of Russian Maritime Register of Shipping have been approved in accordance with the established approval procedure and come into force on 1 January 2017.

The present twentieth edition of the Rules is based on the nineteenth edition (2016) taking into account the additions and amendments developed immediately before publication.

The unified requirements, interpretations and recommendations of the International Association of Classification Societies (IACS) and the relevant resolutions of the International Maritime Organization (IMO) have been taken into consideration.

The Rules are published in the following parts:

Part I "Classification";

Part II "Hull";

Part III "Equipment, Arrangements and Outfit";

Part IV "Stability";

Part V "Subdivision";

Part VI "Fire Protection";

Part VII "Machinery Installations";

Part VIII "Systems and Piping";

Part IX "Machinery";

Part X "Boilers, Heat Exchangers and Pressure Vessels";

Part XI "Electrical Equipment";

Part XII "Refrigerating Plants";

Part XIII "Materials";

Part XIV "Welding";

Part XV "Automation";

Part XVI "Hull Structure and Strength of Glass-Reinforced Plastic Ships and Boats";

Part XVII "Distinguishing Marks and Descriptive Notations in the Class Notation Specifying Structural and Operational Particulars of Ships";

Part XVIII "Common Structural Rules for Bulk Carriers and Oil Tankers". The text of the Part is identical to that of the IACS Common Structural Rules;

Part XIX "Additional Requirements for Structures of Container Ships and Ships, Dedicated Primarily to Carry their Load in Containers". The text of the Part is identical to IACS UR S11A "Longitudinal Strength Standard for Container Ships" (June 2015) and S34 "Functional Requirements on Load Cases for Strength Assessment of Container Ships by Finite Element Analysis" (May 2015).

Parts I to XVII are published in electronic format and hard copy in Russian and English. In case of discrepancies between the Russian and English versions, the Russian version shall prevail.

Parts XVIII to XIX are published in English and in electronic format only.

*As compared to the previous edition (2016), the twentieth edition contains the following amendments.*

**RULES FOR THE CLASSIFICATION AND CONSTRUCTION OF SEA-GOING SHIPS**

**PART XVI. HULL STRUCTURE AND STRENGTH OF GLASS-REINFORCED PLASTIC SHIPS AND BOATS**

1. Editorial amendments have been made.

# CONTENTS

## PART XVI. HULL STRUCTURE AND STRENGTH OF GLASS-REINFORCED PLASTIC SHIPS AND BOATS

|          |  |    |             |  |    |
|----------|--|----|-------------|--|----|
| <b>1</b> | <b>General</b>                           | 5  | 2.13        | Stems, sternframes, propeller shaft brackets<br>and bilge keels                                  | 20 |
| 1.1      | Application                              | 5  | 2.14        | Casings of engine and boiler rooms, hatch<br>and fan coamings                                    | 21 |
| 1.2      | Definitions and explanations             | 5  | <b>3</b>    | <b>Strengthening in ships for navigation<br/>in ice</b>  | 22 |
| 1.3      | General                                  | 5  | 3.1         | General  | 22 |
| 1.4      | Scope of surveys                         | 5  | 3.2         | Ice strengthening for ships of ice class <b>Ice2</b>   | 22 |
| 1.5      | Materials                                | 6  | <b>4</b>    | <b>Lifeboat hull</b>   | 23 |
| 1.6      | Framing system and spacing               | 6  | 4.1         | General  | 23 |
| 1.7      | Matting-in connections and fastenings    | 6  | 4.2         | Shell  | 23 |
| <b>2</b> | <b>Hull and superstructures of ships</b> | 9  | 4.3         | Framing  | 23 |
| 2.1      | General                                  | 9  | 4.4         | Attachment of lifting gear and<br>equipment  | 24 |
| 2.2      | Side and bottom shell                    | 12 | Appendix 1. | Recommended types of<br>glass-reinforced plastics  | 26 |
| 2.3      | Bottom framing                           | 13 | Appendix 2. | Physical and mechanical<br>properties of glass-reinforced plastics                               | 27 |
| 2.4      | Side framing                             | 14 | Appendix 3. | Guidance for determination<br>of hull member scantlings of ships<br>and lifeboats by calculation | 30 |
| 2.5      | Decks and deck framing                   | 15 |             |  |    |
| 2.6      | Pillars                                  | 16 |             |  |    |
| 2.7      | Bulkheads                                | 17 |             |  |    |
| 2.8      | Tanks                                    | 18 |             |  |    |
| 2.9      | Superstructures and deckhouses           | 18 |             |  |    |
| 2.10     | Openings in structures                   | 19 |             |  |    |
| 2.11     | Bulwark                                  | 20 |             |  |    |
| 2.12     | Engine seatings                          | 21 |             |  |    |

# PART XVI. HULL STRUCTURE AND STRENGTH OF GLASS-REINFORCED PLASTIC SHIPS AND BOATS

## 1 GENERAL

### 1.1 APPLICATION

**1.1.1** The requirements of the present Part of the Rules apply to:

**.1** displacement ships of glass-reinforced plastic from 12 to 30 m in length having the speed  $v \leq 3,05\sqrt{L}$  knots and the dimension ratios within the following limits:

length to depth ratio  $L : D = 6...10$ ;

breadth to depth ratio  $B : D = 2...2,5$ ;

length to breadth ratio  $L : B = 3...5$ .

Where the dimension ratios are beyond the specified limits, the structure and scantlings of the hull are subject to special consideration by the Register;

**.2** lifeboats from 4,5 to 12 m in length.

**1.1.2** The requirements of the present Part are also applicable to:

**.1** displacement ships from (5)<sup>1</sup> up to 12 m and those over 30 m in length, the structure of ships over 30 m in length being subject to special consideration by the Register;

**.2** hydrogliders, air-cushion vehicles and hydrofoil ships, the structure of such ships being subject to special consideration by the Register.

### 1.2 DEFINITIONS AND EXPLANATIONS

**1.2.1** The definitions and explanations relating to the general terminology of the Rules are given in 1.1, Part I "Classification".

The definitions of dimensions of ships comply with the provisions of Part II "Hull".

For the purpose of the present Part the following definitions have been adopted.

**Single-skin construction** is a construction comprising a single-skin laminate stiffened by framing members.

**Double-skin construction** is a construction comprising two single-skin laminates interconnected by framing members.

**Sandwich construction** is a construction comprising two single-skin laminates interconnected by a core of plastic foam, honeycomb structure, etc. In this type of construction the core is load-bearing and takes up the load together with the laminates.

<sup>1</sup>References for ships below 12 m in length are shown in parentheses.

### 1.3 GENERAL

**1.3.1** The requirements of the present Part apply to:

**.1** hulls moulded either as a whole or in two halves (starboard and portside), which are jointed together along the keel, stem and sternframe;

**.2** ships with the following connections of hull sections:

shell skin along the centre line;

deck to side;

superstructures and deckhouses to deck;

**.3** ships with shell, deck and strength bulkheads of single-skin construction;

**.4** ships with deckhouse and superstructure sides and ends of single-skin and sandwich construction;

**.5** lifeboat hulls of single-skin, double-skin and sandwich construction.

**1.3.2** The scantlings of structural members of sandwich and double-skin hull structures of ships as well as application of composite structures are in each case subject to special consideration by the Register unless special requirements are given in the present Part.

**1.3.3** On drawings of glass-reinforced plastic structures the thickness of laminates, in mm, as well as the number of reinforcing material layers and the total mass of reinforcement in kg per square metre of the laminate area shall be shown.

**1.3.4** The hull moulding technique is subject to approval by the Register in each case.

**1.3.5** Types of structures other than those stated in the present Part may be approved by the Register, provided the requirements of 1.3.3.1, General Regulations for the Classification and Other Activity are met.

### 1.4 SCOPE OF SURVEYS

**1.4.1** The general provisions for survey of the hull are set forth in General Regulations for the Classification and Other Activity.

**1.4.2** After consideration and approval of the technical design of a ship as a whole, the following items shall undergo survey by the Register during the hull construction:

**.1** basic materials for moulding hull structures;

**.2** condition and microclimate of working shops;

**.3** equipment to be used in moulding hull structures;

.4 moulding of shell assemblies with relevant framing;

.5 moulding of deck assemblies;

.6 moulding of bulkheads;

.7 moulding of tanks;

.8 moulding of superstructures and deckhouses;

.9 moulding of seatings for main machinery as well as for other machinery and arrangements subject to survey by the Register;

.10 moulding of coamings, companions and similar guards for openings in hull;

.11 stems and sternframes, shaft brackets.

1.4.3 Prior to manufacturing structures listed in 1.4.2, technical documentation for the hull in the scope specified in 3.1.3, Part I "Classification" shall be submitted to the Register for approval.

1.4.4 During construction the hull structures mentioned in 1.4.2 are subject to survey as regards the compliance with the requirements of Part XIII "Materials" and with the technical documentation approved.

1.4.5 The procedure and results of tests for rigidity and strength of completed structures are in each case subject to special consideration by the Register.

## 1.5 MATERIALS

1.5.1 In the present Part the use of glass-reinforced plastics of the types given in Appendix 1 is specified.

1.5.2 In addition to the plastics mentioned in Appendix 1, glass-reinforced plastics containing reinforcements and binders in alternative combinations as well as with alternative reinforcement schemes may be used, provided that detailed information on their mechanical properties, which is submitted, is approved by the Register.

## 1.6 FRAMING SYSTEM AND SPACING

1.6.1 The present Part deals with the transverse system of framing of ship's hull.

In the case of longitudinal or combined system of framing the hull structure design and scantlings are subject to special consideration by the Register.

1.6.2 For standard spacings of transverse framing, refer to Table 1.6.2.

Table 1.6.2

| Length of ship, m | Spacing, mm |
|-------------------|-------------|
| 12(5)...15        | 350         |
| 15 < $L$ < 25     | 400         |
| 25...30           | 450         |

Where the spacing adopted is different from that given in Table 1.6.2, the thicknesses and scantlings of framing members are recalculated in accordance with the requirements of 2.2, 2.3, 2.5.

1.6.3 The frame spacing in the fore peak shall not exceed:

300 mm with  $L$  from 12 (5) to 15 m;

350 mm with  $L$  over 15 and below 25 m;

400 mm with  $L$  from 25 to 30 m (inclusive).

1.6.4 The spacing of stiffeners of the watertight transverse bulkheads is assumed to be equal to the spacing of the hull framing.

For the fore peak bulkhead the spacing of stiffeners is assumed to be equal to the spacing at the fore end.

For the superstructure and deckhouse sides the spacing shall be equal to that of the single-skin construction hull.

## 1.7 MATTING-IN CONNECTIONS AND FASTENINGS

1.7.1 The connection of longitudinal and transverse framing members is made by means of matting-in angles (wet angles), which are formed in situ and in which glass mats are used as reinforcement. By way of exception glass fabric of satin or plain weave may be used. The use of glass roving cloth is not permitted. The surfaces to be jointed shall be thoroughly cleaned prior to laying-up the matting-in connections.

On agreement with the Register, the matting-in angles may be moulded by spraying.

1.7.2 The thickness of the matting-in angle shall be equal to half the thickness of the stiffener web in the case of tee-shaped sections and to a full thickness of the stiffener web in the case of closed box sections. The width of the matting-in angle flange and the

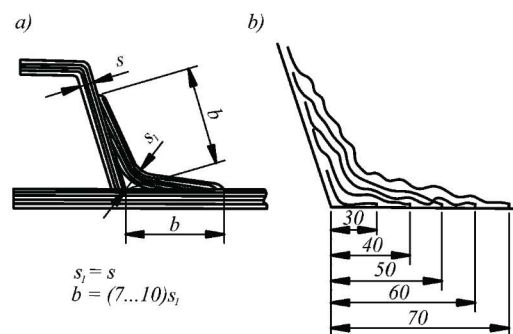

Fig. 1.7.2-1:

$a$  — scantling of matting-in connection;

$b$  — diagram of laying-up layers of glass mat or glass fabric strips

|            |    |    |    |    |    |    |
|------------|----|----|----|----|----|----|
| $s_1$ , mm | 3  | 4  | 5  | 6  | 8  | 10 |
| $b_1$ , mm | 30 | 30 | 40 | 50 | 60 | 70 |

diagram of laying-up the reinforcement shall be in accordance with Figs. 1.7.2-1 and 1.7.2-2. In any case, the width of the matting-in angle flanges shall not be less than 30 mm for stiffeners and 50 mm for transverse watertight bulkheads.

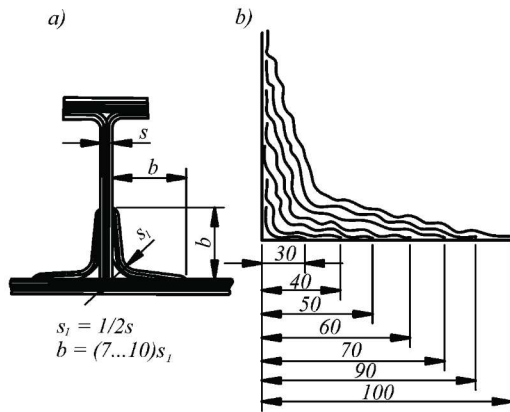

Fig. 1.7.2-2:

a — scantlings of matting-in connection; b — diagram of laying-up layers of glass mat or glass fabric strips

|            |    |    |    |    |    |    |    |     |
|------------|----|----|----|----|----|----|----|-----|
| $s_1$ , mm | 3  | 4  | 5  | 6  | 8  | 10 | 12 | 14  |
| $b_1$ , mm | 30 | 30 | 40 | 50 | 60 | 70 | 90 | 100 |

1.7.3 The thickness of matting-in angles of bulkheads, platforms, superstructures and deckhouse sides and ends shall be equal to that of the bulkhead sheathing, platform planking, superstructure or deckhouse side and end, respectively.

1.7.4 For bolted connections the following conditions shall be met:

- .1 bolting shall not be less than three bolt diameters away from the edge of the laminate;
- .2 the bolt diameter shall be equal to the thickness of the thickest laminate to be connected;
- .3 bolts shall not be closer spaced than four diameters apart;
- .4 parts of the bolted connections shall be protected with anticorrosive coating or made of corrosion-resistant materials;
- .5 washers of not less than 2,5 times the bolt diameter shall be fitted under the bolt head and nut, the washer thickness being 0,1 times the bolt diameter, but not less than 1,5 mm.

1.7.5 Connections made with the use of riveting shall be specially considered by the Register.

1.7.6 Non-essential or low-stresses connections are permitted to be made by means of matting-in butts (refer to Fig. 1.7.6). The contact surfaces shall be thoroughly cleaned prior to the laying-up of strap layers.

1.7.7 Where the hull is moulded in two (starboard and port) halves, they shall be connected along the

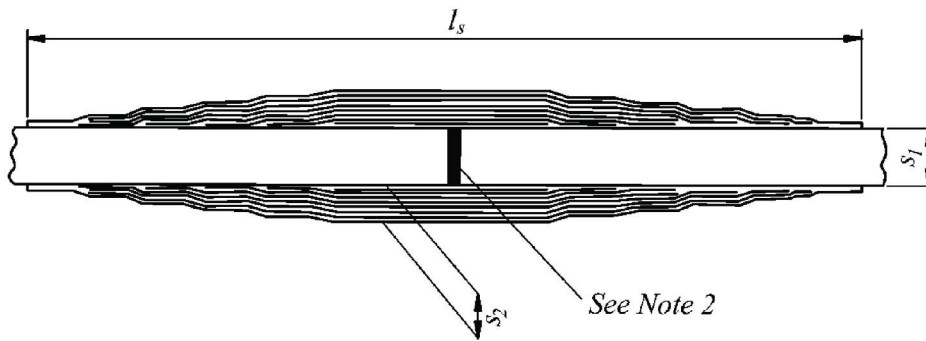

Fig. 1.7.6:

$l_s$  — width of the matted-on strap: ( $l_s = 200 + 15s_1$ ); ( $s_2 = 0,5s_1$ );  $s_1$  — thickness of the laminates being connected;  $s_2$  — thickness of the matted-on strap

| $s_1$ , mm | $s_2$ , mm | Glass fabric layer numbers       |     |     |     |     |     |     |     |     |     |     |     |     |     |
|------------|------------|----------------------------------|-----|-----|-----|-----|-----|-----|-----|-----|-----|-----|-----|-----|-----|
|            |            | 1                                | 2   | 3   | 4   | 5   | 6   | 7   | 8   | 9   | 10  | 11  | 12  | 13  | 14  |
|            |            | Width of the matted-on strap, mm |     |     |     |     |     |     |     |     |     |     |     |     |     |
| 6          | 3          | 100                              | 150 | 150 | 200 | 200 | 250 | 300 |     |     |     |     |     |     |     |
| 8          | 4          | 100                              | 100 | 150 | 150 | 150 | 200 | 250 | 250 | 300 |     |     |     |     |     |
| 10         | 3          | 100                              | 100 | 150 | 150 | 200 | 200 | 250 | 250 | 300 | 300 |     |     |     |     |
| 14         | 7          | 100                              | 100 | 150 | 150 | 200 | 200 | 250 | 250 | 300 | 300 | 330 | 350 | 400 | 400 |

- Notes: 1. The glass fabric warp shall be oriented perpendicularly to the butts in the laminates.  
 2. The space between the laminates shall be 1 to 2 mm.  
 3. The strap material is a laminate on the basis of glass fabric of satin or plain weave. Glass mats are not permitted.

centre line by means of matted-on straps (refer to Fig. 1.7.7). The straps shall be moulded of glass-reinforced plastics of type III or IV for any length of the hull. The thickness  $s$  of each strap shall be 0,7 times the keel plate thickness  $s_k$  (refer to Table 2.2.1). The entire width of the matted-on straps shall not be less than  $200 \text{ mm} + 15s_k$ .

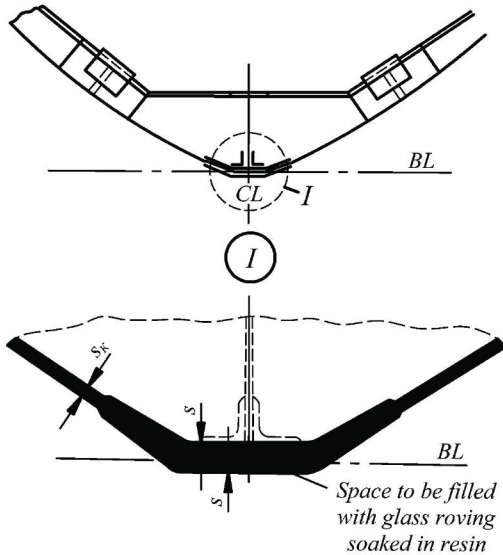

Fig. 1.7.7

**1.7.8** The thickness of the matted-on straps shall reduce towards the edges down to the thickness of one layer of glass fabric. This reduction in thickness is achieved by gradual increase in the width of the laid up tapes, the first layer based on a 100 mm tape (50 mm on each side) and subsequent layers formed by tapes 140 mm, 180 mm and so on wide laid up in the number of one or from two to three at a time.

**1.7.9** Deck-to-side connection shall be made by means of inner and outer matting-in angles (straps) in accordance with Fig. 1.7.9. The angles shall be moulded of glass-reinforced plastics of type III or IV. The width of both flanges of the matting-in angles ( $2b$ ) shall not be less than  $200 \text{ mm} + 15s_{sh}$  (where  $s_{sh}$  is the sheerstrake thickness). The thickness of the matting-in angle shall be taken equal to  $0,7 s_{sh}$ .

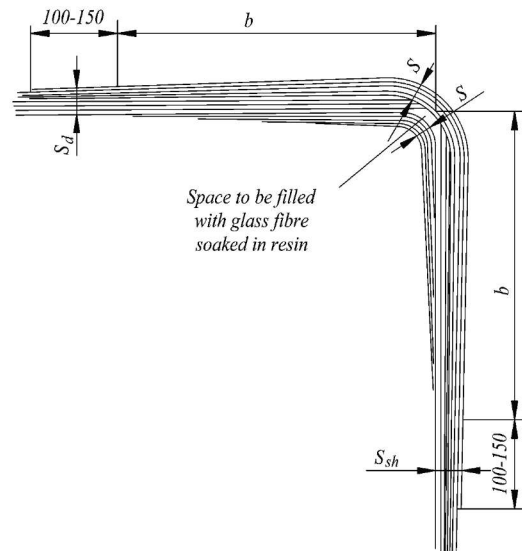

Fig. 1.7.9:

$s_{sh}$  — sheerstrake thickness;  $s_d$  — deck laminate thickness;  
 $s$  — thickness of the matting-in single angle;  $b$  — half width of flanges of the matting-in angle

Note. Additional layer of fabric shall be laid onto the outer surface of the deck and side shell laminate to overlap the matting-in angle for 100 to 150 mm on each side, the direction of fabric warp being along the hull.

**1.7.10** The layers in the matting-in angles shall be distributed as specified in 1.7.2.

## 2 HULL AND SUPERSTRUCTURES OF SHIPS

### 2.1 GENERAL

**2.1.1** The thickness of the shell and deck laminates as well as of the bulkhead and other laminates shall be determined from Figs. 2.1.1-1, 2.1.1-2 and 2.1.1-3 depending on the permissible bending moment  $m_{perm}$  acting on a strip 1 cm wide, which is given in Table 2.2.1.

The thickness of laminates with the glass content as specified in line No. 1 of Tables 1 to 6 presented in Appendix 2 shall be determined from Fig. 2.1.1-1.

The thickness of laminates with the glass content as specified in lines Nos. 2 and 3 of the above-mentioned Tables shall be determined from Figs. 2.1.1-2 and 2.1.1-3.

The reinforcement schemes given in lines Nos. 1 and 2 of Tables 1, 2, 5 and 6 of Appendix 2 are used for moulding sides and bottom shell, decks, divisions, etc.

The reinforcement scheme given in line No. 3 of Tables 3 and 6 and in line 2 of Table 1 is used for framing members, which shall be moulded and squeezed in special devices during manufacture.

**2.1.2** The present Part provides for hull framing members to be made of closed box sections of glass-reinforced plastics, type  $I_2$ , and of T-shaped sections with a face plate of glass-reinforced plastics, type  $III_3$ , and the web of glass-reinforced plastics, type  $I_2$ .

**2.1.3** The scantlings of framing members shall be determined from Figs. 2.1.3-1, 2.1.3-2 and 2.1.3-3 depending on the section modulus of stiffeners with the associated face plate.

The scantlings of stiffeners of closed box section are determined from Fig. 2.1.3-1.

The scantlings of T-shaped stiffeners are determined from Figs. 2.1.3-2 and 2.1.3-3, Fig. 2.1.3-3 being the scaled-up original of Fig. 2.1.3-2.

The scantlings of bottom stiffeners (centre girder and side girders) shall be determined in accordance with 2.3.5.

The recommended structural types of closed-box and T-shaped sections are shown in Figs. 2.1.3-4 and 2.1.3-5.

**2.1.4** The scantlings of the framing members are permitted to be determined according to Appendix 3.

**2.1.5** The width of the associated plate is taken to be 1/6 of the stiffener span, provided that the panel is of glass-reinforced plastics, types I, V, VI, VII and VIII, or 1/10 of the stiffener span, provided that the panel is of glass-reinforced plastics, type II, but it shall not be more than the distance between adjacent parallel stiffeners.

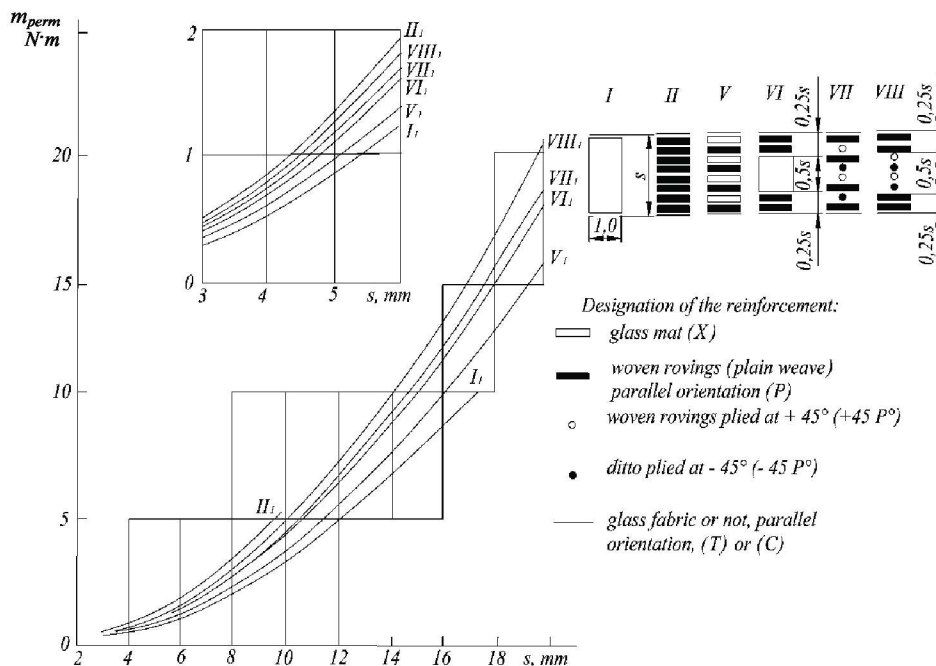

Fig. 2.1.1-1

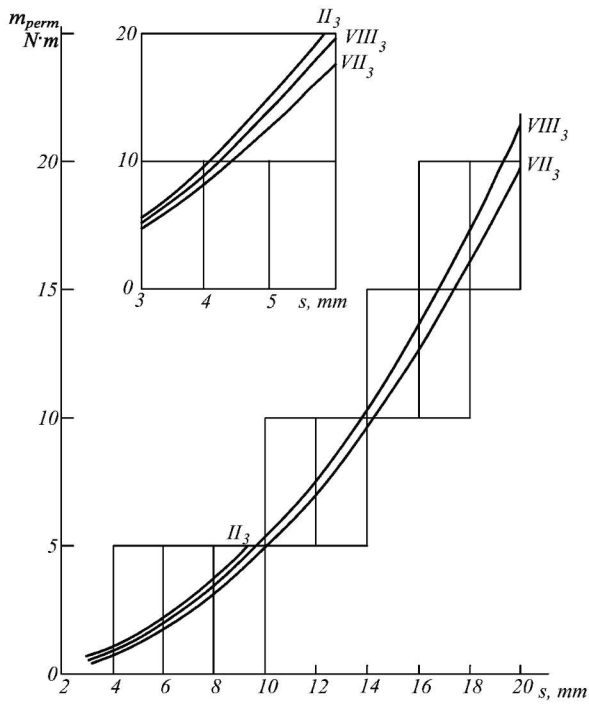

Fig. 2.1.1-2

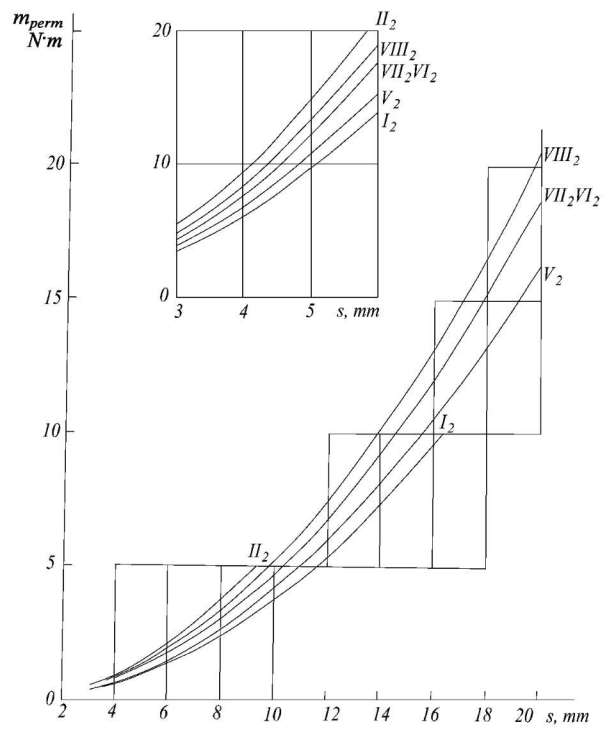
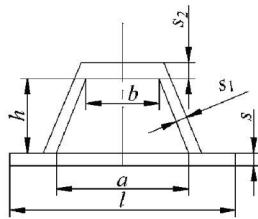

Fig. 2.1.1-3



$$\begin{aligned}
 a &= (1,4 \dots 2,0)h; \\
 b &= (0,7 \dots 1,0)h; \\
 S_1 &= (\frac{1}{20} \dots \frac{1}{15})h; \\
 S_2 &= 3 S_1; \\
 F &= b S_2;
 \end{aligned}$$

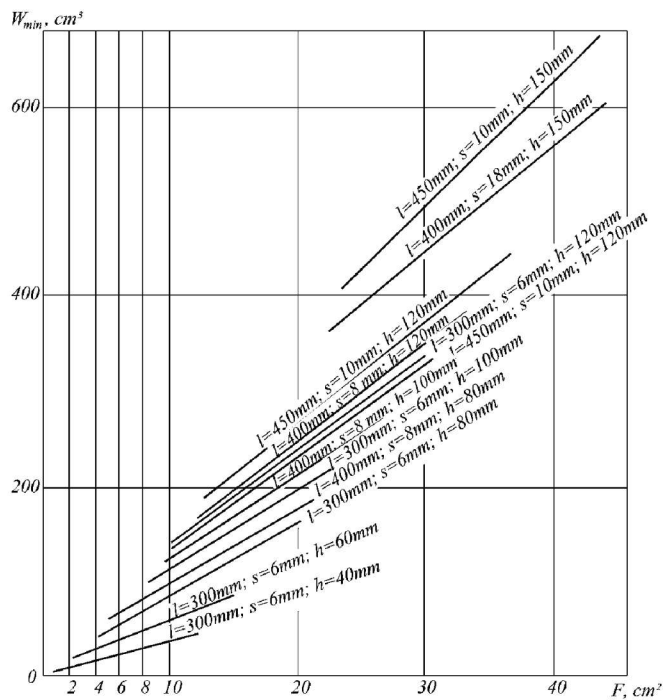

Fig. 2.1.3-1

Note. Stiffener with associated plate of glass plastic type I<sub>2</sub>.

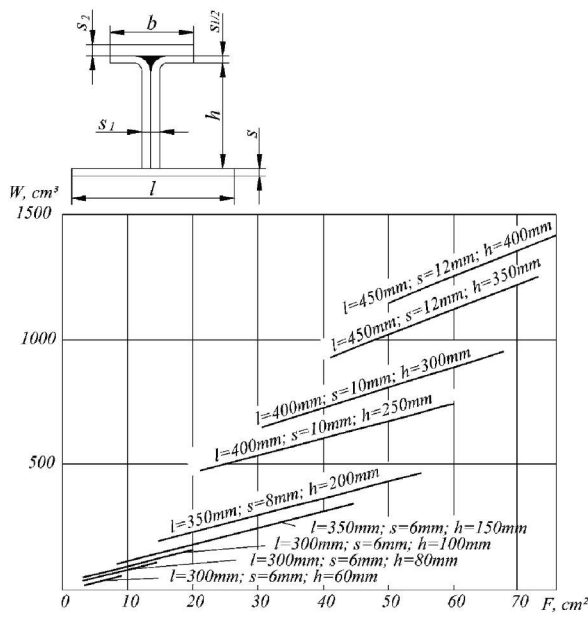

Fig. 2.1.3-2

| $b$                                    | $s_1$                                | $s_2$            |
|--|--------------------------------------|------------------|
| $(\frac{1}{1,5} \dots \frac{1}{1,3})h$ | $(\frac{1}{10} \dots \frac{1}{20})h$ | $(2 \dots 3)s_1$ |
| $F = b \cdot s_2$                      |                                      |                  |

Notes: 1. Face plate of glass plastic type III<sub>3</sub>, the associated plate of glass plastic type VII<sub>2</sub>, with  $E_{VII} - 0,7E_{III}$  (where  $E$  is the modulus of elasticity).  
 2. Web of glass plastic type I<sub>2</sub>.

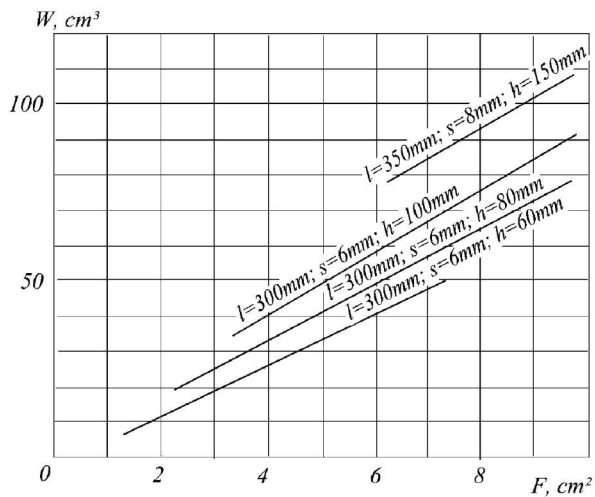

Fig. 2.1.3-3

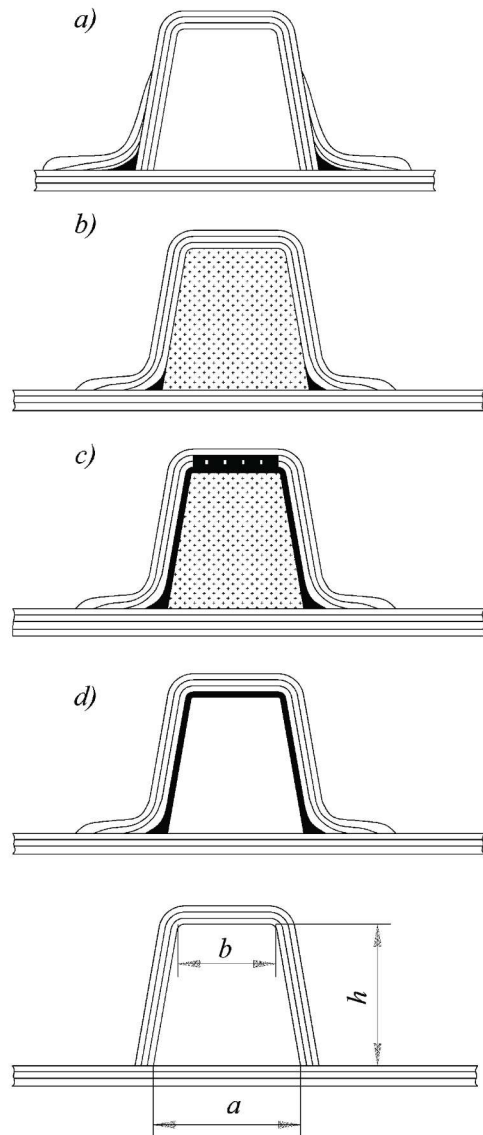

Fig. 2.1.3-4:

$a$  — pre-moulded stiffener;  $b$  — stiffener moulded in situ, with core of foamed plastic;  $c$  — ditto, with face plate reinforced;  $d$  — stiffener moulded in situ over a former of sheet aluminium  
 Notes: 1. Reinforcement in face on the basis of glass fabric or glass rovings.  
 2. These sketches do not indicate the relations for longitudinal framing members.

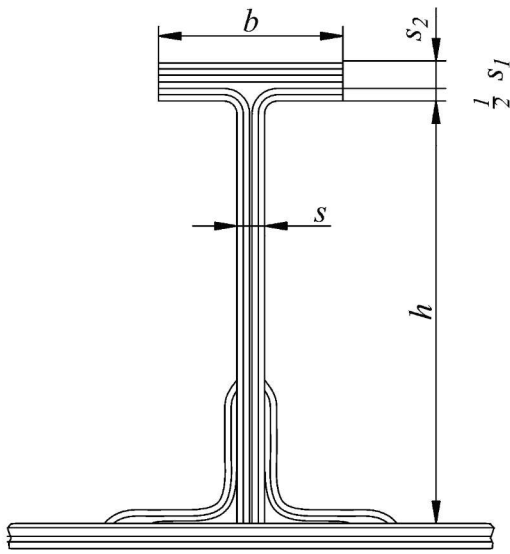

Fig. 2.1.3-5

| $b$                                    | $s_1$                                | $s_2$           |
|--|--------------------------------------|-----------------|
| $(\frac{1}{1,5} \dots \frac{1}{3,0})h$ | $(\frac{1}{10} \dots \frac{1}{20})h$ | $(2\dots 3)s_1$ |

Note. The warp of glass fabric in face plate shall be directed along the stiffener.

**2.2 SIDE AND BOTTOM SHELL**

**2.2.1** The thickness of the side and bottom shell shall be determined from Figs. 2.1.1-1 and 2.1.1-2 depending on the permissible bending moment value given in Table 2.2.1.

**2.2.2** The minimum side and bottom shell thickness shall not be less than:

**.1** 4 mm for sides and 5 mm for bottom in case of single-skin construction with reinforcement of any type;

**.2** 3 mm for sides and 4 mm for bottom in case of double-skin or sandwich construction.

**2.2.3** Side and bottom shell is permitted to be moulded of glass-reinforced plastics of the following types:

- I — for hulls from 12(5) to 15 m in length;
- II — for hulls from (5) to (10) m in length;
- V — for hulls from 12(5) to 30 m in length;
- VII — for hulls from 12(10) to 30 m in length.

**2.2.4** In the case of shell thickness between 3 and 6 mm provision shall be made for a 40 mm overlap of butts in reinforcements. Seams are formed without overlapping.

Table 2.2.1

| Length of ship, m | Spacing, mm | $m_{perm}$ , N·m |            | Width, mm  |              |
|-------------------|-------------|------------------|------------|------------|--------------|
|                   |             | Bottom shell     | Side shell | Plate keel | Sheer-strake |
| 1                 | 2           | 3                | 4          | 5          | 6            |
| (5)               | (350)       | (1,4)            | (0,8)      | (400)      | (300)        |
| (7,5)             | (350)       | (2,0)            | (1,3)      | (475)      | (400)        |
| (10)              | (350)       | (3,1)            | (2,0)      | (550)      | (475)        |
| 12                | 350         | 4,2              | 2,8        | 600        | 575          |
| 15                | 350/400     | 5,2/6,7          | 3,5/4,5    | 675        | 650          |
| 17,5              | 400         | 8,0              | 5,2        | 750        | 750          |
| 20                | 400         | 9,0              | 6,0        | 825        | 825          |
| 22,5              | 400         | 10,2             | 6,7        | 875        | 925          |
| 25                | 400/450     | 11,4/13,6        | 7,5/9,5    | 950        | 1000         |
| 27,5              | 450         | 14,8             | 10,3       | 1025       | 1100         |
| 30                | 450         | 16,0             | 11,0       | 1100       | 1200         |

Notes: 1. Where the design spacing differs from that given in column 2,  $m_{perm}$  shall be modified in the ratio of  $(\frac{\text{actual spacing}}{\text{Table spacing}})^2$ .

2. For intermediate ship lengths  $m_{perm}$  shall be determined by interpolation.

3. The thickness of the plate keel and sheerstrake is taken equal to 1,5 times the bottom shell thickness.

4. In column 5 the entire width of the plate keel is shown.

5. Reduction in thickness shall be made across the width of 50 mm for each 5 mm difference in thickness.

6. For ships of 15 and 25 m in length shown in the numerator is the smaller spacing and in the denominator — the greater spacing.

7. The following areas are considered as bottom shell:

- in ships of hard chine form — from the keel line up to the bilge;
- in ships of rounded chine form — from the keel line to  $1/3D$ .

In the case of shell thickness of 6 mm and above the butts and seams in reinforcements need not be overlapped, the number of reinforcing material layers being not less than 8.

**2.2.5** The butts and seams in each adjacent layer of the reinforcing material shall be spaced not closer than 100 mm apart.

Butts and seams are permitted to be coincident in one section after 6 layers at least.

**2.2.6** Woven rovings in layers of the diagonal lay-up shall not have butts.

**2.2.7** The thickness and width of the plate keel and sheerstrake shall be determined in accordance with Table 2.2.1 (refer to Note 3).

**2.2.8** The thickness of the stern laminates (transom included) shall not be less than that of the bottom laminates.

**2.2.9** The thickness of the shell and sheerstrake laminates in way of the fore peak shall be taken equal to that of the midship portion.

**2.2.10** The plate keel and sheerstrake shall be moulded by addition of reinforcing material layers, which shall be uniformly distributed between the shell basic layers and alternate with the latter.

The change in thickness shall be made in accordance with Table 2.2.1 (refer to Note 5).

### 2.3 BOTTOM FRAMING

**2.3.1** Floors shall be fitted at each frame.

**2.3.2** Floors of increased section modulus shall be fitted at all web frames. The depth of floors of increased section modulus shall be taken equal to that of the centre girder and side girders, whichever is greater.

**2.3.3** The scantlings of floors are taken in accordance with 2.1.2 depending on the section modulus given in Table 2.3.3.

**2.3.4** The minimum thickness of floors shall be 2 mm in the case of closed-box sections and 4 mm in the case of T-shaped sections.

**2.3.5** Where the half-breadth measured along the top edge of the floor is in excess of 0,75 m, a centre girder is required to be fitted. Where this value is in excess of 2,5 m, the fitting of one side girder on each side is required in addition to the centre girder.

The scantlings of the centre girder and side girders are given in Table 2.3.5.

**2.3.6** The intersection of the side girders with floor shall be effected in accordance with Figs. 2.3.6-1 and 2.3.6-2 without the floors being cut.

The intersection of side girders with floors of increased section modulus shall be made by means of an edge cross-lap joint (refer to Fig. 2.4.6).

**2.3.7** The depths of non-continuous longitudinals shall be reduced to the floor depth within at least three spacings at each longitudinal end.

**2.3.8** In floors and side girders water courses shall be provided. The recommended structural design of a water course is shown in Fig. 2.3.8.

**2.3.9** The connection of the bottom framing to the side framing may be effected by means of matting-in or matting-on connections.

Table 2.3.3

| Length of ship, m | Design load, kPa | Section modulus for floors of closed-box section, cm <sup>3</sup> ,<br>for 400 mm spacing, with the span, m |      |      |       |       |      |
|-------------------|------------------|---|------|------|-------|-------|------|
|                   |                  | 0,50  | 0,75 | 1,00 | 1,50  | 2,00  | 2,50 |
| (5,0)             | (20,0)           | (15)  | (25) | (50) | (100) | —     | —    |
| (7,5)             | (30,0)           | (20)  | (40) | (70) | (150) | (260) | —    |
| (10,0)            | (40,0)           | (30)  | (50) | (90) | (200) | (350) | —    |
| 12,0              | 25,0             | 15  | 30   | 60   | 130   | 220   | 350  |
| 15,0              | 30,0             | 20  | 40   | 70   | 150   | 270   | 420  |
| 17,5              | 35,0             | 25  | 50   | 80   | 180   | 310   | 490  |
| 20,0              | 38,0             | 30  | 60   | 90   | 200   | 350   | 560  |
| 22,5              | 43,0             | 35  | 70   | 100  | 230   | 400   | 630  |
| 25,0              | 47,0             | —   | 80   | 110  | 250   | 440   | 690  |
| 27,5              | 51,0             | —   | —    | 120  | 280   | 490   | 760  |
| 30,0              | 55,0             | —   | —    | —    | 300   | 530   | 830  |

**Notes:** 1. The section moduli shown in the Table are given for the spacing of 400 mm, for other spacings the section modulus shall be modified in proportion to the ratio of  $\frac{\text{spacing, mm}}{400}$ .

2. Where T-shaped sections are used, the section modulus may be reduced by the factor of three.

3. The span is measured between the floor ends where the keel is omitted; from the keel to the floor end where the keel is fitted and the side girder is omitted; from the keel to the side girder or from the side girder to the floor end, whichever is greater.

4. For ships between (5) and (10) m in length, the design load is taken with account of water impact against the bottom likely to occur when the ship is dropped into water.

5. For ships over (10) m in length, the design load is taken equal to the maximum side depth obtained at  $L:D = 6 + 0,5$  m.

6. Where the design load differs considerably from that given in the Table, the section modulus may be reduced in proportion to the ratio of  $\frac{\text{actual design load}}{\text{tabulated load}}$ .

Table 2.3.5

| Length of ship, m | Spacing, mm | Centre girder, mm |               |  | Side girder, mm |               |  |
|-------------------|-------------|-------------------|---------------|--|-----------------|---------------|--|
|                   |             | Height, mm        | Thickness, mm | Section of face plate, mm <sup>2</sup> | Height, mm      | Thickness, mm | Section of face plate, mm <sup>2</sup> |
| (5,0)             | (350)       | (150)             | (8)           | (60 × 12)                              | —               | —             | —                                      |
| (7,5)             | (350)       | (180)             | (9)           | (70 × 14)                              | —               | —             | —                                      |
| (10,0)            | (350)       | (210)             | (10)          | (80 × 15)                              | —               | —             | —                                      |
| 12,0              | 350         | 240               | 11            | 90 × 15                                | —               | —             | —                                      |
| 15,0              | 350         | 270               | 12            | 100 × 15                               | 200             | 10            | 80 × 15                                |
| 17,5              | 400         | 300               | 13            | 110 × 16                               | 225             | 11            | 90 × 15                                |
| 20,0              | 400         | 330               | 14            | 120 × 18                               | 250             | 12            | 100 × 15                               |
| 22,5              | 400         | 370               | 15            | 130 × 20                               | 275             | 13            | 110 × 16                               |
| 25,0              | 400         | 410               | 16            | 140 × 22                               | 300             | 14            | 110 × 16                               |
| 27,5              | 450         | 440               | 17            | 150 × 24                               | 325             | 15            | 120 × 18                               |
| 30,0              | 450         | 470               | 18            | 160 × 26                               | 350             | 16            | 130 × 20                               |

Notes: 1. The scantlings shown in the Table are given for a T-shaped section with the face plate of glass-reinforced plastic, type III<sub>3</sub>, and the web of glass-reinforced plastic, types I<sub>2</sub>, V<sub>2</sub>, VII<sub>2</sub>.  
2. Where closed-box sections of glass-reinforced plastic, type I<sub>2</sub>, are used, the section moduli shall be increased by the factor of three.  
3. The scantlings of longitudinal framing members are given for compartments, which length amounts to 30 per cent of the ship's length for ships between 12(5) and 20 m in length, and to 20 per cent for ships between 20 and 30 m in length. In the case of compartments of greater lengths the scantlings of the longitudinal framing members shall be considered specially.  
4. Where the actual spacing differs from that shown in the Table, the scantlings of the centre girder and side girders shall not be modified.  
5. For intermediate ship lengths the section modulus is determined by interpolation.

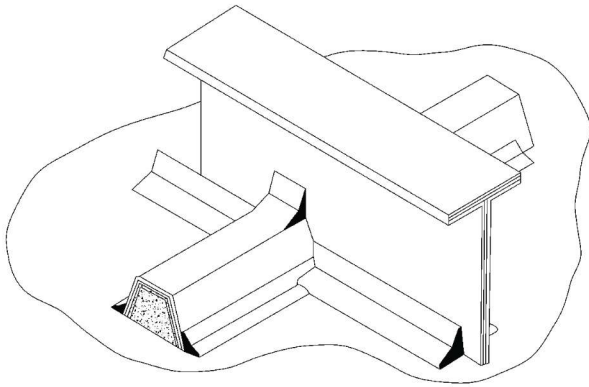

Fig. 2.3.6-1

Note. The framing member, which is formed the first, shall not be cut at a deep member.

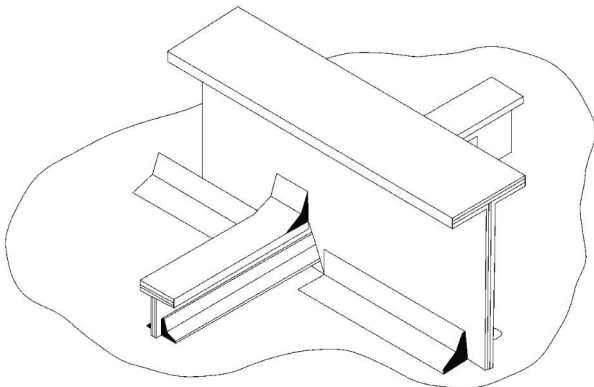

Fig. 2.3.6-2

Note. The framing member, which is formed the first, shall not be cut at a deep member.

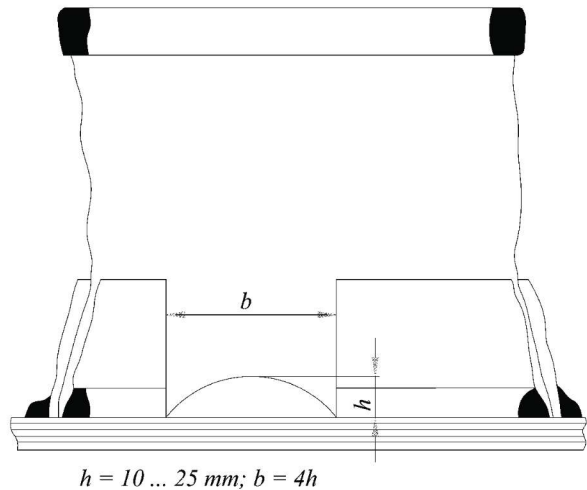

Fig. 2.3.8

Notes. The hole is cut at 1/4 of the spacing distance from the intersection with a floor.

## 2.4 SIDE FRAMING

**2.4.1** The scantlings of frames shall be taken in accordance with 2.1.2 depending on the section modulus given in Table 2.4.1.

**2.4.2** The distance between adjacent bulkheads and web frames shall not exceed 6 spacings.

**2.4.3** The section modulus of a web frame shall not be less than 5 times the frame section modulus.

**2.4.4** Where the frame span is in excess of 2,4 m, a side stringer shall be fitted.

Table 2.4.1

| Span, m | Section modulus, cm <sup>3</sup>     |     |     |                                    |     |     |
|---------|--------------------------------------|-----|-----|------------------------------------|-----|-----|
|         | Closed-box section, with spacing, mm |     |     | T-shaped section, with spacing, mm |     |     |
|         | 350                                  | 400 | 450 | 350                                | 400 | 450 |
| 1,0     | 47                                   | 54  | 61  | 12                                 | 18  | 20  |
| 1,2     | 76                                   | 87  | 98  | 29                                 | 29  | 33  |
| 1,4     | 107                                  | 128 | 138 | 35                                 | 41  | 46  |
| 1,6     | 147                                  | 159 | 180 | 47                                 | 53  | 59  |
| 1,8     | 200                                  | 228 | 256 | 70                                 | 76  | 85  |
| 2,0     | 290                                  | 330 | 370 | 93                                 | 110 | 123 |
| 2,2     | 369                                  | 420 | 470 | 123                                | 140 | 157 |
| 2,4     | 500                                  | 570 | 640 | 150                                | 189 | 210 |

Note. Where a side stringer is fitted, the section modulus of the frame shall be taken equal to 1,5 times the section modulus determined from the Table for a span measured from the deck to the side stringer or from the side stringer to the floor, whichever is greater.

**2.4.5** The section modulus of a side stringer shall be equal to that of a web frame.

**2.4.6** The intersection of a web frame and a side stringer shall be effected by means of an edge cross lap (refer to Fig. 2.4.6).

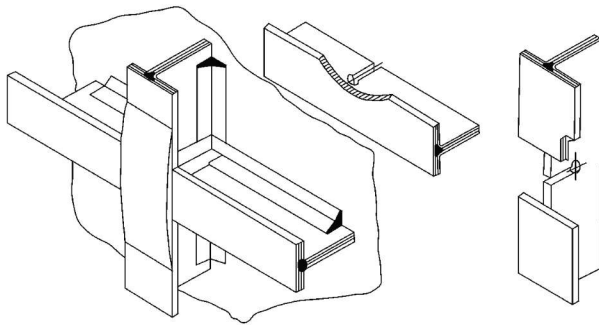

Fig. 2.4.6

Notes: 1. Deep members are jointed by means of an edge cross lap.

2. The length of the outer strap shall not be more than three widths of the flange of longitudinal framing member. A 20 mm overlap in adjacent layers shall be provided. The strap thickness shall be equal to that of the flange of transverse framing member.

**2.4.7** The intersection of a side stringer and a frame shall be made as shown in Figs. 2.3.6-1 and 2.3.6-2 without cutting the frame.

## 2.5 DECKS AND DECK FRAMING

**2.5.1** The upper deck laminate thickness shall be determined from Figs. 2.1.1-1 and 2.1.1-2 depending on the permissible bending moment value given in Table 2.5.1.

**2.5.2** The minimum deck laminate thickness shall be 4 mm.

Table 2.5.1

| Length of ship, m | Spacing, mm | $m_{perm}$ , N·m | Deck stringer width, mm |
|-------------------|-------------|------------------|-------------------------|
| (5)               | (350)       | (0,8)            | (300)                   |
| (7,5)             | (350)       | (1,3)            | (400)                   |
| (10)              | (350)       | (2,0)            | (475)                   |
| 12                | 350         | 2,8              | 575                     |
| 15                | 350/400     | 3,5/4,5          | 650                     |
| 17,5              | 400         | 5,2              | 750                     |
| 20                | 400         | 6,0              | 825                     |
| 22,5              | 400         | 6,7              | 925                     |
| 25                | 400/450     | 7,5/9,5          | 1000                    |
| 27,5              | 450         | 10,3             | 1100                    |
| 30                | 450         | 11,0             | 1200                    |

Notes: 1. Where the spacing differs from the Table value,  $m_{perm}$  shall be modified in proportion to the ratio of  $\left(\frac{\text{actual spacing}}{\text{table spacing}}\right)^2$ .

2. The deck stringer thickness is taken equal to the sheerstrake thickness (refer to Table 2.2.1).

3. For intermediate ship lengths  $m_{perm}$  shall be determined by linear interpolation.

**2.5.3** The thickness and width of a deck stringer shall be determined in accordance with Table 2.5.1.

**2.5.4** The deck is permitted to be constructed of glass-reinforced plastics of the following types:

- I — for hulls from 12(5) to 15 m in length;
- VI — for hulls from 12(5) to 30 m in length;
- VIII — for hulls from 12(10) to 30 m in length.

Decks of ships between (5) and (10) m in length may be constructed of glass-reinforced plastic of type II.

**2.5.5** The reinforcing material shall be laid up in accordance with the requirements of 2.2.4 to 2.2.6.

**2.5.6** Areas, which are subject to intense wear, shall be increased in thickness by means of straps not less than 3 mm thick, unless the deck in these areas has a special protective coating.

**2.5.7** The scantlings of beams are taken in accordance with the requirements of 2.1.2, depending on the section modulus given in Table 2.5.7.

**2.5.8** Deep beams having 5 times the bottom section modulus shall be fitted at every web frame.

**2.5.9** The scantlings of the deck girders are taken according to 2.1.2 depending on the section modulus given in Table 2.5.9.

**2.5.10** Intersection of deck framing members shall be made in accordance with Figs. 2.3.6-1, 2.3.6-2 and 2.4.6.

## 2.6 PILLARS

**2.6.1** The present Rules provide for the fitting of tubular pillars manufactured of aluminium alloys.

Alternative materials may be used for construction of pillars on agreement with the Register.

In any case, the pillar material shall be in compliance with the requirements of Part XIII "Materials".

**2.6.2** The scantlings of pillars of aluminium alloys shall be taken according to Table 2.6.2.

Table 2.5.7

| Span of beam, m | Section modulus, cm <sup>3</sup>     |     |     |                                    |     |     |
|-----------------|--------------------------------------|-----|-----|------------------------------------|-----|-----|
|                 | Closed-box section, with spacing, mm |     |     | T-shaped section, with spacing, mm |     |     |
|                 | 350                                  | 400 | 450 | 350                                | 400 | 450 |
| 1,0             | 16                                   | 18  | 20  | —                                  | —   | —   |
| 1,2             | 24                                   | 27  | 30  | —                                  | —   | —   |
| 1,4             | 33                                   | 38  | 43  | —                                  | —   | —   |
| 1,6             | 43                                   | 49  | 55  | 15                                 | 17  | 19  |
| 1,8             | 52                                   | 59  | 66  | 18                                 | 20  | 22  |
| 2,0             | 65                                   | 74  | 83  | 23                                 | 25  | 27  |
| 2,2             | 80                                   | 90  | 100 | 26                                 | 30  | 34  |
| 2,4             | 98                                   | 110 | 124 | 32                                 | 37  | 42  |

Note. The design span of the beam is measured between the ends of the beam brackets, from the bracket end to the deck girder or between the deck girders, whichever is greater.

Table 2.5.9

| Span of deck girder, m | Section modulus, cm <sup>3</sup> , at supported deck breadth, m |      |      |      |     |
|------------------------|---|------|------|------|-----|
|                        | 1,0   | 1,25 | 1,50 | 1,75 | 2,0 |
| 1,8                    | 95  | 120  | 140  | 165  | 190 |
| 2,0                    | 120   | 150  | 180  | 210  | 240 |
| 2,2                    | 140   | 175  | 210  | 250  | 280 |
| 2,4                    | 170   | 210  | 250  | 300  | 340 |
| 2,6                    | 200   | 250  | 300  | 350  | 400 |
| 2,8                    | 230   | 290  | 345  | 400  | 460 |

Notes: 1. The section moduli are given for a T-shaped section. Where closed-box section is used, the Table section modulus shall be increased by the factor of three.  
2. Deck girder span is the greatest of the deck girder spans measured between two supports (centres of pillars, bulkheads, end hatch beams).

Table 2.6.2

| Supported area $l \times b$ , m <sup>2</sup> | Height of pillar, m |        |        |        |        |        |        |
|--|---------------------|--------|--------|--------|--------|--------|--------|
|  | 1,8                 | 2,0    | 2,2    | 2,4    | 2,6    | 2,8    | 3,0    |
| 1,8  | 85/70               | 85/70  | 85/70  | 85/70  | 85/70  | 85/70  | 95/80  |
| 2,5  | 85/70               | 85/70  | 85/70  | 85/70  | 95/80  | 95/80  | 105/90 |
| 3,0  | 85/70               | 95/80  | 95/80  | 95/80  | 95/80  | 105/90 | 105/90 |
| 4,0  | 85/70               | 95/80  | 95/80  | 105/90 | 105/90 | 110/90 | 110/90 |
| 5,0  | 95/80               | 95/80  | 105/90 | 105/90 | 110/90 | 110/90 | 120/90 |
| 6,0  | 95/80               | 105/90 | 105/90 | 105/90 | 110/90 | 120/90 | 120/90 |

Notes: 1. Shown in the nominator and denominator are the outside and inside tube diameters, in mm, respectively.  
2.  $l$  — distance between the centres of adjacent spans of a deck girder, in m;  $b$  — breadth of deck supported by deck girder, in m.

**2.6.3** The pillars shall be connected to the framing by pillar heels made of aluminium alloys or steel and fastened to the framing by bolts.

## 2.7 BULKHEADS

**2.7.1** The thickness of bulkhead laminates shall be determined from Figs. 2.1.1-1, 2.1.1-2 and 2.1.1-3 depending on the permissible bending moment values given in Table 2.7.1.

Table 2.7.1

| Overall height of bulkhead, m | $m_{perm}$ N·m, with spacing, mm |     |     |     |
|-------------------------------|----------------------------------|-----|-----|-----|
|                               | 300                              | 350 | 400 | 450 |
| 1,25                          | 0,9                              | —   | —   | —   |
| 1,50                          | 1,1                              | 1,5 | —   | —   |
| 1,75                          | 1,3                              | 1,8 | 2,3 | —   |
| 2,00                          | 1,5                              | 2,0 | 2,7 | 3,4 |
| 2,25                          | 1,7                              | 2,3 | 3,0 | 3,8 |
| 2,50                          | 1,9                              | 2,6 | 3,3 | 4,2 |
| 2,75                          | 2,1                              | 2,8 | 3,7 | 4,6 |
| 3,00                          | 2,2                              | 3,1 | 4,0 | 5,1 |
| 3,25                          | 2,4                              | 3,3 | 4,3 | 5,5 |
| 3,50                          | 2,6                              | 3,6 | 4,7 | 5,9 |
| 3,75                          | 2,8                              | 3,8 | 5,0 | 6,3 |
| 4,00                          | 3,0                              | 4,1 | 5,3 | 6,8 |
| 4,25                          | 3,2                              | 4,3 | 5,7 | 7,2 |
| 4,50                          | —                                | 4,6 | 6,0 | 7,6 |
| 4,75                          | —                                | —   | 6,3 | 8,0 |
| 5,00                          | —                                | —   | —   | 8,4 |

Notes: 1.  $m_{perm}$  is given for the bottom strake of the bulkhead panels.  
 2. The bulkhead thickness may be reduced in height, the bulkhead thickness at the upper deck shall not be less than half the bottom strake thickness.  
 3. The width of each strake shall be 0,7...1,0 m.  
 4. For bulkheads of intermediate height  $m_{perm}$  is determined by linear interpolation.

**2.7.2** The minimum plate thickness of laminates for watertight bulkheads shall be 4 mm.

**2.7.3** Bulkhead panels may be manufactured of glass-reinforced plastics type I<sub>2</sub>, V<sub>2</sub> or VII<sub>3</sub>.

**2.7.4** The scantlings of bulkhead stiffeners are taken according to 2.1.2 depending on the section modulus given in Table 2.7.4.

**2.7.5** The maximum span of the stiffeners shall not exceed 3 m. Where the bulkhead height exceeds 3 m, a horizontal girder with a section modulus of not less than 5 times the section modulus of the stiffener shall be fitted.

**2.7.6** Where a horizontal girder is provided, a stiffener of the same section modulus as the horizontal girder shall be fitted at the centre line.

**2.7.7** The design of openings in the bulkheads shall comply with the requirements of 2.10.

**2.7.8** The longitudinals shall not be cut at bulkheads. The slots in the bulkheads for the longitudinals shall be 3 to 4 mm higher and wider than the longitudinals proper and after the installation of bulkheads shall be filled with glass rovings and covered with not less than 3 layers of glass fabric.

**2.7.9** The horizontal girders of bulkheads shall be fitted in one plane with side stringers and interconnected by means of brackets, which arm length shall be equal to the web depth of the side stringer.

**2.7.10** The bulkhead stiffeners supported by longitudinal framing members shall be connected thereto by means of straps and matting-in.

**2.7.11** The bulkhead stiffeners receiving support from the bottom or deck shall be interconnected with the nearest transverse member by means of short longitudinals, which depth shall be equal to the stiffener depth. The connection of these short longitudinals to stiffeners shall be effected in accordance with 2.7.9.

Table 2.7.4

| Span of stiffener, m | Section modulus of bulkhead stiffener, cm <sup>3</sup>                    |     |     |     |   |     |     |     |
|----------------------|---|-----|-----|-----|---|-----|-----|-----|
|                      | Stiffener span from deck to bottom or horizontal girder, with spacing, mm |     |     |     | Stiffener span from horizontal girder to bottom, with spacing, mm |     |     |     |
|                      | 300   | 350 | 400 | 450 | 300   | 350 | 400 | 450 |
| 1,25                 | 15  | 18  | 20  | 23  | 24  | 29  | 33  | 37  |
| 1,50                 | 25  | 29  | 33  | 37  | 30  | 35  | 40  | 45  |
| 1,75                 | 40  | 47  | 54  | 60  | 50  | 59  | 67  | 76  |
| 2,00                 | 55  | 64  | 73  | 92  | 80  | 92  | 105 | 105 |
| 2,25                 | 80  | 93  | 105 | 105 | 95  | 110 | 125 | 140 |
| 2,50                 | 95  | 110 | 125 | 140 | 130   | 150 | 170 | 190 |
| 2,75                 | 130   | 150 | 170 | 190 | 170   | 200 | 225 | 260 |
| 3,00                 | 160   | 187 | 210 | 240 | 225   | 260 | 300 | 335 |

Notes: 1. The section moduli are given for stiffeners of T-shaped section.  
 2. For stiffeners of closed-box section with the face plate reinforced with glass mats the table section modulus shall be increased by the factor of three.

## 2.8 TANKS

**2.8.1** The thickness of the laminates for the tank boundary structures shall be determined from Figs. 2.1.1-1 to 2.1.1-3 depending on the value of permissible bending moment  $m_{perm}$  given in Table 2.7.1. In so doing, the distance up to the top of the air pipe shall be used in lieu of the full height of the bulkhead shown in Table 2.7.1 (refer also to 2.7.2).

**2.8.2** The scantlings of tank framing members shall be determined in accordance with Table 2.8.2.

Table 2.8.2

| Head of water, m | Section modulus of closed-box section, cm <sup>3</sup> , with 400 mm spacing and span, m |      |      |      |
|------------------|--|------|------|------|
|                  | 0,50   | 0,75 | 1,00 | 1,25 |
| 2,00             | 10   | 25   | 50   | 70   |
| 2,50             | 15   | 30   | 60   | 85   |
| 3,00             | 20   | 40   | 70   | 100  |
| 3,50             | 25   | 45   | 80   | 120  |
| 4,00             | 30   | 50   | 90   | 140  |
| 4,50             | 35   | 55   | 100  | 160  |
| 5,00             | 40   | 65   | 110  | 175  |

Notes: 1. In this table scantlings for a closed-box section are given. Material used is glass-reinforced plastic on the basis of glass mats (type I<sub>2</sub>). Where T-shaped section with a flange of glass-reinforced plastic, type III<sub>3</sub>, is used, the section modulus may be reduced by the factor of three.  
2. The section moduli in the Table are given for a 400 mm spacing. For other spacings the section modulus value shall be modified in proportion to the ratio of  $\frac{\text{spacing, mm}}{400}$ .  
3. The design head of water is measured from the midlength of stiffener or from the crown to the air pipe top.  
4. The span of stiffener is measured from the bottom to the crown. The span of beams is measured between the sides or between the side and the collision bulkhead.

**2.8.3** The thickness of the margin plate in way of the double bottom tanks shall be equal to the thickness of shell laminates in this area.

**2.8.4** The sides and tops of tanks may be constructed of glass-reinforced plastics type I<sub>2</sub>, II<sub>2</sub> or V<sub>2</sub>.

**2.8.5** Fuel tanks constructed of glass-reinforced plastics shall be provided with earthing arrangements for discharging static electricity approved by the Register.

**2.8.6** The construction of tank manholes and covers shall ensure the watertightness of the tanks.

The recommended design of a manhole fitted in the crown of tank is shown in Fig. 2.8.6.

**2.8.7** The framing members situated inside the tanks shall be provided with water courses and air holes.

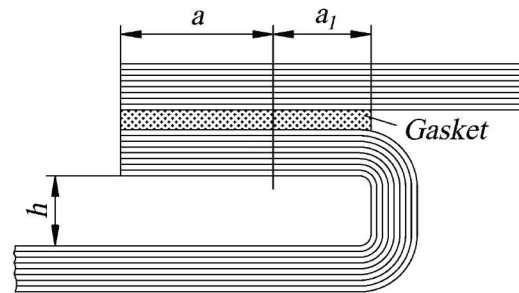

Fig. 2.8.6:

$a$  — minimum distance from the edge to bolts;

$a \geq 3d$  ( $d$  is a diameter of bolt);

$h$  — depth of suit bolt or nut fitting;

$a_1 \geq 1,5d$ .

Note. Bolts shall be spaced not more than  $4d$  a part.

## 2.9 SUPERSTRUCTURES AND DECKHOUSES

**2.9.1** The superstructure outer shell, which is the continuation of the ship's side plating, shall be integral with this plating. The laminate thickness of the superstructure shall be equal to that of the hull sides. The thickness reduction from the sheerstrake to the superstructure sides shall be in accordance with Table 2.2.1.

**2.9.2** The sides of superstructures not extending to the hull sides and deckhouses may be of single-skin or sandwich construction. The material to be used for superstructure and deckhouse sides is glass-reinforced plastic on the basis of glass mats or woven rovings (type I<sub>2</sub> or II<sub>2</sub>). The framing members shall be of glass-reinforced plastic, type I<sub>2</sub>.

**2.9.3** The double-skin construction of superstructures and deckhouse is subject to special consideration by the Register.

**2.9.4** In sandwich constructions the thickness of the foam plastic core shall be 30 to 50 mm. The average density of the foam plastic core for superstructure sides shall not be less than 100 and more than 200 kg/m<sup>3</sup>.

**2.9.5** The laminate thicknesses for the end bulkheads of superstructures as well as for all outer ends and sides of deckhouses shall be taken according to Table 2.9.5-1 for single-skin construction and Table 2.9.5-2 for sandwich construction.

**2.9.6** The scantlings of stiffeners of the superstructure and deckhouse ends and sides are determined from Table 2.9.6-1 for single-skin construction and Table 2.9.6-2 for sandwich construction.

**2.9.7** The deck laminate thickness and the scantlings of the deck framing of superstructures and deckhouses are taken in accordance with the requirements of 2.5 and 2.6.

Table 2.9.5-1  
Ends and sides of superstructures and deckhouses of single-skin construction, spacing 400 mm

| Length of ship, m | Plate thickness, mm |
|-------------------|---------------------|
| (5)               | (4)                 |
| (10)              | (6)                 |
| 15                | 8                   |
| 20                | 10                  |
| 25                | 10                  |
| 30                | 10                  |

Notes: 1. For other spacings the thickness shall be modified in proportion to the ratio of spacing, mm/400, but it shall not be less than 4 mm.  
2. Material used is glass-reinforced plastic on the basis of glass mat (type I<sub>2</sub>).  
3. For intermediate ship lengths the thickness shall be determined by linear interpolation.

Table 2.9.5-2  
Ends and sides of superstructures and deckhouses of sandwich construction with core thickness 30 to 50 mm, spacing 800 mm

| Length of ship, m | Laminate thickness, mm |       |
|-------------------|------------------------|-------|
|                   | outer                  | inner |
| (5)               | (3)                    | (2,5) |
| (10)              | (4)                    | (3)   |
| 15                | 7                      | 3,5   |
| 20                | 8                      | 4     |
| 25                | 8                      | 4     |
| 30                | 8                      | 4     |

Note. For other spacings the outer laminate thickness shall be modified in proportion to the ratio of spacing, mm/800 but it shall not be less than 3 mm.

Table 2.9.6-1  
Stiffeners in superstructures and deckhouses of single-skin construction, spacing 400 mm

| Span of stiffener, m | Modulus of closed-box section, cm <sup>3</sup> | Span of stiffener, m | Modulus of closed-box section, cm <sup>3</sup> |
|----------------------|--|----------------------|--|
| 1,0                  | 18   | 1,8                  | 53   |
| 1,2                  | 25   | 2,0                  | 74   |
| 1,4                  | 38   | 2,2                  | 90   |
| 1,6                  | 49   | 2,4                  | 105  |

Notes: 1. For other spacings the section modulus shall be modified in proportion to the ratio of  $\frac{\text{spacing, mm}}{400}$ .  
2. For intermediate values of stiffener spans the section modulus shall be determined by linear interpolation.

Table 2.9.6-2  
Stiffeners in superstructures and deckhouses of sandwich construction, spacing 800 mm

| Span of stiffener, m | Section modulus of closed-box section, cm <sup>3</sup> | Span of stiffener, m | Section modulus of closed-box section, cm <sup>3</sup> |
|----------------------|--|----------------------|--|
| 1,0                  | 37   | 1,8                  | 120  |
| 1,2                  | 52   | 2,0                  | 150  |
| 1,4                  | 75   | 2,2                  | 194  |
| 1,6                  | 98   | 2,4                  | 215  |

Notes: 1. For other spacings the section modulus shall be modified in proportion to the ratio of  $\frac{\text{spacing, mm}}{800}$ .  
2. The spacing for superstructure sides shall be brought in compliance with the beam spacing of the superstructure deck.  
3. For intermediate values of stiffener spans the section modulus is determined by linear interpolation.

2.10 OPENINGS IN STRUCTURES

2.10.1 Round openings cut in the shell, deck and watertight bulkheads with a diameter less than 150 mm are permitted not to be reinforced.

2.10.2 Round openings cut in the shell with a diameter of 150 mm and over shall be reinforced with glass fabric of satin weave or woven rovings in accordance with Fig. 2.10.2.

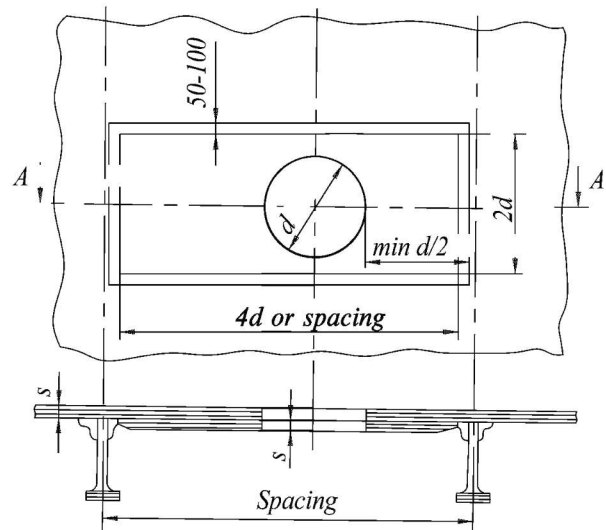

Fig. 2.10.2

Notes: 1. Reinforcing shall be made only with glass fabric whose warp is oriented along the hull.

2. The thickness of the strap shall be equal to that of the structure. If the position of the openings is specified beforehand, the strap is moulded into the basic layers of the laminate, otherwise it shall be matted onto the inner face of the laminate between the frames, within one spacing as shown in the Figure.

3. Openings are not permitted to be positioned closer than  $d/2$  to the frame.

The reinforcements of openings having other shapes are subject to special consideration by the Register.

2.10.3 Round openings cut in decks with a diameter of 150 mm and over as well as rectangular openings of any diameter shall be reinforced with glass fabric of satin weave or woven rovings.

The recommended reinforcement of openings is shown in Figs. 2.10.3-1 and 2.10.3-2.

2.10.4 Lightning holes are not permitted to be made in the webs of framing members.

2.10.5 Openings cut in the framing member webs for the passage of cables, pipes, etc. and having diameters more than 1/3 of the web depth shall be strengthened with straps.

2.10.6 Dimensions of openings and the structure of closures in the outer shell and watertight bulkheads of ships, which subdivision is regulated by Part V "Subdivision", shall be specially agreed with the Register.

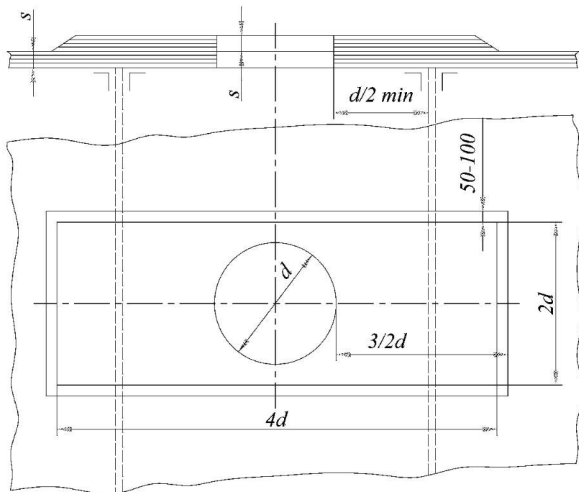

Fig. 2.10.3-1

Notes: 1. Reinforcing shall be made only with glass fabric, which warp is oriented along the hull.

2. The thickness of the strap shall be equal to that of the structure. The strap is matted into the basic layers of the laminate of the position of the openings is known beforehand or moulded onto the upper surface of the deck.

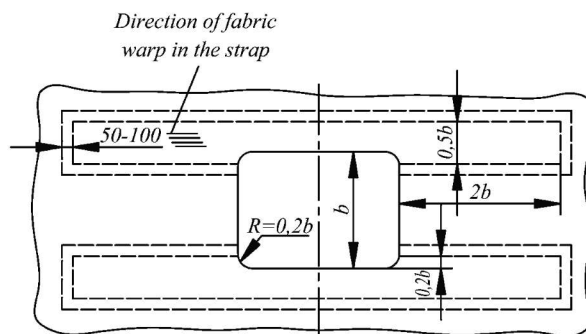

Fig. 2.10.3-2

Notes: 1. Reinforcing shall be made only with glass fabric.  
2. The fabric layers forming the strap shall be laid between the reinforcement layers of the deck laminate.  
3. The total thickness of the reinforcing fabric layers shall be equal to the deck laminate thickness.

## 2.11 BULWARK

**2.11.1** The bulwark thickness shall be equal to half the thickness of the side laminate but not less than 4 mm.

**2.11.2** The bulwark stays shall be fitted at alternate beams.

**2.11.3** In ships over 15 m in length the bulwark laminate shall not form an integral part of the side laminate, and its sectional area shall not be taken into account when the hull section modulus is determined.

**2.11.4** The structure of bulwarks in ships, which can moor at sea, shall be specially considered by the Register.

## 2.12 ENGINE SEATINGS

**2.12.1** Side girders shall be used as far as possible as bearers of the main engine seatings. Where this is not feasible, additional bottom longitudinals shall be fitted with the web thickness equal to that of the side girder.

**2.12.2** The engine seating girders shall extend forward and aft beyond the machinery space bulkheads for at least three spacings and be tapered at the end of the third spacing to floor depth.

**2.12.3** The seating girders shall be reliably connected with transverse brackets fitted at every frame.

**2.12.4** Seatings are permitted to be built of steel and aluminium alloys on special agreement with the Register.

**2.12.5** The fastening of the engine bed flanges may be made by metal flats moulded into the flanges of the girders by fitting of metal angle sections bolted to the girder top edge or by other means approved by the Register.

## 2.13 STEMS, STERNFRAMES, PROPELLER SHAFT BRACKETS AND BILGE KEELS

**2.13.1** Stems may be moulded of glass-reinforced plastic or may be of composite structure with the use of metal.

**2.13.2** For the reinforcing of the stem laminate glass fabrics, woven rovings and glass-fibre bundless (rovings) are used.

The use of glass mats is not permitted.

**2.13.3** Metal parts of the stem may be of aluminium alloys or of steel reliably protected by corrosion-resistant coating.

As a rule, they shall be moulded into the stem.

**2.13.4** The stem moulded of glass-reinforced plastic shall be shaped as a rectangle with the width  $b$  and length  $l$  calculated by the formulae, in mm:

$$b = 1,5L + 30; \quad (2.13.4)$$

$$l = 2,5b$$

where  $L$  = ship's length, m.

The thickness of the stem laminate reinforced with glass fabrics (types II, III or IV) shall be 1,5 times the sheerstrake thickness. The space inside the stem shall be filled with plastic reinforced with glass-fibre bundles, which shall be directed along the stem.

**2.13.5** In the case of composite stems the width  $b_1$  of the aluminium alloy core, length  $l_1$  and total width  $b_2$  of the stem are calculated by the formulae, in mm:

$$b_1 = 0,4L + 10;$$

$$b_2 = b_1 + 2s; \quad (2.13.5)$$

$$l_1 = 2,5b_2$$

where  $L$  = ship's length, m;  
 $s$  = stem laminate thickness determined as specified in 2.13.4.

**2.13.6** The steel core width may be equal to 3/4 of the aluminium core width (refer to 2.13.5). The core length is calculated in accordance with 2.13.5.

**2.13.7** The sternframe, if fitted, may be metal or composite (glass-reinforced plastic with metal core).

The scantlings and structure of the sternframe are subject to special consideration by the Register.

**2.13.8** The shaft brackets shall be as required in 2.10.4.5, Part II "Hull". The flanges of the brackets shall be attached to the hull by means of bolting. Straps of glass-reinforced plastic having a thickness equal to twice the shell thickness and fitted on the

reverse side in way of bracket attachment as well as stiffening for framing members, which shall be agreed with the Register, shall be provided in this area.

**2.13.9** Bilge keels, if fitted, shall be of glass-reinforced plastic of type II. The attachment of bilge keels to the hull shall be effected by means of matting-in double angles (without using bolts), which shall be fitted on both sides of the keel laminate. The thickness of the matting-in double angles shall be equal to that of the keel laminate. The structural design of bilge keels shall be such that no damage would be caused to the shell in case of bilge keel loss.

#### 2.14 CASINGS OF ENGINE AND BOILER ROOMS, HATCH AND FAN COAMINGS

**2.14.1** The structure and scantlings of engine and boiler room casings, hatch and fan coamings are subject to special consideration by the Register.

### 3 STRENGTHENING IN SHIPS FOR NAVIGATION IN ICE

#### 3.1 GENERAL

**3.1.1** Ice class ships with glass-reinforced plastic hull over 12 m in length in accordance with the requirements stated below obtain the mark **Ice2** in their class notation.

The definitions of ice class (marks) are given in 2.2.3, Part I "Classification".

#### 3.2 ICE STRENGTHENING FOR SHIPS OF ICE CLASS ICE2

**3.2.1** An ice belt shall be provided on the shells, the upper edge of which shall be extended 0,5 m above the winter load waterline, while the lower edge shall be 0,5 m below the waterline in the ballast condition.

The ice belt shall extend from the stem to the transom or sternframe over the entire length of the ship.

**3.2.2** The ice belt in ships from 12 to 30 m in length is formed as a strap, which is moulded of glass-reinforced plastics of types III<sub>1</sub>, IV<sub>1</sub> and II<sub>1</sub> matted layer by layer onto the finished hull.

**3.2.3** Prior to laying up the strap the shell surface in the area shall be thoroughly cleaned.

**3.2.4** The thickness of the ice belt strap shall not be less than 1/3 of the shell thickness in the area. The thickness of the strap shall be tapered over a width of 100 mm upwards from the lower edge and 100 mm downwards from the upper edge of the ice belt.

**3.2.5** The scheme of the strap reinforcement in way of the stem shall preclude the tear-off of the fore edge of the ice belt. To this end, a strap of glass-reinforced plastic of type II, III or IV as thick as the sheerstrake shall be fitted along the stem in way of the ice belt. The strap shall overlap the ice belt for one spacing. The strap thickness shall be tapered in the aft direction beginning from the spacing middle.

**3.2.6** The use of synthetic materials for the ice belt is permitted on special agreement with the Register.

**3.2.7** For ships under 12 m in length, the scantlings of the ice belt may be reduced on agreement with the Register.

**3.2.8** For ships of 15 m and over in length a side stringer is required to be fitted at the level of the winter load waterline.

**3.2.9** For ships of 15 m and over in length the spacing shall be reduced by 50 mm as compared to that given in 1.6. The section modulus of frames is then adopted in accordance with 2.4 without regard to the spacing reduction.

## 4 LIFEBOAT HULL

### 4.1 GENERAL

**4.1.1** The determination of scantlings and selection of the required type of glass-reinforced plastic shall be made in accordance with Section 2 unless special requirements are given in the present Section.

**4.1.2** The scantlings are permitted to be determined by calculation in accordance with Appendix 3.

### 4.2 SHELL

**4.2.1** For hulls of lifeboats the following types of glass-reinforced plastics are permitted to be used:

for hulls up to 8 m in length — plastics based on glass mats or woven rovings of parallel lay-up with one or two layers of glass mat or woven rovings on the faces to preclude the passage of water into the laminate and impart necessary smoothness to the laminate surface (types I and II). The mass of 1 m<sup>2</sup> of glass mat and of woven roving fabric shall not exceed 0,8 kg and 0,7 kg, respectively;

for hulls over 8 m in length — plastics based on glass mats (type I) or woven rovings of parallel and diagonal lay-up with one or two protective layers of glass mats (type VII) on the faces or a combination of woven rovings of parallel lay-up (50 per cent of the laminate thickness) and glass mats (50 per cent of the laminate thickness) of type V. In any case, at least one layer of glass mats or glass fabric shall be laid on the laminate faces.

**4.2.2** Seams and butts of strips of reinforcing material in members with parallel and diagonal reinforcement shall be formed as butts without overlap for any thickness exceeding 6 mm; for thicknesses between 2 and 6 mm, the overlap shall be at least 50 mm.

The butts and seams in each adjacent layer shall be spaced not closer than 100 mm apart. Butts and seams are permitted to be coincident in one section after 6 layers at least.

**4.2.3** The minimum thickness of shell laminate in the case of single-skin construction shall be 4 mm, the outer and inner skins in the case of sandwich construction shall be 3 mm and 2 mm, respectively.

**4.2.4** The thickness of shell laminate in the case of single-skin construction shall be determined from Figs. 2.1.1-1, 2.1.1-2 and 2.1.1-3 depending on the value of  $m_{perm}$  given in Table 4.2.4 and according to the plastic type chosen and the glass content by mass.

Table 4.2.4

Shell laminate (single-skin construction)

| Length of lifeboat, m | Spacing, mm | $m_{perm}$ , N·m |      |
|-----------------------|-------------|------------------|------|
|                       |             | bottom           | side |
| 4,5                   | 300         | 1,2              | 0,8  |
| 6,5                   | 350         | 1,8              | 1,3  |
| 8,0                   | 400         | 2,3              | 1,7  |
| 10,0                  | 450         | 2,8              | 2,1  |
| 12,0                  | 450         | 3,2              | 1,4  |

Notes: 1. For intermediate hull lengths  $m_{perm}$  is determined by linear interpolation.

2. For conversion to the spacing other than given in this Table, refer to Table 2.2.1.

3. The thickness adopted for the bottom shell shall be maintained from the keel to a level not less than 1/3 of the side depth.

**4.2.5** The laminate thickness of air cases of glass-reinforced plastic of type I or II shall be from 2 mm (for a length of 4,5 m) to 4 mm (for a length of 12 m).

For air cases serving at the same time as seats the laminate thickness shall be increased by 3 mm.

**4.2.6** For double-skin and sandwich constructions, the laminate thickness of the outer skin shall be 75 per cent and the thickness of the inner skin — 50 per cent of the thickness of the single-skin construction, respectively (refer to Table 4.2.4).

**4.2.7** Special care shall be given to the quality of the lifeboat shell coating with decorative polyester binder.

**4.2.8** Any necessary increase in the hull laminate thickness shall be formed by additional reinforcing material layers, which shall be uniformly distributed between the basic layers and be alternate with same.

**4.2.9** Connection of the hull halves along CL is permitted only in well-founded cases.

**4.2.10** Connection of the lifeboat side to the deck or gunwale shall be effected by means of bolts or matting-in angles of glass-reinforced plastics of type III or IV, the thickness of each matting-in angle being not less than 0,7 times the side thickness, and the flange width being 80 mm + 5 $s_s$ , where  $s_s$  is the thickness of the side shell laminate, in mm.

### 4.3 FRAMING

**4.3.1** The section moduli of frames in a lifeboat of single-skin shell construction shall not be less than stated in Table 4.3.1.

Table 4.3.1

| Length of lifeboat, m | Spacing, mm | Section modulus, cm <sup>3</sup> |
|-----------------------|-------------|----------------------------------|
| 4,5                   | 300         | 28                               |
| 6,5                   | 350         | 42                               |
| 8,0                   | 400         | 56                               |
| 10,0                  | 450         | 70                               |
| 12,0                  | 450         | 77                               |

Notes: 1. The section moduli are given for closed box section frames moulded of glass-reinforced plastic, type I<sub>2</sub>. For tee-shaped frames with flanges of glass-reinforced plastic of type II<sub>3</sub> and webs of glass-reinforced plastic of type I<sub>2</sub> the section moduli may be reduced by the factor of three.  
2. Where the spacing differs from the Table value, the section modulus shall be modified in proportion to the ratio of the actual spacing to the Table spacing.

**4.3.2** In the case of double-skin construction, the section modulus of the frame enclosed between the outer and inner skin in conjunction with the skin strips as wide as the spacing shall not be less than that given in Table 4.3.1.

**4.3.3** In the case of sandwich construction the necessity of fitting transverse framing and the scantlings of same are subject to special consideration by the Register.

**4.3.4** The scantlings of the keel girder shall be chosen in accordance with Fig. 4.3.4.

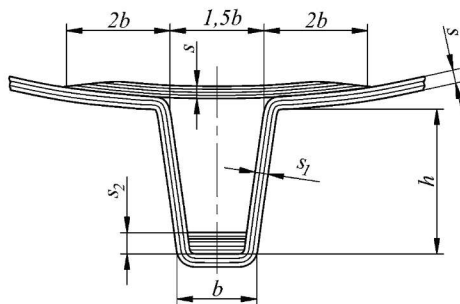

Fig. 4.3.4

| Length of lifeboat, m | Scantlings of section, mm |           |     |       |       |
|-----------------------|---------------------------|-----------|-----|-------|-------|
|                       | depth $h$                 | width $b$ | $s$ | $s_1$ | $s_2$ |
| 4,5                   | 70                        | 60        | 4,5 | 9,0   | 15,0  |
|                       | 90                        | 80        | 5,0 | 10,0  | 20,0  |
| 6,5                   | 110                       | 80        | 5,5 | 10,0  | 20,0  |
|                       | 140                       | 100       | 7,0 | 12,0  | 25,0  |
| 8,0                   | 135                       | 100       | 6,0 | 12,0  | 24,0  |
|                       | 180                       | 120       | 8,0 | 14,0  | 30,0  |
| 10,0                  | 190                       | 120       | 7,0 | 14,0  | 30,0  |
|                       | 240                       | 140       | 9,0 | 16,0  | 35,0  |
| 12,0                  | 220                       | 130       | 8,0 | 16,0  | 35,0  |
|                       | 260                       | 150       | 9,0 | 18,0  | 40,0  |

Notes: 1. Given in the numerator are the scantlings for glass-reinforced plastics, types II, V and VII, in the denominator — those for type I.

2. The density of laying up the reinforcing glass fabric (percentage content of glass by mass) is in compliance with the second lines of Tables 1 to 6, Appendix 2.

3. Thickness  $s_2$  is obtained by addition of rovings to be laid inside the keel.

**4.3.5** The recommended design of the keel is shown in Fig. 4.3.5.

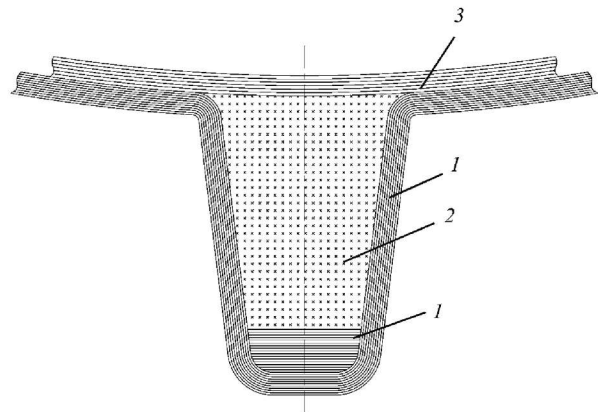

Fig. 4.3.5:

1 — glass-reinforced plastic;

2 — foam plastic;

3 — glass-reinforced plastic laid up inside the keel

**4.3.6** In lifeboats between 8 and 12 m in length keelsons shall be fitted (one on each side). The section moduli of the keelsons shall be found in Table 4.3.6.

Table 4.3.6

| Length of lifeboat, m | Section modulus, cm <sup>3</sup> |
|-----------------------|----------------------------------|
| 4,5                   | —                                |
| 6,5                   | —                                |
| 8,0                   | 150                              |
| 10,0                  | 400                              |
| 12,0                  | 600                              |

Notes: 1. The section moduli of keelsons are given for tee-shaped sections with the face plate of glass-reinforced plastic, type III<sub>3</sub> and the web of type I<sub>2</sub>.

2. For closed-box sections of glass-reinforced plastic, type I<sub>2</sub>, the section modulus shall be increased by the factor of three.

3. Keelson shall be fitted at 0,35 to 0,45 of the lifeboat half-breadth ( $B/2$ ) from CL.

4. Where the lifeboat arrangement requires fitting of two keelsons on each side, the section modulus of each keelson shall not be less than 0,75 of the value given in this Table.

#### 4.4 ATTACHMENT OF LIFTING GEAR AND EQUIPMENT

**4.4.1** The attachment of lifting gear to the lifeboat hull shall ensure the transfer of forces to the hull during the lowering of the lifeboat sustaining possible impact overloads due to a sudden braking of the winch, ship's motion and seaways at ship's sides under any possible conditions of ambient temperature.

**4.4.2** The strength of attachment of each lifting hook to the lifeboat hull shall be checked by a static load equal for each lifting hook to 0,75 times the

mass of the lifeboat when loaded with full complement of persons and equipment, which shall be applied for at least 5 min.

**4.4.3** The structure of the mounts for lifting gear parts shall preclude the creep effect of glass-reinforced plastics.

The operation of lifting gear parts for separation from the lifeboat hull is not permitted.

The recommended design of the mounts is shown in Fig. 4.4.3.

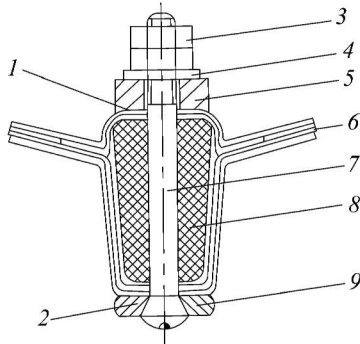

Fig. 4.4.3

1, 2 — tarpaulin gaskets; 3 — nut; 4 — washer; 5 — lifting lug; 6 — deck laminate; 7 — bolt; 8 — insert; 9 — base plate

**4.4.4** The recommended design of the mounts for engine seatings, platforms and pipes is shown in Figs. 4.4.4-1, 4.4.4-2 and 4.4.4-3.

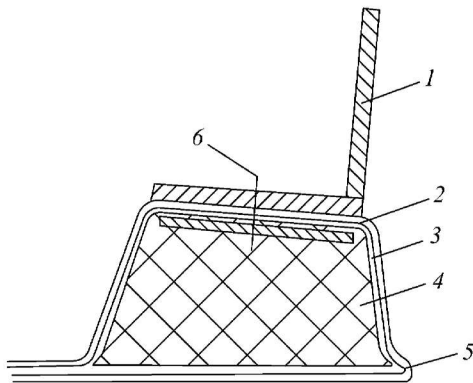

Fig. 4.4.4-1

1 — engine bearer; 2 — steel plate; 3 — girder moulded integral with the inner shell skin; 4 — core (PVC-1); 5 — inner shell skin; 6 — screw

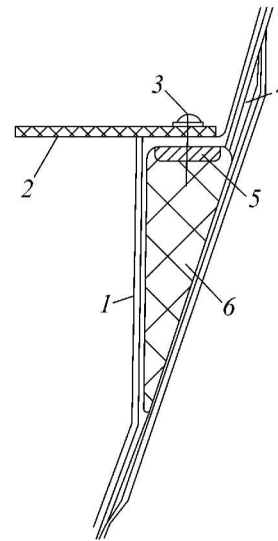

Fig. 4.4.4-2

1 — step moulded integral with the inner shell skin; 2 — platform (thwart); 3 — screw; 4 — inner shell skin; 5 — steel plate; 6 — core (PVC-1)

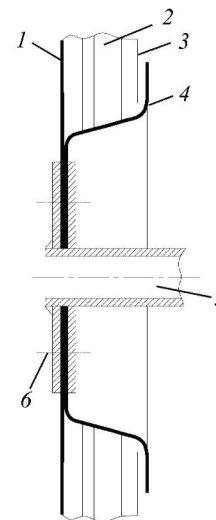

Fig. 4.4.4-3

1 — outer shell skin; 2 — core; 3 — inner shell skin; 4 — glass-reinforced plastic lined hole in the inner shell skin and core; 5 — pipeline; 6 — bolt

## APPENDIX 1

## RECOMMENDED TYPES OF GLASS-REINFORCED PLASTICS

1. The following eight types of glass-reinforced plastics are recommended for use in hull structures of ships and lifeboats:

.1 *type I*: plastic reinforced with glass mats, which may be coated on the outer face or on both faces with one or two layers of glass net or glass fabric to impart better surface smoothness to it (designation *X*);

.2 *type II*: plastic reinforced with woven rovings of plain weave and parallel orientation, i.e. all layers are laid with their warp in one direction (designation *P*);

.3 *type III*: plastic reinforced with glass fabric of satin weave with parallel orientation (designation *T*);

.4 *type IV*: plastic reinforced with glass fabric or glass net of plain weave with parallel orientation (designation *T* or *C*);

.5 *type V*: plastic reinforced both with glass mats and woven rovings of parallel orientation, each amounting to 50 per cent in thickness, the layers of mats and woven rovings being alternately laid through the entire thickness of the laminate;

.6 *type VI*: plastic with the same reinforcement thickness ratio as for type V, but with mats concen-

trated in the middle and woven rovings laid on the outer and inner faces and amounting to 1/4 of the thickness on each side;

.7 *type VII*: plastic with parallel and diagonal reinforcement of woven rovings at angles  $+45^\circ$  and  $-45^\circ$ , which layers, laid parallel to the warp, shall amount to half the laminate thickness, while the diagonal parts plied at  $+45^\circ$  and  $-45^\circ$  to the layers of parallel orientation shall amount to 1/4 of the laminate thickness each, the layers of parallel reinforcement being alternately laid throughout the entire thickness;

.8 *type VIII*: layers arranged diagonally shall occupy the middle portion of the laminate thickness while those of parallel reinforcement shall form the outer and inner faces of the laminate (packet arrangement).

Glass-reinforced plastics, types II, V, VI, VII and VIII shall be overlaid on both faces with one or two layers of glass fabric or glass net.

2. The schemes of reinforcement for the above plastics types are shown in Fig.

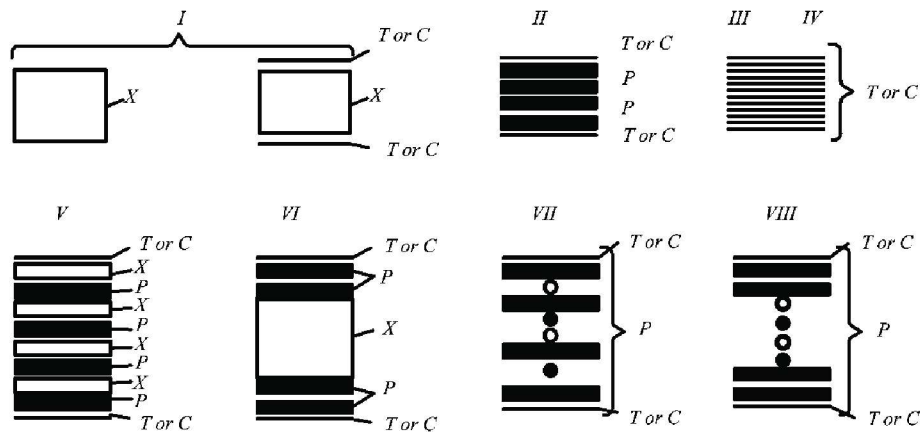

Fig. Schemes of reinforcement. Reinforcing material:

*X* — glass mat, *P* — woven rovings (plain weave), parallel orientation of layers: woven rovings, plied at  $+45^\circ$  or  $-45^\circ$ ; *T* or *C* — glass fabric or glass net, parallel orientation of layers. Types of glass-reinforced plastics (shown in per cent is the fraction of thickness composed by layers of the given reinforcement): type I — *X* 100 %; type II — *P* 100 %; types III and IV — *T* 100 % (or *C* 100%); types V and VI — *X* 50 %, *P* 50 %; types VII and VIII —  $0^\circ$  *P* 50 %,  $+45^\circ$  *P* 25 %,  $-45^\circ$  *P* 25 %

## APPENDIX 2

## PHYSICAL AND MECHANICAL PROPERTIES OF GLASS-REINFORCED PLASTICS

Physical and mechanical properties of glass-reinforced plastics depending on the reinforcement schemes included in Appendix 1 shall be in accordance with the values stated in Tables 1 to 6.

For each type of plastic depending on the fibre glass content in per cent by mass the tables contain respective values of physical and mechanical properties.

The values of physical and mechanical properties such as glass content by volume, average density, shear modulus, Poisson's ratio and shear strength in the laminate plane are determined only during approval tests of a particular type of plastic.

Table 1  
Physical and mechanical properties of glass-reinforced plastics with glass mass as reinforcement and a polyester binder (type I).  
TESTED IN DRY CONDITION AT 20 °C

| Nos | Type           | Glass content, per cent |           | Average density, kg/m <sup>3</sup> | Young's modulus, MPa | Shear modulus in laminate plane, MPa | Poisson's ratio | Tensile strength, MPa | Compression strength, MPa | Shear strength in laminate plane, MPa |
|-----|----------------|-------------------------|-----------|------------------------------------|----------------------|--------------------------------------|-----------------|-----------------------|---------------------------|---------------------------------------|
|     |                | by mass                 | by volume |                                    |                      |                                      |                 |                       |                           |                                       |
| 1   | I <sub>1</sub> | 25                      | 15        | 1,45                               | 0,60·10 <sup>4</sup> | 0,22·10 <sup>4</sup>                 | 0,35            | 80,0                  | 110,0                     | 40,0                                  |
| 2   | I <sub>2</sub> | 30                      | 18        | 1,50                               | 0,70·10 <sup>4</sup> | 0,26·10 <sup>4</sup>                 | 0,35            | 90,0                  | 120,0                     | 50,0                                  |

Notes: 1. Glass content by volume and average density of plastics are given for the average density of glass 2550–2600 kg/m<sup>3</sup> and average density of binder as cured 1200–1250 kg/m<sup>3</sup>.  
2. Young's modulus is given for tension-and-compression.  
3. For thicknesses of 4 mm and less the tensile strength is reduced by 20 per cent against the Table value.

Table 2  
Physical and mechanical properties of glass-reinforced plastics with woven rovings of parallel orientation and a polyester binder (type II). Tested in dry condition at 20 °C

| Nos | Type            | Glass content, per cent |           | Average density, kg/m <sup>3</sup> | Young's modulus, MPa                      | Shear modulus in laminate plane, MPa | Poisson's ratio     | Tensile strength, MPa | Compression strength, MPa | Shear strength in laminate plane, MPa |
|-----|-----------------|-------------------------|-----------|------------------------------------|---|--------------------------------------|---------------------|-----------------------|---------------------------|---------------------------------------|
|     |                 | by mass                 | by volume |                                    |   |                                      |                     |                       |                           |                                       |
| 1   | II <sub>1</sub> | 45                      | 28        | 1600                               | $\frac{1,30 \cdot 10^4}{1,30 \cdot 10^4}$ | 0,21·10 <sup>4</sup>                 | $\frac{0,12}{0,12}$ | $\frac{170,0}{170,0}$ | $\frac{105,0}{105,0}$     | 60,0                                  |
| 2   | II <sub>2</sub> | 50                      | 32        | 1640                               | $\frac{1,50 \cdot 10^4}{1,50 \cdot 10^4}$ | 0,25·10 <sup>4</sup>                 | $\frac{0,12}{0,12}$ | $\frac{200,0}{200,0}$ | $\frac{110,0}{110,0}$     | 70,0                                  |
| 3   | II <sub>3</sub> | 55                      | 37        | 1700                               | $\frac{1,70 \cdot 10^4}{1,70 \cdot 10^4}$ | 0,29·10 <sup>4</sup>                 | $\frac{0,12}{0,12}$ | $\frac{230,0}{230,0}$ | $\frac{115,0}{115,0}$     | 80,0                                  |

Notes: 1. Glass content by volume and average density of plastics are given for the average density of glass 2550–2600 kg/m<sup>3</sup> and average density of binder as cured 1200–1250 kg/m<sup>3</sup>.  
2. Young's modulus is given for tension-and-compression.  
3. Shown in the numerator are the values for the warp direction, in the denominator — for the weft direction.  
4. For woven rovings the ratio of breaking strength in the warp and weft direction is 1:1.

Table 3

Physical and mechanical properties of glass-reinforced plastics with glass fabric of satin weave and parallel orientation, and a polyester binder (type III). Tested in dry condition at 20 °C

| Nos | Type             | Glass content, per cent |           | Average density, kg/m <sup>3</sup> | Young's modulus, MPa                    | Shear modulus in laminate plane, MPa | Poisson's ratio     | Tensile strength, MPa | Compression strength, MPa | Shear strength in laminate plane, MPa |
|-----|------------------|-------------------------|-----------|------------------------------------|---|--------------------------------------|---------------------|-----------------------|---------------------------|---------------------------------------|
|     |                  | by mass                 | by volume |                                    |   |                                      |                     |                       |                           |                                       |
| 1   | III <sub>1</sub> | 45                      | 28        | 1600                               | $\frac{1,7 \cdot 10^4}{1,1 \cdot 10^4}$ | 0,28 · 10 <sup>4</sup>               | $\frac{0,15}{0,10}$ | $\frac{270,0}{170,0}$ | $\frac{200,0}{150,0}$     | 80,0                                  |
| 2   | III <sub>2</sub> | 49                      | 31        | 1640                               | $\frac{1,8 \cdot 10^4}{1,2 \cdot 10^4}$ | 0,10 · 10 <sup>4</sup>               | $\frac{0,15}{0,10}$ | $\frac{290,0}{180,0}$ | $\frac{210,0}{160,0}$     | 85,0                                  |
| 3   | III <sub>3</sub> | 52                      | 34        | 1670                               | $\frac{1,9 \cdot 10^4}{1,3 \cdot 10^4}$ | 0,32 · 10 <sup>4</sup>               | $\frac{0,15}{0,10}$ | $\frac{300,0}{190,0}$ | $\frac{220,0}{170,0}$     | 90,0                                  |

Notes: 1. Glass content by volume and average density of plastics are given for the average density of glass 2550–2600 kg/m<sup>3</sup> and average density of binder as cured 1200–1250 kg/m<sup>3</sup>.

2. Young's modulus is given for tension-and-compression.

3. Shown in the numerator are the values for the warp direction, in the denominator — for the weft direction.

4. For the glass fabric the ratio of the breaking strength in the warp and weft direction is 2:1.

Table 4

Physical and mechanical properties of glass-reinforced plastics with glass net or glass fabric of plain weave and parallel orientation, and a polyester binder (type IV). Tested in dry condition at 20 °C

| Nos | Type            | Glass content, per cent |           | Average density, kg/m <sup>3</sup> | Young's modulus, MPa                    | Shear modulus in laminate plane, MPa | Poisson's ratio     | Tensile strength, MPa | Compression strength, MPa | Shear strength in laminate plane, MPa |
|-----|-----------------|-------------------------|-----------|------------------------------------|---|--------------------------------------|---------------------|-----------------------|---------------------------|---------------------------------------|
|     |                 | by mass                 | by volume |                                    |   |                                      |                     |                       |                           |                                       |
| 1   | IV <sub>1</sub> | 45                      | 28        | 1600                               | $\frac{1,3 \cdot 10^4}{1,3 \cdot 10^4}$ | 0,28 · 10 <sup>4</sup>               | $\frac{0,13}{0,13}$ | $\frac{220,0}{220,0}$ | $\frac{160,0}{160,0}$     | 80,0                                  |
| 2   | IV <sub>2</sub> | 49                      | 31        | 1640                               | $\frac{1,4 \cdot 10^4}{1,4 \cdot 10^4}$ | 0,30 · 10 <sup>4</sup>               | $\frac{0,13}{0,13}$ | $\frac{230,0}{230,0}$ | $\frac{170,0}{170,0}$     | 85,0                                  |
| 3   | IV <sub>3</sub> | 52                      | 34        | 1670                               | $\frac{1,5 \cdot 10^4}{1,5 \cdot 10^4}$ | 0,32 · 10 <sup>4</sup>               | $\frac{0,13}{0,13}$ | $\frac{240,0}{240,0}$ | $\frac{180,0}{180,0}$     | 90,0                                  |

Notes: 1. Glass content by volume and average density of plastics are given for the average density of glass 2550–2600 kg/m<sup>3</sup> and average density of binder as cured 1200–1250 kg/m<sup>3</sup>.

2. Young's modulus is given for tension-and-compression.

3. Shown in the numerator are the values for the warp direction, in the denominator — for the weft direction.

4. For the glass fabric the ratio of the breaking strength in the warp and weft direction is 1:1.

Table 5

Physical and mechanical properties of glass-reinforced plastics with composite reinforcement of 1/2 of the thickness by glass mats and 1/2 of thickness by woven rovings of parallel orientation on the basis of polyester binder (type V and VI). Tested in dry condition at 20 °C

| Nos | Type                              | Glass content, per cent |               |       | Average density, kg/m <sup>3</sup> | Young's modulus, MPa                      | Shear modulus in laminate plane, MPa | Poisson's ratio     | Tensile strength, MPa | Compression strength, MPa | Shear strength in laminate plane, MPa |
|-----|-----------------------------------|-------------------------|---------------|-------|------------------------------------|---|--------------------------------------|---------------------|-----------------------|---------------------------|---------------------------------------|
|     |                                   | Glass mats              | Woven rovings | Glass |                                    |   |                                      |                     |                       |                           |                                       |
| 1   | V <sub>1</sub><br>VI <sub>1</sub> | 25                      | 50            | 37,5  | 1550                               | $\frac{1,05 \cdot 10^4}{1,05 \cdot 10^4}$ | 0,24·10 <sup>4</sup>                 | $\frac{0,21}{0,21}$ | $\frac{135,0}{135,0}$ | $\frac{77,0}{77,0}$       | 55,0                                  |
| 2   | V <sub>2</sub><br>VI <sub>2</sub> | 30                      | 55            | 42,5  | 1600                               | $\frac{1,2 \cdot 10^4}{1,2 \cdot 10^4}$   | 0,28·10 <sup>4</sup>                 | $\frac{0,21}{0,21}$ | $\frac{160,0}{160,0}$ | $\frac{80,0}{80,0}$       | 65,0                                  |

Notes: 1. Average density of plastics is given for the average density of glass 2550–2600 kg/m<sup>3</sup>.  
 2. Young's modulus is given for tension-and-compression.  
 3. Shown in the numerator are the values for the warp direction, in the denominator — for the weft direction.

Table 6

Physical and mechanical properties of glass-reinforced plastics with parallel-and-diagonal reinforcement by woven rovings, one half of which is of parallel orientation and the remainder of diagonal orientation, i.e. 1/4 at +45° and 1/4 at -45° and a polyester binder (types VII and VIII). Tested in dry condition at 20 °C

| Nos | Type                                  | Glass content by mass, per cent | Average density, kg/m <sup>3</sup> | Young's modulus, MPa                    | Shear modulus in laminate plane, MPa | Poisson's ratio     | Tensile strength, MPa | Compression strength, MPa | Shear strength in laminate plane, MPa |
|-----|---------------------------------------|---------------------------------|------------------------------------|---|--------------------------------------|---------------------|-----------------------|---------------------------|---------------------------------------|
| 1   | VII <sub>1</sub><br>VIII <sub>1</sub> | 45                              | 1600                               | $\frac{1,1 \cdot 10^4}{1,1 \cdot 10^4}$ | 0,37·10 <sup>4</sup>                 | $\frac{0,30}{0,30}$ | $\frac{140,0}{140,0}$ | $\frac{80,0}{80,0}$       | 56,0                                  |
| 2   | VII <sub>2</sub><br>VIII <sub>2</sub> | 50                              | 1650                               | $\frac{1,3 \cdot 10^4}{1,3 \cdot 10^4}$ | 0,45·10 <sup>4</sup>                 | $\frac{0,30}{0,30}$ | $\frac{170,0}{170,0}$ | $\frac{95,0}{95,0}$       | 68,0                                  |
| 3   | VII <sub>3</sub><br>VIII <sub>3</sub> | 55                              | 1700                               | $\frac{1,5 \cdot 10^4}{1,5 \cdot 10^4}$ | 0,52·10 <sup>4</sup>                 | $\frac{0,30}{0,30}$ | $\frac{200,0}{200,0}$ | $\frac{110,0}{110,0}$     | 79,0                                  |

Notes: 1. Average density of plastics is given for the average density of glass 2550–2600 kg/m<sup>3</sup> and the average density of binder as cured 1200–1250 kg/m<sup>3</sup>.  
 2. Young's modulus is given for tension-and-compression.  
 3. Shown in the numerator are the values for the warp direction, in the denominator — for the weft direction.  
 4. For the glass fabric the ratio of the breaking strength in the warp and weft direction is 1:1.

## APPENDIX 3

GUIDANCE FOR DETERMINATION OF HULL MEMBER SCANTLINGS OF SHIPS  
AND LIFEBOATS BY CALCULATION

## 1 SHIP'S HULL

1.1 In addition to the table method of the hull scantlings determination as given in this Part of the Rules, this may be done by a calculation method approved by the Register.

1.2 The basic data for recalculation of separate hull members as well as calculation of the longitudinal and local strength of the hull as a whole are given in Tables 1.2-1 — 1.2-3.

Table 1.2-1

| Ship's length <sup>1</sup> , m | Maximum bending moment at general bending, kN·m                              |
|--------------------------------|--|
| 5 — 10                         | 1,66ΔLg  |
| 15 — 30                        | ΔLg<br>(Δ — full load displacement of the ship, t; g=9,81 m/s <sup>2</sup> ) |

<sup>1</sup>For ships from 10 to 15 m in length the bending moment is determined by linear interpolation.

Table 1.2-2

| Type of load   | Design formula or value  |
|--|--------------------------|
| Local load on bottom and side shell                            | $h_p = 10(h_1 + \Delta)$ |
| Local load on the upper deck:                                  |                          |
| forward of the fore peak bulkhead                              | 15                       |
| elsewhere  | 5                        |
| Ditto for ships of restricted area of navigation III:          |                          |
| forward of the fore peak bulkhead                              | 10                       |
| elsewhere  | 4                        |
| Water impact against the bottom, when dropped in an emergency: |                          |
| L = 5 m  | 20                       |
| L = 10 m   | 40                       |

Notes: 1.  $h_1$  — distance from the member under consideration to the upper deck:  $\Delta = 0,5$  m for any region, with the exception of the shell in way of the fore peak;  $\Delta = 1,5$  m for the region forward of the fore peak bulkhead.

2. For ships of intermediate length the load is determined by linear interpolation.

1.3 The permissible stress is taken as a part of design tensile, compression or shear strength. For permissible stress in the case of alternating tension-and-compression and bending, either tensile or compressive stresses shall be taken, whichever are less.

Table 1.2-3

| Type of load  | Permissible stress                        |
|---|---|
| Stresses due to general and local bending:  |   |
| at instantaneous load:  |   |
| for glass-reinforced plastic of type I  | $\sigma = 0,25R_m$<br>$\tau = 0,25\tau_m$ |
| for glass-reinforced plastic of types II — VIII   | $\sigma = 0,30R_m$<br>$\tau = 0,30\tau_m$ |
| at permanent load for all types of glass-reinforced plastics  | $\sigma = 0,10R_m$<br>$\tau = 0,10\tau_m$ |
| at shear in the laminate plane for all types of glass-reinforced plastics   | $\tau = 0,30\tau_m$                       |
| at shear in matting-in connections and at interlaminar shear  | $\tau = 0,60\tau_m$                       |
| Stresses in matting-in connections subject to pull:   |   |
| at instantaneous load   | $\sigma = 2$ MPa                          |
| at permanent load   | $\sigma = 1$ MPa                          |
| Symbols:  |   |
| σ — permissible normal stress;  |   |
| τ — permissible shear stress;   |   |
| $R_m, \tau_m$ — tensile strength and shear strength obtained on dry specimens at $t = 20$ °C (refer to Appendix 2). |   |

1.4 Design values for Young's modulus and shear modulus are taken equal to

$$E_d = 0,6E \text{ and } G_d = 0,6G$$

where  $E$  and  $G$  — Young's modulus and shear modulus determined for dry material at 20 °C (refer to Appendix 2).

1.5 For hull structural components the factor of safety against buckling shall be taken not lower than that given in Table 1.5.

Table 1.5

| Structural component to be calculated     | Safety factor |
|---|---------------|
| Centre girder, side and deck girders      | 3             |
| Plate keel, sheerstrake and deck stringer | 1,5           |

1.6 Permissible deflection values calculated with consideration of shear are taken as follows:

1/400 of length for the hull as a whole;

1/50 of spacing for the shell;

1/100 of span for framing members.

1.7 For the shell and upper deck the reduction coefficient may be used. The moment of inertia with consideration of the reduction coefficient shall then not be less than 95 per cent of the moment of inertia calculated in the first approximation without regard to the reduction coefficient.

## 2 LIFEBOAT HULL

**2.1** It is recommended that recalculations of scantlings of separate structures may, if necessary, be based on the following

**2.1.1** For loads used in checking the longitudinal strength of the lifeboat hull, the bending moments and shearing forces acting on the hull during the lowering of a fully loaded lifeboat suspended from two hooks shall be taken. In this case, the maximum bending moment is determined, in kN·m, by the formula

$$M = 1,25 \cdot 10^{-3} Ql$$

where  $Q$  = mass of fully loaded lifeboat with 50 per cent overloading, kg;  
 $l$  = lifeboat length between hooks, m.

The maximum shearing force value is determined, in kN, by the formula

$$N = 0,005Q.$$

The equivalent static design pressures on the bottom with regard to dynamical loads due to water impact against the hull are given in Table 2.1.1 according to the lifeboat mass.

The design pressure on the side is taken to be 80 per cent of the relevant pressure on the bottom.

**2.1.2** In calculating the longitudinal and local strength of the lifeboat hull the permissible normal stress is taken equal to 0,30 of the tensile or compression strength for glass-reinforced plastics of type II — VIII (whichever is less) and to 0,25 for type I plastics. The permissible shear stress is taken equal to 0,30 of the shear strength in the laminate plane (for all types of glass-reinforced plastics);

Table 2.1.1

| Mass of lifeboat loaded with its full complement of persons and equipment, kg | Design pressure, MPa | Mass of lifeboat loaded with its full complement of persons and equipment, kg | Design pressure, MPa |
|---|----------------------|---|----------------------|
| 1000  | 0,04                 | 8000  | 0,06                 |
| 2000  | 0,04                 | 10000   | 0,07                 |
| 3000  | 0,05                 | 15000   | 0,07                 |
| 5000  | 0,05                 | 20000   | 0,08                 |
| 7000  | 0,06                 |   |                      |

Note. For intermediate mass values the pressure shall be determined by linear interpolation.

**2.1.3** In calculating the longitudinal and local strength the permissible deflections are taken as follows:  
 1/333 of length for the lifeboat hull as a whole;  
 1/50 of spacing for shell and bulkheads;  
 1/100 of span for frames.

The permissible variation in the lifeboat's breadth shall be  $1/333L$ .

For the design values of Young's modulus and shear modulus in calculating deflections and checking buckling strength 0,60 of the corresponding values for dry material in initial state at 20 °C shall be taken;

**2.1.4** The factors of safety against buckling shall not be less than:

- 3 for side girders and keel;
- 1,5 for gunwale;
- 1 for shell.

In this case, the local buckling strength only shall be checked.

**2.2** Testing of finished hulls of lifeboat for strength and rigidity shall be effected in accordance with the requirements of Part II "Life-Saving Appliances" of the Rules for the Equipment of Sea-Going Ships.

Российский морской регистр судоходства  
Правила классификации и постройки морских судов  
Часть XVI  
**Конструкция и прочность корпусов судов и шлюпок из стеклопластика**

Russian Maritime Register of Shipping  
**Rules for the Classification and Construction of Sea-Going Ships**  
**Part XVI**  
**Hull Structure and Strength of Glass-Reinforced Plastic Ships and Boats**

The edition is prepared  
by Russian Maritime Register of Shipping  
8, Dvortsovaya Naberezhnaya,  
191186, St. Petersburg,  
Russian Federation  
[www.rs-class.org/en/](http://www.rs-class.org/en/)