

**RUSSIAN MARITIME REGISTER OF SHIPPING**

---

**RULES**  
**FOR THE CLASSIFICATION**  
**AND CONSTRUCTION**  
**OF SEA-GOING SHIPS**

**PART VIII**  
**SYSTEMS AND PIPING**



Saint-Petersburg  
Edition 2018

Rules for the Classification and Construction of Sea-Going Ships of Russian Maritime Register of Shipping have been approved in accordance with the established approval procedure and come into force on 1 January 2018.

The present twentieth edition of the Rules is based on the 2017 edition taking into account the amendments developed immediately before publication.

The unified requirements, interpretations and recommendations of the International Association of Classification Societies (IACS) and the relevant resolutions of the International Maritime Organization (IMO) have been taken into consideration.

The Rules are published in the following parts:

Part I "Classification";

Part II "Hull";

Part III "Equipment, Arrangements and Outfit";

Part IV "Stability";

Part V "Subdivision";

Part VI "Fire Protection";

Part VII "Machinery Installations";

Part VIII "Systems and Piping";

Part IX "Machinery";

Part X "Boilers, Heat Exchangers and Pressure Vessels";

Part XI "Electrical Equipment";

Part XII "Refrigerating Plants";

Part XIII "Materials";

Part XIV "Welding";

Part XV "Automation";

Part XVI "Hull Structure and Strength of Glass-Reinforced Plastic Ships and Boats";

Part XVII "Distinguishing Marks and Descriptive Notations in the Class Notation Specifying Structural and Operational Particulars of Ships";

Part XVIII "Common Structural Rules for Bulk Carriers and Oil Tankers". The text of the part is identical to that of the IACS Common Structural Rules;

Part XIX "Additional Requirements for Structures of Container Ships and Ships, Dedicated Primarily to Carry their Load in Containers". The text of the Part is identical to IACS UR S11A "Longitudinal Strength Standard for Container Ships" (June 2015) and S34 "Functional Requirements on Load Cases for Strength Assessment of Container Ships by Finite Element Analysis" (May 2015).

Parts I to XVII are published in electronic format and hard copy in Russian and English. In case of discrepancies between the Russian and English versions, the Russian version shall prevail.

Parts XVIII to XIX are published in English and in electronic format only.

*As compared to the 2017 edition, the present edition of the Rules contains the following amendments.*

## **RULES FOR THE CLASSIFICATION AND CONSTRUCTION OF SEA-GOING SHIPS**

### **PART VIII. SYSTEMS AND PIPING**

**1.** Paras: 1.4.6.4.5, 2.1.7, 2.1.8, 2.3.3, 2.3.5, 2.3.5.1, 2.4.3.1, 2.6, 5.1.8, 5.3.3, 6.1.3, 6.1.9, 7.1.1, 8.1.5, 9.3.5, 9.5.5, 9.5.6, 9.6.1, 9.10.1, 9.15.4, 11.1.5, 12.1.9, 12.2.7, 13.12.9, 13.14.2, 14.1.2, 14.1.6, 14.3.3, 15.2.1, 16.1.3, 16.1.5, 16.2.1, 20.6.2;

Note 1 to Table 1.3.2; Notes to Table 1.4.1.1.6; Note 9 to Table 2.3.8: the requirements have been specified to avoid the ambiguous phrase "special consideration".

**2.** Paras 1.4.3.4.7, 2.3.5.2, Note 2 to new Table 2.3.5.2 have been deleted to avoid the ambiguous phrase "special consideration".

**3.** Chapter 1.3: in Table 1.3.2 Note 4 has been amended considering the specified reference.

**4.** Section 2: new para 2.1.10 has been introduced considering IACS UI SC282 (Dec 2016);

para 2.3.5.2 has been deleted subsequent paras have been renumbered accordingly;

para 2.4.5 has been specified considering IACS UR 2.7.4 (Rev.8 Mar 2016);

new Chapter 2.6 "Connection gaskets and insulation materials" has been introduced;

**5.** Chapter 3.3: para 3.3.2.1 has been amended considering IACS resolution MSC.399 (95).

**6.** Chapter 4.3: para 4.3.2.10 has been specified considering the experience of technical supervision.

**7.** Chapter 9.5: in para 9.5.5 the requirements have been specified considering the experience of technical supervision.

**8.** Chapter 10.1: para 10.1.12 has been specified.

**9.** Section 11: new Chapter 11.3 "Systems for reducing NO<sub>x</sub> Emissions" has been introduced considering IACS UR M77.

**10.** Chapter 12.1: paras 12.1.19 and 12.1.20 have been specified.

**11.** Chapter 12.6: para 12.6.1 has been amended considering IMO resolution MSC.392(95).

**12.** Chapter 13.2: para 13.2.4 has been specified.

**13.** Chapter 13.7: new para 13.7.8 has been introduced considering IACS UR M76 (Apr 2016).

**14.** Chapter 14.5: para 14.5.4 has been specified.

**15.** Chapter 15.5: para 15.5.2 has been specified.

**16.** Chapter 15.6: the title of the Chapter has been specified.

**17.** Chapter 16.1: in para 16.1.5 the requirements for starting of the auxiliary engine provisions for air receivers that may be dispensed have been specified.

**18.** Editorial amendments have been made.

# CONTENTS

## PART VIII. SYSTEMS AND PIPING

<b>1</b>	<b>General</b>	<b>7</b>	<b>7.1</b>	<b>Pumps</b>	<b>38</b>
1.1	Application	7	7.2	Piping diameters	39
1.2	Definitions and explanations	7	7.3	Piping laying	40
1.3	Scope of surveys	7	7.4	Drainage of machinery spaces	41
1.4	Protection and insulation of piping	8	7.5	Drainage of tunnels	42
1.5	Welding and non-destructive testing of welds	11	7.6	Drainage of cargo spaces	42
<b>2</b>	<b>Metal piping</b>	<b>13</b>	7.7	Drainage of cargo pump spaces of oil tankers	43
2.1	Material, manufacture and application	13	7.8	Drainage of refrigerated cargo spaces	43
2.2	Radii of pipe bends, heat treatment after bending	14	7.9	Drainage of forward spaces of bulk carriers	44
2.3	Metal pipe wall thickness	14	7.10	Drainage of cofferdams	44
2.4	Pipe joints	16	7.11	Fore and aft peak drainage	44
2.5	Flexible hoses	20	7.12	Drainage of other spaces	44
2.6	Connection gaskets and insulation materials	23	7.13	Drainage of floating dock compartments	45
<b>3</b>	<b>Plastic piping</b>	<b>24</b>	7.14	Drainage of spaces intended for the carriage of dangerous goods	45
3.1	Definitions	24	<b>8</b>	<b>Ballast, heel and trim systems</b>	<b>46</b>
3.2	Scope of application. General requirements	24	8.1	Pumps	46
3.3	Requirements for piping depending on their purpose and location	24	8.2	Piping diameters	46
3.4	Installation requirements	26	8.3	Piping laying	46
3.5	Plastic pipes joints	26	8.4	Ballast system of floating docks	46
3.6	Plastic piping laying	26	8.5	Heel and trim systems	46
3.7	Inspection during the installation	27	8.6	Ballast system of bulk carriers	46
3.8	Testing of piping after installation aboard the ship	27	8.7	Ballast systems for ballast water exchange at sea	47
<b>4</b>	<b>Valves</b>	<b>28</b>	<b>9</b>	<b>Systems special for carriage of cargoes in bulk</b>	<b>49</b>
4.1	Construction, marking, arrangement and installation of valves	28	9.1	Application	49
4.2	Filters	28	9.2	General requirements for piping in cargo area	49
4.3	Sea chests and ice boxes. Bottom and side valves. Openings in shell plating	28	9.3	Cargo oil system	49
4.4	Air pipe automatic closing devices	30	9.4	Cargo pumps	50
<b>5</b>	<b>Piping laying</b>	<b>32</b>	9.5	Bow and aft loading system	50
5.1	Piping laying through watertight and fire-proof divisions	32	9.6	Cargo heating system	51
5.2	Piping laying in tanks	32	9.7	Venting system	51
5.3	Piping laying in cargo holds and other spaces	33	9.8	Purging and gas freeing of cargo tanks	53
5.4	Piping laying in refrigerated cargo spaces	33	9.9	Cargo vapour discharge system	53
5.5	Piping laying in the vicinity of electrical and radio equipment	33	9.10	Ship service systems in cargo area	54
5.6	Piping laying in unattended machinery spaces	34	9.11	Level and overflow control of cargo tanks	55
5.7	Piping laying in ships with twin hulls	34	9.12	Cargo tank washing system	55
5.8	Pipelines with electric heating	34	9.13	Static electricity protection	56
<b>6</b>	<b>Ship's hoses</b>	<b>35</b>	9.14	Monitoring the composition of atmosphere in cargo area	57
6.1	Construction of hoses	35	9.15	Oil recovery system of oil recovery ships	58
6.2	Testing of hoses	36	9.16	Inert gas system (IGS)	58
<b>7</b>	<b>Bilge system</b>	<b>38</b>	<b>10</b>	<b>Air, overflow and sounding piping</b>	<b>64</b>
			10.1	Air pipes	64
			10.2	Overflow pipes	65

10.3	Overflow tanks . . . . .	65	13.11	Use of crude oil or slops as fuel for tanker boilers . . . . .	84
10.4	Sounding arrangements . . . . .	66	13.12	Application of natural gas (methane) as fuel . . . . .	85
<b>11</b>	<b>Exhaust gas system.</b> . . . .	<b>67</b>	13.13	Fuel oil systems for helicopters . . . . .	87
11.1	Exhaust gas piping . . . . .	67	13.14	Liquefied gas system for domestic needs. . . . .	87
11.2	Silencers and spark arresters . . . . .	67	13.15	Fuel oil supply system for galley equipment . . . . .	88
11.3	Systems for reducing NO <sub>x</sub> emissions . . . . .	69	<b>14</b>	<b>Lubricating oil system</b> . . . . .	<b>89</b>
<b>12</b>	<b>Ventilation system</b> . . . . .	<b>69</b>	14.1	Lubricating oil pumps of internal combustion engines, gears and couplings . . . . .	89
12.1	Ventilation ducts, heads and air inlets . . . . .	69	14.2	Lubricating oil supply to internal combustion engines and gears. . . . .	89
12.2	Ventilation systems of cargo ships of 500 gross tonnage and upwards, oil tankers and combination carriers carrying petroleum products with flash point 60 °C and more, passenger ships carrying no more than 36 passengers, special purpose ships carrying no more than 240 persons and berth- connected ships . . . . .	71	14.3	Lubricating oil pumps of steam turbines and gears . . . . .	89
12.3	Ventilation systems of passenger ships carrying more than 36 passengers and special purpose ships carrying more than 240 persons. . . . .	72	14.4	Lubricating oil supply to steam turbines and gears . . . . .	90
12.4	Ventilation systems of oil tankers and combination carriers carrying crude oil and petroleum products with flash point 60 °C and below . . . . .	73	14.5	Lubricating oil tanks . . . . .	90
12.5	Ventilation of machinery spaces and tunnels . . . . .	74	14.6	Arrangements for collection of leakage lubricating oil . . . . .	90
12.6	Ventilation of special category spaces, cargo spaces intended for the carriage of motor vehicles with fuel in their tanks and closed ro-ro cargo spaces. . . . .	75	14.7	Lubricating oil supply to gas turbines . . . . .	91
12.7	Ventilation of cargo spaces adapted for the carriage of dangerous goods . . . . .	76	<b>15</b>	<b>Water cooling system</b> . . . . .	<b>92</b>
12.8	Ventilation of refrigerated cargo spaces . . . . .	77	15.1	Pumps . . . . .	92
12.9	Ventilation of fire extinguishing stations . . . . .	77	15.2	Piping laying. . . . .	92
12.10	Ventilation of accumulator battery rooms and boxes. . . . .	77	15.3	Cooling water filters . . . . .	93
12.11	Ventilation of hangars for helicopters. . . . .	78	15.4	Cooling of internal combustion engines . . . . .	93
12.12	Ventilation of spaces in oil recovery ships . . . . .	78	15.5	Cooling of gas turbine installations . . . . .	93
12.13	Ventilation of spaces intended for inert gas equipment . . . . .	78	15.6	Sea-water cooling systems . . . . .	93
<b>13</b>	<b>Fuel oil system</b> . . . . .	<b>79</b>	<b>16</b>	<b>Compressed air system.</b> . . . .	<b>94</b>
13.1	Pumps . . . . .	79	16.1	Number and capacity of starting air receivers . . . . .	94
13.2	Piping laying . . . . .	79	16.2	Compressors . . . . .	94
13.3	Heating arrangements of fuel oil . . . . .	80	16.3	Piping laying. . . . .	95
13.4	Drainage arrangements of fuel oil tanks . . . . .	80	<b>17</b>	<b>Feed water system</b> . . . . .	<b>96</b>
13.5	Arrangements for collection of leakage fuel . . . . .	80	17.1	Pumps . . . . .	96
13.6	Filling of storage tanks . . . . .	81	17.2	Piping laying. . . . .	96
13.7	Fuel oil tanks . . . . .	81	17.3	Tanks . . . . .	96
13.8	Fuel oil supply to internal combustion engines . . . . .	82	<b>18</b>	<b>Steam and blow-off systems</b> . . . . .	<b>97</b>
13.9	Fuel oil supply to boilers . . . . .	83	18.1	Piping laying. . . . .	97
13.10	Fuel oil supply to gas turbines . . . . .	84	18.2	Blow-off arrangements of steam lines . . . . .	97
			18.3	Calculation of steam pipes for thermal expansion . . . . .	97
			<b>19</b>	<b>Condenser installations.</b> . . . .	<b>99</b>
			19.1	General . . . . .	99
			19.2	Pumps . . . . .	99
			19.3	Piping laying. . . . .	99
			19.4	Instrumentation. . . . .	99
			<b>20</b>	<b>Thermal liquid systems.</b> . . . .	<b>100</b>
			20.1	Definitions . . . . .	100
			20.2	Requirements for thermal liquid. . . . .	100
			20.3	Thermal liquid circulation system . . . . .	100
			20.4	Expansion tank. . . . .	100
			20.5	Storage and drain tanks . . . . .	101
			20.6	Piping and valves. . . . .	101
			20.7	Air pipes and sounding arrangements . . . . .	101

---

20.8 Arrangements for collecting of thermal liquid leakages . . . . .	101	21.2 Hydraulic tests of piping . . . . .	103
20.9 Thermal liquid boilers . . . . .	101	21.3 Testing of devices to prevent the passage of flame into cargo tanks in oil tankers. . . . .	103
20.10 Insulation . . . . .	101	21.4 Testing of air pipe automatic closing devices. . . . .	104
20.11 Heating of liquid cargoes . . . . .	102	21.5 Testing of plastic pipes . . . . .	104
20.12 Thermal liquid system piping testing . . . . .	102		
<b>21 Tests . . . . .</b>	<b>103</b>		
21.1 Hydraulic tests of valves. . . . .	103		

# PART VIII. SYSTEMS AND PIPING

---

## 1 GENERAL

### 1.1 APPLICATION

**1.1.1** The requirements of the present Part of the Rules apply to the following pumping and piping arrangements used in ships:

- .1** bilge and drain;
- .2** ballast, heel and trim;
- .3** special systems of tankers and combination carriers;
- .4** liquefied gas;
- .5** toxic media;
- .6** steam and blow-down pipelines;
- .7** feed water and condensate;
- .8** fuel oil;
- .9** lubricating oil;
- .10** water cooling;
- .11** compressed air;
- .12** air, venting, overflow and sounding pipes;
- .13** exhaust gas;
- .14** ventilation;
- .15** open-ended steam pipes from safety valves;
- .16** cleaning and washing of tanks;
- .17** hydraulic drives;
- .18** containing organic coolants.

Special requirements for systems other than stated above are set out in the relevant Parts of the Rules.

Pumping and piping of berth-connected ships shall comply with the requirements of the present Part in so much as applicable and sufficient unless expressly provided otherwise below.

The requirements for systems of polar class ships (refer to 2.2.3.1, Part I "Classification") are set forth in Section 1, Part XVII "Distinguishing Marks and Descriptive Notations in the Class Notation Specifying Structural and Operational Particulars of Ships".

**1.1.2** The fuel oil used in ships shall comply with the requirements of 1.1.2, Part VII "Machinery Installations".

**1.1.3** Machinery and other elements of the systems indicated in 1.1.1 shall remain operative under environmental conditions set out in 2.3, Part VII "Machinery Installations".

**1.1.4** Pumps, fans, compressors and their electric drives used in systems covered by the requirements of the present Part shall also comply with the requirements of Part IX "Machinery" and Part XI "Electrical Equipment".

Control and monitoring devices of piping systems shall comply with the requirements of Part XV "Automation".

Heat exchangers and pressure vessels used in ships systems shall comply with the requirements of Part X "Boilers, Heat Exchangers and Pressure Vessels".

### 1.2 DEFINITIONS AND EXPLANATIONS

**1.2.1** In the present Part the following definitions have been adopted.

**V a l v e s** are stop, regulating and safety devices, intended for motion control, consumption distribution and regulation and other parameters of the conveying medium by means of entire or partial opening or closing of flow section.

**B o t t o m a n d s i d e v a l v e s** are stop valves installed in shell plating of the ship or in sea chests and ice boxes and intended to close openings in shell plating.

**K e e l c o o l e r** is a sea cooler representing a system of tight ducts and pipes mounted under the hull through which engine cooling water is pumped to reduce the temperature.

**P i p e l i n e f i r e r e s i s t a n c e** is the ability of pipeline to maintain strength and functional properties within the set period of time at flame exposure.

**B o x c o o l e r** is a sea cooler representing a heat exchanger where the cooled medium is pumped through cooling pipespaced in special enclosures with side shell openings to provide seawater natural circulation.

**S y s t e m** is a combination of pipelines, machinery, apparatus, devices, appliances and reservoirs, intended for performance of certain functions providing ship's operation.

**P i p e l i n e** is a combination of pipes, valves, fittings, pipe joints, any internal and external linings, insulation coatings, fastening elements and components for protection of pipes, intended for conveying of liquid, gaseous and compound media, as well as for transmission of pressure and sound waves.

**E s s e n t i a l p i p e l i n e** is a pipeline, which damage may result in a combustible medium spillage in the machinery spaces, flooding, toxic media leakage, failure of system ensuring the operation of main and auxiliary engines, loss of run or control.

**P i p e l i n e s f o r m e d c o m p o n e n t s ( f i t t i n g s )** are bends, t-pieces, bulkhead and deck penetrations and other elements of pipelines, intended for pipelines branching, changing of conveying medium direction and ensuring of hull structures tightness.

### 1.3 SCOPE OF SURVEYS

**1.3.1** General provisions relating to classification procedure, surveys during construction and in service, as well as requirements for technical documentation submitted to the Register for considera-

tion and approval, are set forth in General Regulations for the Classification and Other Activity and in Part I "Classification".

1.3.2 Proceeding from the type and characteristics of the conveyed medium pipes are subdivided into three classes as indicated in Fig. 1.3.2 and Table 1.3.2. Test categories, types of joints, welding procedure and heat treatment are determined proceeding from the pipe class.

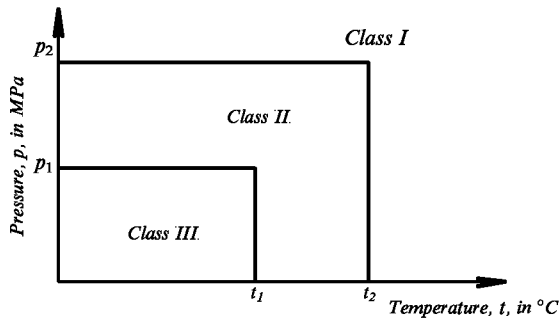

Fig. 1.3.2

1.3.3 Class I and Class II pipes, pipelines valves, side and bottom valves, remote-controlled valves, venting valves, air pipe covers, flexible joints (including expansion joints), as well as the valves on the forepeak bulkhead, are subject to survey by the Register during manufacture.

#### 1.4 PROTECTION AND INSULATION OF PIPING

1.4.1 Constructional measures on corrosion protection.

1.4.1.1 In order to reduce the corrosion and erosion wear of ship sea water pipelines during their design and installation, the following shall be taken into account:

.1 a number of detachable joints shall be kept to a minimum. Detachable joints shall be located in places accessible for inspection, maintenance and repair;

.2 a number of shut-off devices on pipelines shall be kept to a minimum provided the system is functioning properly. Valves shall be located in places accessible for inspection, maintenance and repair;

.3 pipelines shall have the minimum number of bends. The radii of pipe bends shall be at least 2,5 times of their external diameter. Where the use of bends with less radii is required, the special fittings shall be applied;

.4 the use of welded bends made of segments for pipes of the nominal diameter less than 200 mm is not allowed. A number of segments for the 90° bend shall not be less than three. The use of bent or welded fittings for manufacturing of side or kingston valve branch pipes is not permitted (refer to 4.3.2.10);

.5 the use of tee-pipes, branch pipes, nipples, welded-on pieces and other components shall not result in reduction of open flow area of the main in the places of their installation;

.6 the average design flow velocity determined according to Formula (1.4.1.1.6) shall not exceed the values specified in Table 1.4.1.1.6.

The compliance of the average flow velocity  $V_{mean}$  in the above sections of pipelines as well as in kingston connecting channels with these requirements shall be confirmed by the calculation according to the formula

$$V_{mean} = 354Q/d^2 \quad (1.4.1.1.6)$$

where  $Q$  = permissible the maximum consumption at the design section, in m<sup>3</sup>/h;

$d$  = the internal diameter of a pipeline, in mm.

#### 1.4.2 Protection against general equal corrosion.

1.4.2.1 Steel pipes of sea water, as well as air and sounding pipes of ballast tanks, shall be protected against corrosion upon completion of bending and welding work by a method approved by the Register.

Table 1.3.2

Piping system for	Class I ( $p > p_2$ or $t > t_2$ )	Class II	Class III ( $p < p_1$ or $t < t_1$ )
Toxic and corrosive media	Without special safeguards	With special safeguards <sup>1</sup>	—
Inflammable media heated above flash point or having flash point below 60 °C <sup>2</sup> , liquefied gases	Without special safeguards	With special safeguards	—
Steam <sup>3</sup>	$p > 1,6$ or $t > 300$	Any pressure and temperature combination except the values indicated for Classes I and III	$p \leq 0,7$ and $t \leq 170$
Thermal oil <sup>3</sup>	$p > 1,6$ or $t > 300$		$p \leq 0,7$ and $t \leq 150$
Fuel oil, lubricating oil and hydraulic oil <sup>3</sup>	$p > 1,6$ or $t > 300$		$p \leq 0,7$ and $t \leq 60$
Other media <sup>3,4,5</sup>	$p > 4,0$ or $t > 300$		$p \leq 1,6$ and $t \leq 200$

<sup>1</sup>Not applicable to ammonia and other toxic media.

<sup>2</sup>Cargo oil pipes belong to Class III.

<sup>3</sup> $p$  = design pressure, MPa (refer to 2.3.2);

<sup>4</sup> $t$  = design temperature °C (refer to 2.3.5).

<sup>5</sup>Including water, air, gases, non-flammable hydraulic fluids.

<sup>6</sup>For open-ended pipes (drains, overflows, vents, exhaust gas lines, boiler escape pipes) irrespective of the temperature, Class III pipes may be used.

Table 1.4.1.1.6

Pipe material	Permissible average flow velocity, in m/s
Steel including galvanized, nodular graphite iron	2,5
Copper	0,9
Aluminium brass	2,0
Copper-nickel alloys:	
CuNi 5 Fe	2,0
CuNi 10 Fe	2,5
CuNi 30 Fe	3,5
Titanium alloys	10,0

Notes: 1. For pipelines of over 50 mm diameter with shaped elements having the rounding radii in the places of conjunctions with the main being equal to 0,15 diameter of the latter and more, bent with the bending radius in excess of 2,5 external diameters and without welded turns and throttle membranes, the flow velocity may be 30 % higher than specified in the Table.

2. In bilge, ballast, heel and trim systems the permissible values of a flow velocity may be 30 % higher than specified in the Table with regard to the possible flow velocity increase according to Note 1.

3. In fire-fighting, drenching, water screen, fire sprinkling systems not being constantly filled with water the flow velocity increase is allowed up to 5 m/s.

4. In systems with titanium pipes and valves of other materials, when permissible velocities are determined, the decisive components are those made of other materials.

The following methods may be used as such protection:

.1 zinc coating applied by a hot method. The minimum thickness of zinc coating layer shall not be less than 50 $\mu$ . Depending on the purpose of piping, the Register may require increasing of the coating thickness;

.2 zinc-filled paint coatings of not less than 120 $\mu$  in thickness;

.3 effective paint protective coatings (epoxy or equal thereto in water-resisting property).

When selecting the coating type, consideration shall be given to its resistance to the medium conveyed by the system in accordance with the operating conditions of the pipeline.

Aluminium coatings of pipelines are allowed in ballast tanks, in cargo inerted tanks, as well as in hazardous areas on the open deck provided their protection of the accidental impacts. Application of zinc or other metal coating does not relieve of measures for protection of pipelines against contact corrosion.

#### 1.4.3 Protection against contact corrosion.

1.4.3.1 One of the following methods to protect against contact corrosion shall be used when pipes made of different metals are joined in sea water systems: application of protective coating on internal pipelines surfaces, electrical insulation, cathodic protection, use of "sacrificial" branch pipes (refer to 1.4.3.5).

1.4.3.2 The protective water proofing coating (polymeric, paintwork or of other type approved by

the Register) is applied to contacting metals surfaces washed by sea water at the length of at least 5 pipe diameters from a contact point (but more than 1 m is not required). The planar oxidation may be used for titanium alloys instead of a water proofing. It is recommended to use coatings along with other methods of protection against contact corrosion.

1.4.3.3 Electrical insulation of different metals is effected by means of fitting electric insulating joints. In this case the following requirements shall be fulfilled:

.1 to protect heat exchangers, other equipment and pipes hooked up to them against contact corrosion, one electric insulating joint at the contact place of different metals and another one at a distance of at least 5 nominal those pipes diameters shall be fitted;

.2 to protect pipes and valves connected to them, bellows-shaped expansion joints and other similar pipeline components made of different metals against contact corrosion, electric insulating joints shall be fitted at both sides of those components;

.3 to protect interconnected pipes made of different materials against contact corrosion, the pipe made of any above pipe material and having a length of at least 5 nominal those pipes diameters shall be fitted between pipes using electric insulating joints at both ends;

.4 to protect hull structures from contact with bottom and side valves of nonferrous metal alloys, electric insulating joints shall be fitted at both ends of the bottom and side valves, and also on the very pipe and its branch pipes at a distance of at least 5 nominal pipe diameters if the pipe and the ship hull materials form an electric pair. Bottom, side and pipeline valves shall be electrically insulated from all types of joints (control, heating, blow-off, etc pipelines), which may form a metal contact between the valves and the ship hull. Where bottom and side valves are provided with the second shut-off valves made of the same metal, they shall be electrically insulated as a unified structure;

.5 pipes with two or more electric insulating joints shall be insulated from hangers;

.6 the structure of an electric insulating joint shall be approved by the Register, have the tightness required, be tested by hydraulic pressure in accordance with 21.2 and have an electrical resistance in a dry condition (prior to system filling) not less than 10 kOhm and not less than 1 kOhm following the system filling and hydraulic tests.

1.4.3.4 A cathodic protection shall be applied where sea water system components made of metals specified in Table 1.4.3.4 are in contact.

1.4.3.4.1 Protectors shall be fitted immediately between the surfaces of mating different metals. Where it is impossible, they may be fitted on the

Table 1.4.3.4

Metal combination		Material subjected to corrosion	Protector material
Carbon, low-alloy steel, cast iron	Copper, brass, bronze, copper-nickel alloys, corrosion-resistant steel, titanium alloys	Carbon, low-alloy steel, cast iron	Zinc alloy
Copper, brass, bronze, copper-nickel alloys	Corrosion-resistant steel of austenitic class, titanium alloys	Copper, brass, bronze, copper-nickel alloys	Carbon steel
Copper, brass	Corrosion-resistant non-austenitic steel	Copper, brass	Carbon steel
Bronze, copper-nickel alloys	Corrosion-resistant non-austenitic steel	Any material specified may be subjected to corrosion	Carbon steel
Corrosion-resistant steel	Titanium alloy	Corrosion-resistant steel	Carbon steel
Corrosion-resistant steel of austenitic class	Corrosion-resistant non-austenitic steel	Any material specified may be subjected to corrosion	Carbon steel
Brass	Bronze, copper, copper-nickel alloys	Brass	Carbon steel

surface protected as close to the pipe contact place as possible (at least one diameter).

**1.4.3.4.2** In pipelines with valves and pipes of different metals, protectors shall be fitted behind each valve along a flow. For permanently closed valves and in sections with changing flow motion direction, protectors shall be fitted at both valve sides.

**1.4.3.4.3** A corrosion-resistant steel, tin brass and manganese bronze, aluminium bronze may be used in sea water if only a cathodic protection is provided.

**1.4.3.4.4** When fitting protectors, the reliable electrical contact of a protector with an article protected shall be provided.

**1.4.3.4.5** The protector design shall permit its replacement, which is effected after the protector life cycle expires. In this case, joints tightness shall not be broken.

**1.4.3.4.6** The protector service period shall be at least 2,5 years (at least 3 years for protection of kingston and side branch pipes) and shall be determined according to the formula

$$T = A \frac{M}{S} \quad (1.4.3.4.6)$$

where  $T$  = protector service period, in years;  
 $M$  = mass of a protector working metal, in kg;  
 $S$  = area of protected surface, in m<sup>2</sup>; the protected pipe surface therewith is assumed equal to an internal surface area of 5 internal diameters long;  
 $A$  = coefficient equal to 0,75 for zinc protector and to 1,71 for steel one.

**1.4.3.5** Where other methods of protection against contact corrosion can not be used, it is permitted to apply "sacrificial" branch pipes.

**1.4.3.5.1** The "sacrificial" branch pipe is the thick-walled cylindrical section of a carbon steel pipe intended for displacement of a contact zone of pipelines components made of nonferrous metals and alloys from essential steel structures and equipment. The "sacrificial" branch pipe shall not be internally coated.

**1.4.3.5.2** "Sacrificial" branch pipes shall be machined of forgings or rolled products. The length of a "sacrificial" branch pipe shall be at least 1,5 of the internal pipe diameter. The sealing flange surface of the "sacrificial" branch pipe being in contact with

a different metal shall be protected against contact corrosion by facing or by another approved method of cladding metal on the contacting item.

**1.4.3.5.3** The wear margin of a "sacrificial" branch pipe wall shall provide a pipeline service period of at least 10 years on a basis of the total wall corrosion rate of 1,5 mm/year.

**1.4.3.5.4** The "sacrificial" branch pipe shall be located in place accessible for inspection and replacement. The spare "sacrificial" branch pipe shall be on the ship.

**1.4.3.5.5** Dismantling, inspection of contact surfaces and measurements of "sacrificial" branch pipe wall thicknesses shall be carried out at least once in 5 years.

#### 1.4.4 Protection against excessive pressure.

**1.4.4.1** Pipelines, in which pressure in excess of the design pressure is possible, shall be equipped with safety devices so that the pressure would not exceed the design value for the pipes.

The liquid diversion from relief valves of pumps transferring flammable liquids shall be effected into the suction side of the pump or to the suction pipeline. This requirement does not apply to centrifugal pumps.

**1.4.4.2** Where provision is made for a reducing valve on the pipeline, a pressure gauge and a safety valve shall be installed after the reducing valve.

An arrangement for by-passing the reducing valve is allowed for use.

#### 1.4.5 Insulation of piping.

Insulation of piping shall comply with 4.6, Part VII "Machinery Installations" and 8.2, Part XII "Refrigerating Plants".

#### 1.4.6 Protection against green sea forces.

**1.4.6.1** The requirements of 1.4.6 are applicable to all ship types of sea-going service of length 80 m or more, where the height of the exposed deck over the forward  $1/4L$  is less than  $0,1L$  or 22 m above the summer load waterline, whichever is the lesser.

The requirements of 1.4.6.1 to 1.4.6.5 do not apply to ships constructed in compliance with the

Common Structural Rules for Double-Hull Oil Tankers. For the above ships the requirements of 11.1.2 and 11.1.3, Part XVIII "Common Structural Rules for Double-Hull Oil Tankers" shall be applied.

**1.4.6.2** Air pipes of tanks, ventilator pipes and their closing devices located within the forward quarter length shall have strength sufficient to resist green sea forces at open sea. The requirements of 1.4.6 do not apply to cargo tank venting systems.

**1.4.6.3** Applied loading.

**1.4.6.3.1** The pressures  $p$ , in  $\text{kN/m}^2$ , acting on air pipes, ventilator pipes and their closing devices may be determined by the formula

$$p = 0,5\rho V^2 C_d C_s C_p \quad (1.4.6.3.1)$$

where  $\rho$  = density of sea water ( $1,025 \text{ t/m}^3$ );  
 $V$  = velocity of water over the fore deck, m/s;  
 $V = 13,5$  for  $d \leq 0,5d_1$ ;  
 $V = 13,5\sqrt{2(1-d/d_1)}$  for  $0,5d_1 < d < d_1$ ;  
 $d$  = distance from summer load waterline to exposed deck, in m;  
 $d_1 = 0,1L$  or  $22 \text{ m}$ , whichever is the lesser, in m;  
 $C_d$  = shape coefficient taken equal to:  
 0,5 – for pipes;  
 1,3 – for air pipes or ventilator heads;  
 0,8 – for air pipes or ventilator heads of cylindrical form with its axis in the vertical direction;  
 $C_s$  = slamming coefficient taken equal to 3,2;  
 $C_p$  = protection coefficient taken equal to:  
 0,7 – for pipes and ventilator heads located immediately behind a breakwater or forecastle,  
 1,0 – elsewhere and immediately behind a bulwark.

**1.4.6.3.2** Forces acting in horizontal direction on the pipes and their closing devices may be determined by Formula (1.4.6.3.1) using the largest projected area of each component.

**1.4.6.4** Strength requirements.

**1.4.6.4.1** Bending stresses and loads in air and ventilator pipes shall be determined at critical positions: at penetration pieces, at weld or flange connections, at toes of supporting brackets. Bending stresses shall not exceed  $0,8\sigma_y$ , where  $\sigma_y$  is the yield stress or proof stress of steel at 0,2 per cent

elongation at room temperature. Irrespective of corrosion protection, a corrosion addition to the net section of 2 mm shall be then applied.

**1.4.6.4.2** For standard pipes of 760 mm height closed by heads of not more than the tabulated projected area, pipe thicknesses and bracket heights are specified in Table 1.4.6.4.2. Where brackets are required, three or more radial brackets shall be fitted.

Brackets shall be of gross thickness 8 mm or more, of minimum length not less than 100 mm, and height according to Table 1.4.6.4.2 but shall not extend over the joint flange for the head. Bracket toes at the deck shall be suitably supported.

**1.4.6.4.3** For other configurations, loads and means of support shall be determined in accordance with 1.4.6.3 and 1.4.6.4. Brackets, where fitted, shall be of suitable thickness and length according to their height. Pipe thickness shall not be taken less than as indicated in 10.1.4.

**1.4.6.4.4** For standard ventilators of 900 mm height, pipe thicknesses and bracket heights are specified in Table 1.4.6.4.4. Brackets, where required shall be as specified in 1.4.6.4.2.

**1.4.6.4.5** For ventilators of height greater than 900 mm, brackets or alternative means of support are subject to pipe strength calculations.

**1.4.6.4.6** All component parts and connections of the air pipe or ventilator shall be capable of withstanding the loads defined in 1.4.6.3.

**1.4.6.5** Rotating type mushroom ventilator heads are not permitted for installation in the areas defined in 1.4.6.2.

## 1.5 WELDING AND NON-DESTRUCTIVE TESTING OF WELDS

**1.5.1** Welding and non-destructive testing of welds in pipes shall be effected in compliance with 2.5 and 3, Part XIV "Welding".

Table 1.4.6.4.2

760 mm air pipe thickness and bracket standards

Nominal pipe diameter, mm	Minimum pipe thickness, mm	Maximum projection area of head, $\text{cm}^2$	Height of bracket, mm
50	6,0	—	520
65	6,0	—	480
80	6,3	—	460
100	7,0	—	380
125	7,8	—	300
150	8,5	—	300
175	8,5	—	300
200	8,5 <sup>1)</sup>	1900	300 <sup>2)</sup>
250	8,5 <sup>1)</sup>	2500	300 <sup>2)</sup>
300	8,5 <sup>1)</sup>	3200	300 <sup>2)</sup>
350	8,5 <sup>1)</sup>	3800	300 <sup>2)</sup>
400	8,5 <sup>1)</sup>	4500	300 <sup>2)</sup>

<sup>1)</sup> Brackets shall be fitted where the pipe thickness is less than 10,5 mm, or where the tabulated projected head area is exceeded.

<sup>2)</sup> For other air pipe heights, the relevant requirements of 1.4.6.4.3 shall be applied.

Table 1.4.6.4.4

## 900 mm ventilator pipe thickness and bracket standards

Nominal pipe diameter, mm	Minimum pipe thickness, mm	Minimum projection area of head, cm <sup>2</sup>	Height of bracket, mm <sup>1)</sup>
80	6,3	—	460
100	7,0	—	380
150	8,5	—	300
200	8,5	550	—
250	8,5	880	—
300	8,5	1200	—
350	8,5	2000	—
400	8,5	2700	—
450	8,5	3300	—
500	8,5	4000	—

<sup>1)</sup>For other ventilator heights the relevant requirements of 1.4.6.4.5 shall be applied.

## 2 METAL PIPING

### 2.1 MATERIAL, MANUFACTURE AND APPLICATION

**2.1.1** The materials, used for pipes and valves, as well as the methods of testing the materials shall comply with the requirements of Part XIII "Materials".

The fuel oil pipes shall be manufactured of steel or other material meeting the Register requirements as to its strength and fire-resistance. These requirements apply to lubricating oil pipes in machinery spaces and to pipes conveying other flammable oil products including hydraulic and thermal liquids if they are in spaces with sources of ignition.

The coatings and parts of non-metallic materials used during manufacture of valves shall be compatible with the medium conveyed at working pressure within the whole range of working temperatures.

The pipes and valves of fire extinguishing systems shall comply with 3.1.4.2, Part VI "Fire Protection".

**2.1.2** In general, pipes and valves of carbon steel and carbon-manganese steel shall be used for media with temperature not exceeding 400 °C, of low-alloy steel — with temperature not exceeding 500 °C.

These steels may be admitted for temperatures higher than the above mentioned, if their mechanical properties and the average stress to produce rupture in 100 000 hours at the design temperature comply with the effective standards and are guaranteed by the steel maker as suitable for high temperature service.

Pipes and valves for media with temperature above 500 °C shall be manufactured of alloy steel. Exhaust gas pipes are excluded from this requirement.

**2.1.3** Copper and copper alloy pipes shall be seamless drawn pipes or other type approved by the Register.

Copper pipes for Classes I and II shall be seamless.

Pipes and valves of copper and copper alloys shall generally be used for media having temperature not in excess of 200 °C, and those of copper-nickel alloys, for temperature not over 300 °C. Bronze valves may be admitted for media having temperatures up to 260 °C.

**2.1.4** Grey cast iron may be admitted for pipes and valves of piping in Class III used at ambient temperature not lower than -15 °C. In this case, the ultimate strength of the grey cast iron shall not be less than 200 MPa, and that of the fitting casings and shaped components — not less than 300 MPa. Apart from cargo pipelines, the permissible working pressure in the pipelines of grey cast iron shall not exceed 1 MPa and for steam pipelines — 0,3 MPa.

Pipes and valves of grey cast iron may be also used for cargo lines with pressures up to 1,6 MPa on

the weather deck, inside cargo and slop tanks, except for the manifolds, their valves and connections to the cargo hoses.

The grey cast iron shall not be used for:

.1 pipes and valves handling media with temperatures above 220 °C;

.2 pipes and valves subject to water hammer, increased strains and vibration;

.3 pipes directly connected to the shell plating;

.4 valves fitted directly on the shell plating and collision bulkhead;

.5 valves under static head, fitted directly on fuel and lubricating oil tanks, unless protected against mechanical damage by a method approved by the Register;

.6 fire smothering systems;

.7 ballast lines inside cargo and slop tanks.

**2.1.5** Spheroidal or nodular graphite cast iron may be admitted for pipes and valves of piping in Classes II and III including ballast, bilge and cargo lines, if the elongation of this cast iron is not less than 12 per cent. Where the elongation is less than that required, the area of application of the pipes and valves of spheroidal or nodular graphite cast iron shall be the same as specified in 2.1.4 for the grey cast iron.

The working temperature for piping components made of spheroidal graphite cast iron of perlitic or ferritic-perlitic structure shall not exceed 300 °C and for the cast iron of ferritic structure 350 °C.

The impact toughness (*KCU*) of the spheroidal graphite cast iron for pipes and valves used at the temperature lower than -15 °C shall not be less than 20 J/cm<sup>2</sup>.

Ship bottom and side valves as well as the valves and fittings referred to in 4.3.2.4, 4.3.2.6 to 4.3.2.7 and the valves on the collision bulkhead, fuel and lube oil tanks may be admitted to be of spheroidal graphite cast iron of fully ferritic structure in accordance with Table 3.9.3.1, Part XIII "Materials".

**2.1.6** Pipes up to 50 mm in diameter and valves of ductile cast iron of ferritic structure with elongation more than 12 per cent may be used for services mentioned in 2.1.5 at the working temperature not lower than -15 °C and not higher than 350 °C and under working pressure up to 2 MPa.

The area of application of pipes and valves made of ductile cast iron with elongation less than 12 per cent shall be the same as specified in 2.1.4 for products made of grey cast iron.

**2.1.7** The application of pipes, shaped elements, as well as filter bodies, valves and other piping compo-

nents made of aluminium alloys is not permitted in fuel oil and lubricating oil systems. The requirements of this para fully apply to hydraulic systems containing flammable liquids in machinery spaces of category A and in other space with a high fire risk.

**2.1.8** The plugs and threaded portion of deck bushes of sounding pipes, terminating on the open decks, shall be of bronze or brass.

**2.1.9** Sight-glasses on fuel oil and oil pipes shall be refractory.

**2.1.10** Materials other than steel with a melting point below 930 °C and with an elongation below 12 % shall be used for the components of engines, turbines, gears, or other machinery containing fuel or oil and which are considered acceptable for the following applications:

**.1** internal pipes which cannot cause any release of flammable fluid onto the machinery or into machinery space in case of failure;

**.2** components that are only subjects to liquid spray on the inside when the machinery is running, such as machinery covers, rocker box covers, camshaft and covers, inspection plates and sump tanks. It is a condition that the pressure inside these components and all the elements contained therein is less than 0,18 N/mm<sup>2</sup>, and that wet sumps have a volume not exceeding 100 litres; or

**.3** in case other than specified in 2.1.10.1 and 2.1.10.2, components attached to machinery which satisfy fire test criteria according to standard ISO 19921: 2005/19922: 2005 or other standards which are recognized by the Register equivalent, and which retain mechanical properties adequate for the intended installation.

## 2.2 RADII OF PIPE BENDS, HEAT TREATMENT AFTER BENDING

**2.2.1** The inner radius of pipe bend of the boiler blow off pipes shall be at least 3,5  $d_1$  ( $d_1$  = pipe inside diameter).

The inner radius of bend of the steel and copper pipes subjected to a pressure exceeding 0,49 MPa or a working medium temperature exceeding 60 °C, as well as bending radius of pipes with allowance for thermal expansion, shall be at least 2,5 $d$  ( $d$  = pipe outside diameter).

On agreement with the Register, bending to a lesser radius may be permitted, provided no thinning of pipe wall below the values stated in 2.3 would occur during the bending.

**2.2.2** Hot bending of steel pipes shall be generally carried out in the temperature range 1000 to 850 °C; however, the temperature may decrease to 750 °C during the bending process.

For pipes, the bending of which is carried out within this temperature range, the following applies:

**.1** for C, C-Mn and C-Mo steels, no subsequent heat treatment is required;

**.2** for 1 Cr — 0,5 Mo steel with a wall thickness greater than 8 mm, a subsequent stress relieving heat treatment in the temperature range 620 to 680 °C is required;

**.3** for 2,25 Cr — 1 Mo and 0,5 Cr — 0,5 Mo — 0,25 V steels of all thickness, a subsequent stress relieving heat treatment in the temperature range 650 to 720 °C is required except for pipes with a wall thickness ≤ 8 mm, diameter ≤ 100 mm and the maximum service temperature up to 450 °C, for which no subsequent heat treatment may be carried out.

**2.2.3** When the hot bending is carried out outside the temperature range stated in 2.2.2, a subsequent new heat treatment in accordance with Table 2.2.3 is generally required.

Table 2.2.3

Type of steel	Heat-treatment and temperature (°C)
C and C — Mn 0,3 Mo 1 Cr — 0,5 Mo	Normalizing 880 to 940 Normalizing 900 to 940 Normalizing 900 to 960 Tempering 640 to 720
2,25 Cr — 1 Mo	Normalizing 900 to 960 Tempering 650 to 780
0,5 Cr — 0,5 Mo — 0,25 V	Normalizing 930 to 980 Tempering 670 to 720

**2.2.4** After cold bending when  $r=4d$ , a complete heat treatment in accordance with Table 2.2.3 is generally required in any case, a stress relieving heat treatment is required for 0,3 Mo steel with a wall thickness ≥ 15 mm at 580 to 640 °C, 1 Cr — 0,5 Mo steel with a wall thickness ≥ 8 mm at 620 to 680 °C and for 2,25 Cr — 1 Mo and 0,5 Cr — 0,5 Mo — 0,25 V steel with a wall thickness ≥ 8 mm, diameter ≥ 100 mm and service temperature above 450 °C at 650 to 720 °C.

**2.2.5** Copper and copper-alloy pipes, except for the pipes of measuring instruments, shall be annealed before hydraulic testing.

**2.2.6** Preheating before welding and postweld heat treatment shall be effected in accordance with 2.5.5 to 2.5.7, Part XIV "Welding".

## 2.3 METAL PIPE WALL THICKNESS

**2.3.1** The wall thickness of metal pipes (except cast iron pipes) operating under the internal pressure shall correspond to the greater of the values determined from

Table 2.3.8 or by the following formula:

$$S = \frac{S_0 + b + c}{1 - (a/100)} \quad (2.3.1)$$

where:  $S_0 = dp/(2\sigma\phi + p)$ ;  
 $S_0$  = theoretical wall thickness, mm;  
 $d$  = outside diameter of the pipe, mm;  
 $p$  = design pressure determined in accordance with 2.3.2, MPa;  
 $\phi$  = weld efficiency factor taken in accordance with 2.3.3;  
 $b$  = allowance for a reduction of pipe wall thickness because of bending taken in accordance with 2.3.4, mm;  
 $\sigma$  = permissible (normal) stress determined in accordance with 2.3.5 to 2.3.7, MPa;  
 $c$  = corrosion addition taken in accordance with Table 2.3.1-1 for steel pipes and Table 2.3.1-2 for pipes of nonferrous metals, mm;  
 $a$  = negative manufacturing tolerance for pipe wall thickness, % (when pipes without negative allowance are used,  $a=0$ ).

Table 2.3.1-1

Allowance  $c$  for corrosion for steel pipes

Working medium, piping service	$c$ , mm
Superheated steam	0,3
Saturated steam	0,8
Heating steam coils for water and fuel oil products in tanks and cargo tanks	2,0
Feed water in open circuit systems	1,5
Feed water in closed circuit systems	0,5
Blow-down of boilers	1,5
Compressed air	1,0
Hydraulic oil systems	0,3
Lubricating oil	0,3
Fuel oil	1,0
Cargo pipelines	2,0
Liquefied gas	0,3
Refrigerant piping	0,3
Fresh water	0,8
Sea water	3,0

Notes: 1. On agreement with the Register, the allowance for corrosion may be reduced for pipes protected against corrosion by special coatings, linings, etc.  
 2. Where pipes of steel with sufficient corrosion resistance are used, the allowance for corrosion may be reduced to zero.  
 3. For pipes passing through tanks and on the open decks the table values shall be increased by the allowance for the influence of the external medium, which is assumed for the appropriate medium in accordance with the present Table.

Table 2.3.1-2

Allowance  $c$  for corrosion for pipes of nonferrous metals and alloys

Pipe material	$c$ , mm
Copper, brass, copper-tin alloys and similar alloys, except those with lead content	0,8
Copper-nickel alloys (with Ni content $\geq 10\%$ )	0,5

Note. Where pipes of special alloys with sufficient corrosion resistance are used, the allowance for corrosion may be reduced to zero.

**2.3.2** The design pressure, on the basis of which pipe strength calculations are made, shall be assumed equal to the maximum working pressure of the system. Where safety relief valves are fitted, the

design pressure shall be their highest set pressure. Pipelines and components of piping systems not protected by safety valves or may be disconnected from their safety valves, shall be calculated for the maximum possible pressure at the outlet of the pumps connected.

For pipelines containing heated fuel oil, the design pressure shall be taken according to Table 2.3.2.

Table 2.3.2

Determination of design pressure for fuel oil systems

Working pressure $P$ , MPa	Working temperature $T$ , °C	
	No more than 60	More than 60
No more than 0,7	0,3MPa or $P_{max}$ (the greater of two values)	0,3MPa or $P_{max}$ (the greater of two values)
More than 0,7	$P_{max}$	1,4MPa or $P_{max}$ (the greater value)

For pipelines of steering gear the design pressure shall be assumed in compliance with 6.2.8.1, Part IX "Machinery".

In particular cases not provided by the Rules the design pressure is subject to special consideration by the Register.

**2.3.3** The strength factor  $\phi$  in strength calculations shall be taken as 1 for seamless pipes and approved welded pipes, which are considered to be equal to seamless pipes.

For other welded pipes the strength factor  $\phi$  shall be assigned considering the requirements of 2.1.6.1-1, Part X "Boilers, Heat Exchanges and Pressure Vessels".

**2.3.4** The allowance for an actual reduction of pipe wall thickness because of bending shall be chosen in such a way that the stresses in the bent part of the pipe because of internal pressure do not exceed the permissible stresses.

Where precise values of thickness reduction while bending are not known, the allowance  $b$ , mm, may be obtained by the formula

$$b = 0,4S_0d/R \quad (2.3.4)$$

where  $R$  = mean radius of pipe bend, mm.

**2.3.5** In strength calculations the permissible stresses are taken considering the following properties of material and working conditions:

$R_{m/20}$  = ultimate resistance at room temperature, MPa;

$R_{eL/t}$  = the minimum yield strength at the design temperature, MPa;

$R_{0,2/t}$  = conventional yield strength at the design temperature, MPa;

$R_{m/t}^{100000}$  = ultimate long-term strength for 100 000 hours at the design temperature, MPa;

$R_{p1\%/t}^{100000}$  = 1 per cent of creep limit for

100 000 hours at the design temperature, MPa.

The design temperature  $t$  for determining permissible stresses is taken as the maximum temperature of the medium inside the pipes.

**2.3.5.1** For carbon or alloy steel pipes the permissible design stresses are chosen equal to the lowest of the following values:

$$R_{m/20}/2,7; R_{eL/t}/1,8 \text{ or } R_{0,2/t}/1,8; R_{m/t}^{100\ 000}/1,8; R_{p1\%/t}^{100\ 000}/1,0.$$

When the design temperature is not included in the creep limit of the material, the permissible stresses on the creep limit are not compulsory for examination.

**2.3.5.2** For copper and copper alloys pipes the permissible stresses shall be determined in accordance with Table 2.3.5.2.

**2.3.5.3** The permissible stresses for aluminium and titanium pipes in the strength calculations are assumed equal to the minimum of the following values:

$$R_{m/20}/4,0; R_{0,2/t}/1,6; R_{m/t}^{100\ 000}/1,6.$$

When the design temperature is not included in the creep limit of the material, the permissible stresses on the creep limit are not compulsory for examination.

**2.3.6** Steam pipes with an external diameter of 80 mm and over for superheated steam at a temperature of 350 °C and over shall be calculated for stresses caused by thermal expansion, and flanged joints — for strength and tightness.

The calculations of stresses in pipes because of thermal expansion shall comply with the requirements of 18.3.

**2.3.7** The wall thickness  $t_{\min}$ , in mm, of cast iron pipeline components shall not be less than that obtained from the formula

$$t_{\min} = k(0,5 + 0,001D_{nom}) \quad (2.3.7)$$

where  $D_{nom}$  = nominal diameter, in mm;

$k$  = factor taken equal to:

- 9 — for pipes;
- 14 — for T-joints and valve bodies;
- 12 — for joints.

Moreover, the wall thickness of cast iron pipes

and valves under internal pressure shall not be less than that obtained from Formula (2.3.1), and the allowance for a reduction of pipe wall thickness because of bending in this case is  $b = 0$ ;

weld efficiency factor  $\varphi$  taken equal to:

- 1 — for pipes and couplings;
- 0,4 — for bends, T-joints and four-way unions;
- 0,25 — for fitting bodies;

permissible stress  $\sigma$  determined with regard to 2.1.4.3, 2.1.4.6, and 2.1.5.5, Part X "Boilers, Heat Exchangers and Pressure Vessels";

corrosion addition  $c$  due to sea water is:

4 mm — for cast iron of ferritic and ferritic-perlitic structure;

3 mm — for cast iron of perlitic structure;

for media with low corrosivity, corrosion addition  $c$  may be reduced on agreement with the Register.

**2.3.8** The wall thickness of steel, copper, copper and titanium alloys pipes shall not be less than indicated in Table 2.3.8.

## 2.4 PIPE JOINTS

**2.4.1** Use of welded, flanged, threaded and mechanical joints, made in accordance with the standards approved by the Register, is allowed.

### 2.4.2 Welded joints.

**2.4.2.1** Welded butt joints may be accomplished with or without special provisions for full root penetration. Welded butt joints of full penetration type with special provisions for root side quality, for instance, performed with the use of double-sided welds, backing strap or other equivalent methods, are allowed for piping of any class and diameter.

Welded butt joints of full penetration type without special provisions for root side quality are allowed for Class II and III pipelines without diameter restrictions.

**2.4.2.2** Slip-on and socket welded joints shall have sleeves and sockets of adequate dimensions,

Table 2.3.5.2

Permissible stresses  $\sigma_{perm}$  for pipes of copper and copper alloys

Pipe material	Heat treatment	Minimum tensile strength, MPa	$\sigma_{perm}$ , MPa, at working medium temperature, °C										
			50	75	100	125	150	175	200	225	250	275	300
Copper	Annealing	220	41	41	40	40	34	27	19	—	—	—	—
Aluminium brass	Ditto	320	78	78	78	78	78	51	25	—	—	—	—
Copper-nickel 95/5 and 90/10	Ditto	270	69	69	68	66	64	62	59	56	52	48	44
Copper-nickel 70/30	Ditto	360	81	79	77	76	74	72	70	68	66	64	62

Notes: 1. Intermediate values shall be determined by linear interpolation.

Minimum wall thickness of metal pipes, mm

Table 2.3.8

External diameter, mm	Pipes									
	Steel						Copper	Copper alloys	Corrosion-resistant steel	Titanium-based alloys
	Pipes of systems other than stated in columns 3 — 7	Venting, overflow and sounding pipes of structural tanks, except for those stated in column 5 of the Table and in 10.1.4.	Sea water pipes (bilge, ballast, cooling water, fire extinguishing systems, etc.)	Bilge, air, overflow and sounding pipes passing through ballast and fuel tanks; ballast pipes passing through fuel tanks; fuel pipings passing through ballast tanks (refer also to 9.2.3)	Pipings of CO <sub>2</sub> fire extinguishing system					
					from cylinders to starting valves	from starting valves to discharge nozzles				
1	2	3	4	5	6	7	8	9	10	11
<8	1,0	—	—	—	—	—	—	—	1,0	0,7
8,0	1,2	—	—	—	—	—	1,0	0,8	1,0	0,8
10,2	1,6	—	—	—	—	—	1,0	0,8	1,0	0,8
12,0	1,6	—	—	—	—	—	1,2	1,0	1,0	1,0
13,5	1,8	—	—	—	—	—	1,2	1,0	1,0	1,0
16,0	1,8	—	—	—	—	—	1,2	1,0	1,0	1,0
17,2	1,8	—	—	—	—	—	1,2	1,0	1,0	1,0
19,3	1,8	—	—	—	—	—	1,2	1,0	1,0	1,0
20,0	2,0	—	—	—	—	—	1,2	1,0	1,0	1,0
21,3	2,0	—	3,2	—	3,2	2,6	1,2	1,0	1,6	1,0
25,0	2,0	—	3,2	—	3,2	2,6	1,5	1,2	1,6	1,0
26,9	2,0	—	3,2	—	3,2	2,6	1,5	1,2	1,6	1,0
30,0	2,0	—	3,2	—	4,0	3,2	1,5	1,2	1,6	1,0
33,7	2,0	—	3,2	—	4,0	3,2	1,5	1,2	1,6	1,0
38,0	2,0	4,5	3,6	6,3	4,0	3,2	1,5	1,2	1,6	1,0
42,4	2,0	4,5	3,6	6,3	4,0	3,2	1,5	1,2	1,6	1,0
44,5	2,0	4,5	3,6	6,3	4,0	3,2	1,5	1,2	1,6	1,0
48,3	2,3	4,5	3,6	6,3	4,0	3,2	2,0	1,5	1,6	1,5
51,0	2,3	4,5	4,0	6,3	4,5	3,6	2,0	1,5	1,6	1,5
54,0	2,3	4,5	4,0	6,3	4,5	3,6	2,0	1,5	1,6	1,5
57,0	2,3	4,5	4,0	6,3	4,5	3,6	2,0	1,5	1,6	1,5
60,3	2,3	4,5	4,0	6,3	4,5	3,6	2,0	1,5	2,0	1,5
63,5	2,3	4,5	4,0	6,3	5,0	3,6	2,0	1,5	2,0	1,5
70,0	2,6	4,5	4,0	6,3	5,0	3,6	2,0	1,5	2,0	1,5
76,1	2,6	4,5	4,5	6,3	5,0	3,6	2,0	1,5	2,0	1,5
82,5	2,6	4,5	4,5	6,3	5,6	4,0	2,0	1,5	2,0	1,5
88,9	2,9	4,5	4,5	7,1	5,6	4,0	2,5	2,0	2,0	2,0
101,6	2,9	4,5	4,5	7,1	6,3	4,0	2,5	2,0	2,0	2,0
108,0	2,9	4,5	4,5	7,1	7,1	4,5	2,5	2,0	2,0	2,0
114,3	3,2	4,5	4,5	8,0	7,1	4,5	2,5	2,0	2,3	2,0
127,0	3,2	4,5	4,5	8,0	8,0	4,5	2,5	2,0	2,3	2,0
133,0	3,6	4,5	4,5	8,0	8,0	5,0	3,0	2,5	2,3	2,0
139,7	3,6	4,5	4,5	8,0	8,0	5,0	3,0	2,5	2,3	2,0
152,4	4,0	4,5	4,5	8,8	8,8	5,6	3,0	2,5	2,3	2,0
159,0	4,0	4,5	4,5	8,8	8,8	5,6	3,0	2,5	2,3	2,0
168,3	4,0	4,5	4,5	8,8	8,8	5,6	3,0	2,5	2,3	2,0
177,8	4,5	5,0	5,0	8,8	—	—	3,0	2,5	2,3	2,0
193,7	4,5	5,4	5,4	8,8	—	—	3,5	3,0	2,3	2,5
219,1	4,5	5,9	5,9	8,8	—	—	3,5	3,0	2,6	2,5
244,5	5,0	6,3	6,3	8,8	—	—	3,5	3,0	2,6	2,5
267,0	5,0	6,3	6,3	8,8	—	—	3,5	3,0	2,6	2,5
273,0	5,0	6,3	6,3	8,8	—	—	4,0	3,5	2,9	3,0
298,5	5,6	6,3	6,3	8,8	—	—	4,0	3,5	2,9	3,0
323,9	5,6	6,3	6,3	8,8	—	—	4,0	3,5	3,6	3,0
355,6	5,6	6,3	6,3	8,8	—	—	4,0	3,5	3,6	3,0
368,0	5,6	6,3	6,3	8,8	—	—	4,0	3,5	3,6	3,0
406,4	6,3	6,3	6,3	8,8	—	—	4,0	3,5	4,0	3,0
419,0	6,3	6,3	6,3	8,8	—	—	4,0	3,5	4,0	3,0

Table 2.3.8 — continued

1	2	3	4	5	6	7	8	9	10	11
457,2 508,0	6,3 —	6,3 —	6,3 —	8,8 —	— —	— —	4,0 4,5	3,5 4,0	4,0 4,0	3,0 3,5

Notes: 1. For pipes with thicknesses and diameters indicated in the Table, the nearest values specified in national and international standards may be accepted on agreement with the Register.  
 2. For the tabulated values no allowance need be made for negative manufacturing tolerance and reduction in thickness due to bending.  
 3. For the pipes with diameters greater than 450 mm, the minimum thickness shall be taken in accordance with the standards agreed upon with the Register; the minimum thickness value shall not be taken less than that specified for pipes with diameter of 450 mm.  
 4. The minimum internal diameters of drain, sounding, air and overflow pipes shall be accepted in compliance with 7.2.3, 10.1.12, 10.2.8 and 10.4.7 accordingly.  
 5. For pipes protected against corrosion by special coatings, linings, etc., the minimum wall thicknesses of pipes, listed in columns 3, 4 and 5, may be reduced by an amount of not more than 1 mm.  
 6. For sounding pipes, the thicknesses stated in cols 3 and 5 apply to the parts, which are outside the tanks, for which these pipes are intended.  
 7. For threaded pipes, the wall thickness shown is the minimum thickness at the bottom of the thread.  
 8. The thicknesses stated in columns 6 and 7 apply to the pipes, which are galvanized on the inside.  
 9. The minimum wall thicknesses of bilge and ballast lines passing through cargo tanks, as well as cargo shall be not less than specified in 9.10.1.  
 10. The Table is not applicable to the exhaust gas piping.  
 11. For low pressure carbon dioxide system the wall thickness of pipes on a length from tank to discharge nozzles shall be the same as in column 7.  
 12. Wall thickness of scuppers and discharge pipes shall not be less than stated in 4.3.2.  
 13. Wall thickness of ballast and air pipes passing through cargo tanks shall comply with the requirements of Table 9.10.1.

meeting the requirements of the standards approved by the Register. Slip-on sleeve and faucet welded joints may be used for Class III pipelines regardless of pipe diameter.

In some cases such joints may be used for Class I and II pipelines with outside diameter up to 88,9 mm except the pipelines conveying toxic or corrosive media and for operation under heavy fatigue loads, excessive corrosion and erosion.

**2.4.2.3 Welding and non-destructive testing** shall be carried out in accordance with 2.5 and 3.2, Part XIV "Welding".

**2.4.3 Flange connections.**

**2.4.3.1 Dimensions and shape of flanges and connecting bolts** shall comply with the standards approved by the Register.

The applied seals shall be compatible with the conveyed medium at the design pressure and temperature.

Flange connections shall be chosen in accordance with the national or international standards approved by the Register, depending on the medium being conveyed, design pressure and temperature, external and cycling loads, as well as the pipeline location.

**2.4.3.2 Connection of flanges and pipes** shall be made in accordance with Fig. 2.4.3.2.

Other types of joints may be accepted by the Register upon the special consideration.

**2.4.3.3 Choice of flange and pipe joints type** depending on pipeline class shall be conducted in accordance with Table 2.4.3.3.

**2.4.4 Tapered threaded connections.**

**2.4.4.1 Threaded connections** shall be accomplished in compliance with the requirements of the approved national or international standards. Such connections shall not be applied in systems conveying

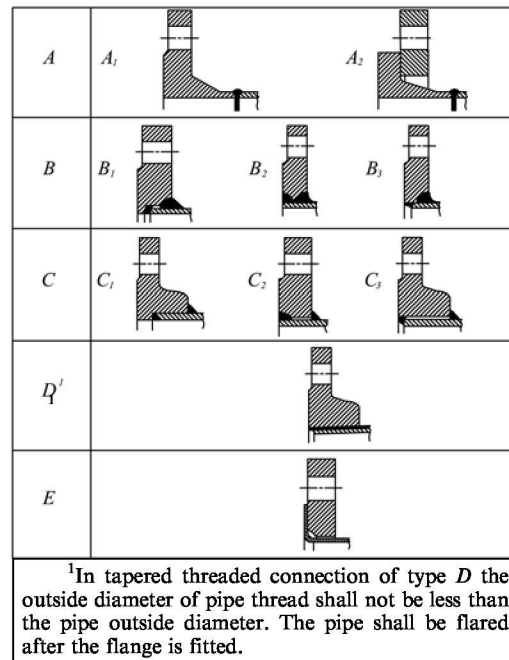

<sup>1</sup>In tapered threaded connection of type D the outside diameter of pipe thread shall not be less than the pipe outside diameter. The pipe shall be flared after the flange is fitted.

Fig. 2.4.3.2

Table 2.4.3.3

Class of piping	Toxic, corrosive and combustible media, liquefied gas <sup>1</sup>	Fuel oil, lubricating oil, combustible hydraulic oil	Steam	Other media <sup>2</sup>
I	A, B <sup>5</sup>	A, B	A, B <sup>3,4</sup>	A, B
II	A, B, C	A, B, C	A, B, C, D <sup>5</sup>	A, B, C, D <sup>5</sup> , E <sup>5,6</sup>
III	—	A, B, C	A, B, C, D	A, B, C, D, E <sup>6</sup>

<sup>1</sup>When design pressure is over 1 MPa — only type A.  
<sup>2</sup>Including water, air, gases, non-combustible hydraulic oil.  
<sup>3</sup>Type B — only for pipes with nominal diameter of 150 mm and lower.  
<sup>4</sup>When design temperature exceeds 400 °C — only type A.  
<sup>5</sup>Types C, D and E (refer to Fig. 2.4.3.2) shall not be used when design temperature exceeds 250 °C.  
<sup>6</sup>For Type E the flanging technology shall be approved by the Register.

toxic and flammable media or media causing severe corrosive or erosive wear, as well as in conditions with heavy fatigue loads.

The threaded slip-on joints with taper thread may be applied in Class I pipelines with the diameter up to 33,7 mm and Class II and III pipelines with the diameter up to 60,3 mm.

Joints with parallel thread may be applied in Class III pipelines with the diameter up to 60,3 mm.

In particular cases, sizes in excess of those mentioned above may be accepted by the Register after special consideration if in compliance with the national or international standards.

**2.4.4.2** Application of threaded connections in CO<sub>2</sub> fire-extinguishing systems is allowed only inside the spaces to be protected and in CO<sub>2</sub> cylinders room.

#### 2.4.5 Mechanical joints.

**2.4.5.1** The present requirements are applicable to compression couplings, pipe unions and slip-on joints shown in Table 2.4.5.1. Application of such joints may be also accepted by the Register.

Due to the great variations in design and configuration of mechanical joints, no specific recommendation regarding calculation method for theoretical strength calculations is given in these requirements.

Type approval of the mechanical joints shall be based on the results of testing of their specimens.

**2.4.5.2** The application and pressure ratings of different mechanical joints shall be approved by the Register. The approval shall be based on the type tests in accordance with a program approved by the Register.

**2.4.5.3** Where the application of mechanical joints results in reduction in pipe wall thickness due to the use of bite type rings or other structural elements, this shall be taken into account in determining the minimum wall thickness of the pipe to withstand the design pressure.

**2.4.5.4** Material of mechanical joints shall be compatible with the piping material and internal and external media.

**2.4.5.5** Mechanical joints shall be tested where applicable, to a burst pressure of 4 times the design pressure.

For design pressures of 20 MPa and above, the required test pressure may be reduced.

**2.4.5.6** Where appropriate, mechanical joints shall be of fire resistant type as required by Table 2.4.5.11-1.

**2.4.5.7** Mechanical joints, which in the event of damage could cause fire or flooding, shall not to be used in piping sections directly connected to the ship's side below the bulkhead deck of passenger ships and freeboard deck of cargo ships or tanks containing flammable fluids.

Table 2.4.5.1  
Examples of mechanical joints

Pipe unions	
Welded and brazed types	
Compression couplings	
Swage type	
Press type	
Bite type	
Flared type	
Slip-on joints	
Grip type	
Machine grooved type	 Roll Groove
	 Cut Groove

Table 2.4.5.1 — continued



**2.4.5.8** The number of mechanical joints in flammable fluid systems shall be kept to a minimum. In general, flanged joints conforming to recognised standards shall be used.

**2.4.5.9** Piping in which a mechanical joint is fitted shall be adequately adjusted, aligned and supported. Supports or hangers shall not be used to force alignment of piping at the point of connection.

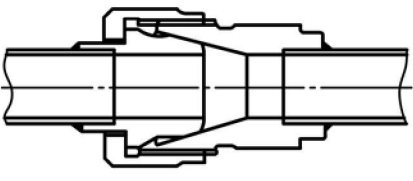
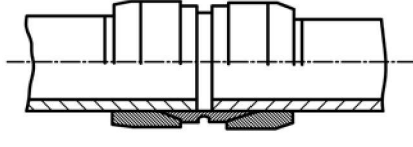
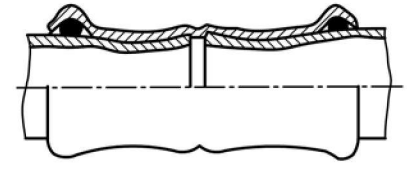
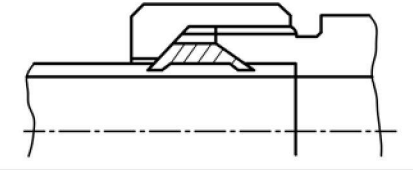
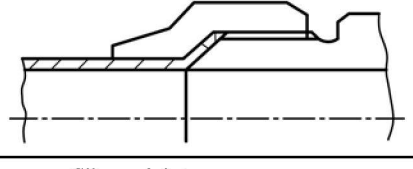
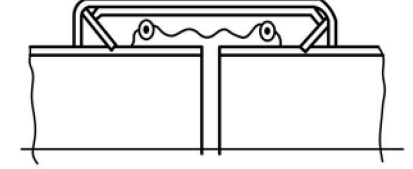
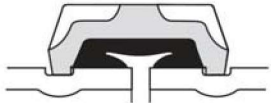
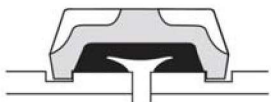
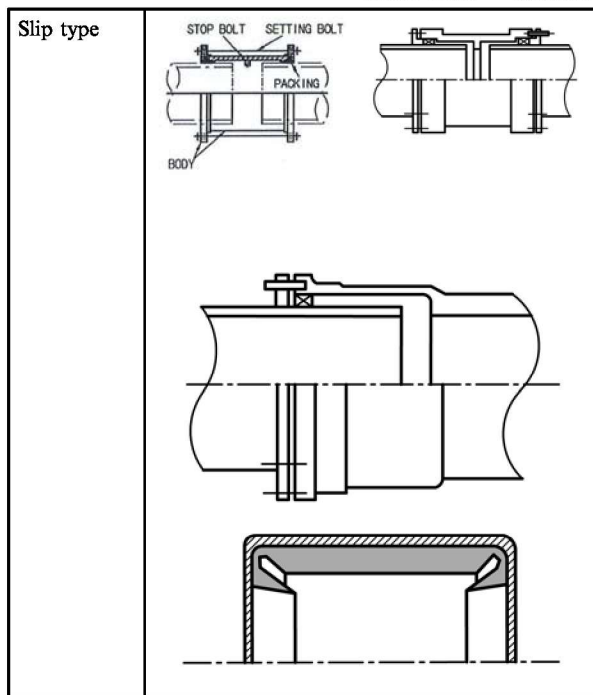
**2.4.5.10** Slip-on joints shall not be used in pipelines in cargo holds, tanks, and other spaces which are not easily accessible, unless approved by RS.

Application of these joints inside tanks may be permitted only for the same media that is in the tanks.

Usage of slip type slip-on joints as the main means of pipe connection is not permitted except for cases where compensation of axial pipe deformation is necessary.

**2.4.5.11** Application of mechanical joints and their acceptable use for each service is indicated in Table 2.4.5.11-1, dependence upon the Class of piping and pipe dimensions is indicated in Table 2.4.5.11-2.

**2.4.5.12** Mechanical joints shall be tested in accordance with a program approved by RS, which shall include at least the following:

- .1 leakage test;
- .2 vibration (fatigue) test;
- .3 fire endurance test (where necessary);

- .4 pressure pulsation test (where necessary);
- .5 vacuum test (where necessary);
- .6 burst pressure test (where necessary);
- .7 pull out test (where necessary);
- .8 assembly test (where necessary).

The scope and nature of tests shall be specified subject to the joint type and pipeline service.

**2.4.5.13** The installation of mechanical joints shall be in accordance with the manufacturer's assembly instructions. Where special tools and gauges are required for installation of the joints, these shall be supplied by the manufacturer.

## 2.5 FLEXIBLE HOSES

**2.5.1** Flexible hose is a short length of metallic or non-metallic hose normally with prefabricated end fittings ready for installation.

### 2.5.2 Application.

**2.5.2.1** The requirements 2.5.3 to 2.5.6 apply to flexible hoses of metallic or non-metallic material intended for permanent connection between a fixed piping system and items of machinery. The requirements may also be applied to temporary connected flexible hoses or hoses of portable equipment.

**2.5.2.2** Flexible hoses may be accepted for use in fuel oil, lubricating, hydraulic and thermal oil systems (cold portions), fresh water and sea water cooling systems, bilge and ballast systems, and Class III steam systems where they comply with 2.5.3 to 2.5.6. Flexible hoses in high-pressure fuel oil injection systems shall not be accepted.

**2.5.2.3** The present requirements are not applicable to hoses of water fire main system.

### 2.5.3 Design and construction.

**2.5.3.1** Flexible hoses shall be designed and constructed in accordance with the approved standards. Flexible hoses constructed of rubber and intended for use in bilge, ballast, compressed air, fuel oil, lubricating, hydraulic and thermal oil systems shall incorporate a single or double closely woven integral wire braid or other suitable material reinforcement.

Flexible hoses for the above use constructed of plastic materials such as teflon and nylon where integral wire braid is not allowed, shall have other suitable material reinforcement, if necessary.

Flexible hoses used as part of fuel oil pipes of oil burner units shall have external wire braid protection in addition to the above reinforcement. Flexible hoses for use in steam systems shall be of metallic construction.

**2.5.3.2** Flexible hoses shall be complete with approved end fittings. Except the flange connections, the end connections shall comply with the applicable

Table 2.4.5.11-1

## Application of mechanical joints depending on the pipeline service

Nos.	Systems	Kind of connections		
		Pipe unions	Compression couplings	Slip-on joints
Flammable fluids (flash point $\leq 60$ °C)				
1	Cargo oil lines <sup>1</sup>	+	+	+
2	Crude oil washing lines <sup>1</sup>	+	+	+
3	Vent lines <sup>2</sup>	+	+	+
Inert gas				
4	Water seal effluent lines	+	+	+
5	Scrubber effluent lines	+	+	+
6	Main lines <sup>1,3</sup>	+	+	+
7	Distribution lines <sup>1</sup>	+	+	+
Flammable fluids (flash point $> 60$ °C)				
8	Cargo oil lines <sup>1</sup>	+	+	+
9	Fuel oil lines <sup>2,3</sup>	+	+	+
10	Lubricating oil lines <sup>2,3</sup>	+	+	+
11	Hydraulic oil <sup>2,3</sup>	+	+	+
12	Thermal oil <sup>2,3</sup>	+	+	+
Sea water				
13	Bilge lines <sup>4</sup>	±	±	±
14	Water filled fire extinguishing systems, e.g. Sprinkler systems <sup>2</sup>	±	±	±
15	Non water filled fire extinguishing systems, e.g. foam, drencher systems <sup>2</sup>	±	±	±
16	Fire main (not permanently filled) <sup>2</sup>	±	±	±
17	Ballast system <sup>4</sup>	±	±	±
18	Cooling water system <sup>4</sup>	±	±	±
19	Tank cleaning services	±	±	±
20	Non-essential systems	±	±	±
Fresh water				
21	Cooling water system <sup>4</sup>	+	+	+
22	Condensate return <sup>4</sup>	+	+	+
23	Non-essential systems	+	+	+
Sanitary/drains/scuppers				
24	Deck drains (internal) <sup>5</sup>	+	+	+ <sup>1</sup>
25	Sanitary drains	+	+	+
26	Scuppers and discharge (overboard)	+	+	—
Sounding/vent				
27	Water tanks/Dry spaces	+	+	+
28	Fuel oil tanks (flash point $> 60$ °C) <sup>2,3</sup>	+	+	+ <sup>3,4</sup>
Miscellaneous				
29	Starting/Control air <sup>4</sup>	+	+	—
30	Service air (non-essential)	+	+	+
31	Brine	+	+	+
32	Carbon dioxide system <sup>4</sup>	+	+	—
33	Steam	+	+	+ <sup>6</sup>
<p>Symbols:  + application is allowed;  — application is not allowed.</p>				
<p>Footnotes: - Fire resistance capability  If mechanical joints include any components which readily deteriorate in case of fire, they shall be of an approved fire resistant type under consideration of the following footnotes:  <sup>1</sup>Only in pump rooms and open decks - only approved fire resistant types;  <sup>2</sup>Approved fire resistant types except in cases where such mechanical joints are installed on exposed open decks, as defined in 2.4.2 (10) of Part VI "Fire Protection" and not used for fuel oil lines;  <sup>3</sup>Not inside machinery spaces of category A or accommodation spaces. May be accepted in other machinery spaces provided the joints are located in easily visible and accessible positions;  <sup>4</sup>Inside machinery spaces of category A - only approved fire resistant types;  <sup>5</sup>Only above bulkhead deck of passenger ships and freeboard deck of cargo ships;  <sup>6</sup>Slip type slip-on joints may be used for pipes on deck with a design pressure of up to 1 MPa.</p>				

Table 2.4.5.11-2

Types of joints	Classes of piping systems		
	I	II	III
Pipe unions			
Welded and brazed type	+ (outside diameter $\leq 60,3$ mm)	+ (outside diameter $\leq 60,3$ mm)	+
Compression couplings			
Swage type	+	+	+
Bite type, flared type	+ (outside diameter $\leq 60,3$ mm)	+ (outside diameter $\leq 60,3$ mm)	+
Press type	—	—	+
Slip-on joints			
Machine grooved type	+	+	+
Grip type	—	+	+
Slip type	—	+	+
Symbols: + application is allowed; — application is not allowed.			

requirements of 2.4.5 and each type of hose/fitting combination shall be subject to prototype testing.

**2.5.3.3** The use of hose clamps and similar types of end attachments is not acceptable for flexible hoses in piping systems for steam, flammable media, starting air systems or for sea water systems where failure may result in flooding. In other piping systems, the use of hose clamps may be accepted where the working pressure is less than 0,5 MPa and provided there are double clamps at each end connection.

**2.5.3.4** Flexible hoses intended for installation in piping systems where pressure pulses or high levels of vibration are expected to occur in service, shall be designed for the maximum expected impulse peak pressure and forces due to vibration. The tests required by 2.5.5 shall take into consideration the maximum anticipated in-service pressures, vibration frequencies and forces due to installation.

**2.5.3.5** Flexible hoses constructed of non-metallic materials intended for installation in piping systems for flammable media and sea water systems where failure may result in flooding, shall be of fire-resistant type. Fire resistance is not required in cases where flexible hoses are installed on open decks, as defined in 2.2.1.5 (10) Part VI "Fire protection" and not used in fuel lines. Fire resistance shall be demonstrated by testing in accordance with the requirements of 2.5.5.6.

**2.5.3.6** Flexible hoses shall be selected for the intended location and application taking into consideration ambient conditions, compatibility with the conveyed fluids under working pressure and temperature conditions consistent with the manufacturer's instructions. Flexible hoses for use in fire

extinguishing systems shall comply with the requirement of 3.1.4.1.6, Part VI "Fire Protection".

#### **2.5.4 Installation.**

**2.5.4.1** In general, flexible hoses shall be limited to a length necessary to provide for relative movement between fixed and flexibly mounted items of machinery equipment or piping.

**2.5.4.2** Flexible hoses shall not be installed where they may be subjected to torsion deformation (twisting) under normal operation conditions.

**2.5.4.3** The number of flexible hoses in piping systems shall be kept to minimum and shall be limited for the purpose stated in 2.5.2.

**2.5.4.4** Where flexible hoses are intended to be used in piping systems conveying flammable fluids that are in close proximity of heated surfaces the risk of ignition due to failure of the hose assembly shall be mitigated by the use of screens or other similar protection to the satisfaction of the Register.

**2.5.4.5** Flexible hoses shall be installed in clearly visible and readily accessible locations.

**2.5.4.6** The installation of flexible hoses shall be in accordance with the manufacturer's instructions and use limitations with particular attention to the following:

- orientation (with consideration for allowable movement in service);
- end connection support (where necessary);
- avoidance of hose contact that could cause rubbing and abrasion;
- minimum bend radii.

#### **2.5.5 Tests.**

**2.5.5.1** Acceptance of flexible hoses is subject to satisfactory prototype testing. Prototype test programmes for flexible hoses shall be submitted by the manufacturer and shall be sufficiently detailed to

demonstrate performance in accordance with the specified standards.

**2.5.5.2** The tests shall be carried out on different nominal diameters of hose type complete with end fittings and shall incorporate tests in accordance with 2.5.5.3 to 2.5.5.6. Other standards may be accepted when agreed by the Register.

**2.5.5.3** Each flexible hose shall be tested by test pressure equal to 1,5 times the design pressure during 5 min. No residual deformations and damages are accepted.

**2.5.5.4** All flexible hoses shall be tested by burst pressure equal to four times the design pressure. Residual deformations without visible damages or leaks are accepted.

**2.5.5.5** Pressure impulse tests shall be carried out during prototype tests for flexible hoses intended for installation in systems where pressure impulses are expected. Pressure impulse tests shall be carried out to ISO 6802, ISO 6803, ISO 10380 or equivalent.

**2.5.5.6** Fire resistance tests shall be carried out during prototype tests of flexible hoses referred to in 2.5.3.5. The tests are carried out to ISO 15540 and ISO 15541 or equivalent.

#### **2.5.6 Marking.**

**2.5.6.1** Flexible hoses shall be permanently marked by the manufacturer with the following details:  
hose manufacturer's name or trademark;  
date of manufacture (month/year);

designation type reference;  
nominal diameter;  
pressure rating;  
temperature rating.

Where a flexible hose is made up of items from different manufacturers, the components shall be clearly identified.

## **2.6 CONNECTION GASKETS AND INSULATION MATERIALS**

**2.6.1** Containing asbestos materials shall not be used in pipelines. During survey of installation of systems and piping the documents, confirming the absence of asbestos in the materials of insulation and connection gaskets shall be submitted.

**2.6.2** The application of the rubber gaskets is allowed for systems and piping with the working medium temperature not more than 100 °C, fluoroplast — not more than 150 °C.

**2.6.3** If the material of a sealing element is a material that has no Type Approval Certificate (except for copper and copper-base alloys, as well as rubber and fluoroplast) the Register reserves the right to require the performance of chemical analysis of the sample of the sealing material.

### 3 PLASTIC PIPING

#### 3.1 DEFINITIONS

**3.1.1** For the purpose of the present Section, the following definitions have been adopted.

**Nominal pressure** is the maximum permissible working pressure as defined in 6.8.2.3, Part XIII "Materials".

**Fire resistance** is the ability of plastic pipeline to maintain strength and integrity (i.e. ability to operate to its designated purpose) within the set period of time under flame exposure.

**Plastic materials** are thermoplastic (thermoplasts) and thermosetting (thermosets) materials with or without reinforcement, such as polyvinylchloride (PVC) and fibre reinforced plastic (FRP). Plastic materials include caoutchouc and materials with similar thermomechanical behavior.

**Design pressure** is the maximum working pressure expected under operating conditions or the maximum pressure setting of the pressure-relief valve or pressure relieving device, if fitted.

**Joint** is the connection of pipes by glueing, application of binding bands, welding, etc.

**Piping/piping system** is a combination of plastic pipes, formed components, pipe joints and any internal or external coatings or linings necessitated by operating conditions.

**Formed components** are bends, elbows, connecting branches, etc. made of plastic.

#### 3.2 SCOPE OF APPLICATION. GENERAL REQUIREMENTS

**3.2.1** The present requirements apply to all pipelines made from plastics.

**3.2.2** The requirements are not applied to flexible non-metal joints, rubber hose, as well as to mechanical unions used in systems with metal pipes.

**3.2.3** General requirements to plastic pipes and fittings are stated in 6.8, Part XIII "Materials".

#### 3.3 REQUIREMENTS FOR PIPING DEPENDING ON THEIR PURPOSE AND LOCATION

##### 3.3.1 Fire-resistance.

**3.3.1.1** Pipes and formed components, integrity of which has significant influence on ship's safety, shall meet the requirements of fire-resistance.

**3.3.1.2** Depending on pipeline ability to maintain integrity during fire-resistance tests according to the procedure stated in IMO resolutions A.753(18) and MSC.313(88), five degrees of fire-resistance are specified:

**LI** for pipelines withstanding fire-resistance test in dry condition during 1 h without leakage during further hydraulic tests;

**W1** for pipelines not carrying flammable liquid or any gas and withstanding fire-resistance test in dry condition during 1 h with a maximum 5 per cent flow loss in the system;

**L2** for pipelines withstanding fire-resistance test in dry condition during 30 min without leakage during further hydraulic tests;

**W2** for pipelines not carrying flammable liquid or any gas and withstanding fire-resistance test in dry condition during 30 min with a maximum 5 per cent flow loss in the system;

**L3** for pipelines withstanding fire-resistance test in filled condition during 30 min without leakage during further hydraulic tests.

Plastic pipelines scope of application depending on fire-resistance degree, location and media conveyed is given in Table 3.3.1.2.

##### 3.3.2 Flame spreading, flame-retardant coatings.

**3.3.2.1** All pipes, with the exception of pipes located on weather decks, in tanks, in cofferdams, void spaces, pipelines tunnels, etc. shall obtain characteristic of slow spreading of flame on the surface, not exceeding the average values regulated by Part 5 of Annex 1 to the 2010 FTP Code. Piping materials shall fulfil the requirements of the International Code for Application of Fire Test Procedures (2010 FTP Code), annex 1, part 2, on smoke emission and toxicity test.

**3.3.2.2** When fire-retardant coatings are applied to provide the required degree of fire-resistance they shall comply with the requirements of 6.8, Part XIII "Materials".

**3.3.2.3** Fire-retardant coatings in junctions shall be applied after conducting of hydraulic tests of the system in compliance with pipe manufacturer recommendations according to the procedure approved by the Register in each case.

**3.3.2.4** Fire-retardant coatings shall be used according to the approved recommendations of the manufacturer.

Table 3.3.1.2

## Application of plastic pipelines

Nos	Medium to be conveyed	Location											
		Piping systems	A	B	C	D	E	F	G	H	I	J	K
1	Liquid cargoes with flash point ≤60 °C	Cargo	—	—	L1	—	—	O	—	O <sup>1</sup>	O	—	L1 <sup>2</sup>
		Crude oil tank washing	—	—	L1	—	—	O	—	O <sup>1</sup>	O	—	L1 <sup>2</sup>
		Exhaust gas	—	—	—	—	—	O	—	O <sup>1</sup>	O	—	+
2	Inert gas	Pipeline from hydraulic lock	—	—	O <sup>3</sup>	—	—	O <sup>3</sup>	O <sup>3</sup>	O <sup>3</sup>	O <sup>3</sup>	—	O
		Pipeline from purifier	O <sup>3</sup>	O <sup>3</sup>	—	—	—	—	—	O <sup>3</sup>	O <sup>3</sup>	—	O
		Main pipe	O	O	L1	—	—	—	—	—	O	—	L1 <sup>4</sup>
		Distribution pipelines	—	—	L1	—	—	O	—	—	O	—	L1 <sup>2</sup>
3	Flammable liquids with flash point >60 °C	Cargo	+	+	L1	+	+	— <sup>5</sup>	O	O <sup>1</sup>	O	—	L1
		Fuel oil	+	+	L1	+	+	— <sup>5</sup>	O	O	O	L1	L1
		Oil	+	+	L1	+	+	—	—	—	O	L1	L1
		Hydraulic	+	+	L1	+	+	O	O	O	O	L1	L1
4	Sea water	Drainage	L1 <sup>6</sup>	L1 <sup>6</sup>	L1	+	+	—	O	O	O	—	L1
		Drain pipelines of internal spaces	W1 <sup>7</sup>	W1 <sup>7</sup>	—	W1 <sup>7</sup>	O	—	O	O	O	O	O
		Sanitary drains (internal)	O	O	—	O	O	—	O	O	O	O	O
		Drainage from weather decks	O <sup>3,8</sup>	O <sup>3,8</sup>	O <sup>3,8</sup>	O <sup>3,8</sup>	O <sup>3,8</sup>	O	O	O	O	O <sup>3,8</sup>	O
		Firemain system and water spraying	L1	L1	L1	+	—	—	—	O	O	+	L1
		Foam fire-extinguishing	W1	W1	W1	+	—	—	—	O	O	W1	W1
		Sprinkling	W1	W1	L3	+	—	—	—	O	O	L3	L3
		Ballast	L3	L3	L3	L3	+	O <sup>1</sup>	O	O	O	W2	W2
		Essential purpose cooling systems	L3	L3	—	—	—	—	—	O	O	—	W2
		Non-essential purpose cooling systems	O	O	O	O	O	—	O	O	O	O	O
Crude oil tank washing	—	—	L3	—	—	O	—	O	O	—	L3 <sup>2</sup>		
5	Fresh water	Essential purpose cooling systems	L3	L3	—	—	—	—	O	O	O	L3	L3
		Condensate return system	L3	L3	L3	O	O	—	—	—	O	O	O
		Non-essential purpose systems	O	O	O	O	O	—	O	O	O	O	O
6	Other media	Air, sounding and overflow pipes: water tanks and dry compartments	O	O	O	O	O	O <sup>1</sup>	O	O	O	O	O
		Flammable liquids, $T_{flash} > 60$ °C	+	+	+	+	+	+	O	O <sup>1</sup>	O	+	+
		Pneumatic control systems	L1 <sup>9</sup>	L1 <sup>9</sup>	L1 <sup>9</sup>	L1 <sup>9</sup>	L1 <sup>9</sup>	—	O	O	O	L1 <sup>9</sup>	L1 <sup>9</sup>
		Air pipes for domestic needs	O	O	O	O	O	—	O	O	O	O	O
		Brine	O	O	—	O	O	—	—	—	O	O	O
		Low pressure steam	W2	W2	O <sup>10</sup>	O <sup>10</sup>	O <sup>10</sup>	O	O	O	O	O <sup>10</sup>	O <sup>10</sup>

## Symbols:

- A — machinery spaces of category A;  
 B — other machinery spaces;  
 C — cargo pumps rooms, including accesses and trunks;  
 D — cargo spaces of roll-on/roll-off ships;  
 E — dry cargo rooms and trunks;  
 F — cargo tanks and trunks;  
 G — fuel oil tanks and trunks;  
 H — ballast tanks and trunks;  
 I — cofferdams, dry compartments, etc;  
 J — accommodation, service spaces and control stations;  
 K — weather decks;  
 L1 — fire-resistance test in dry condition during 60 min;  
 L2 — fire-resistance test in dry condition during 30 min;  
 L3 — fire-resistance test in filled condition during 30 min;  
 O — fire-resistance test is not required;  
 "—" — not applicable;  
 "+" — only metal materials with fusion point above 925 °C.

<sup>1</sup>For tankers, where the requirements of item 3.6, Regulation 19 of Annex I to MARPOL 73/78 shall be met, "—" shall be used instead of "O".

<sup>2</sup>For cargo tanks the remotely closing valves shall be provided.

<sup>3</sup>From the side the valves with remote control located outside of the room shall be provided.

<sup>4</sup>For pipeline between engine room and deck hydraulic lock "O" may be used instead of "L1".

<sup>5</sup>When cargo tanks contain flammable liquids with flash point >60 °C, "O" may be used instead of "—" or "+".

<sup>6</sup>For passenger ships "+" shall be used instead of "L1".

<sup>7</sup>For drainage pipelines servicing only the particular space "O" may be used instead of "L1".

<sup>8</sup>Scupper holes of weather decks in the positions 1 and 2 according to Regulation 13 of the International Convention on Load Line, 1966, shall be "+", if they are not provided with the appropriate blanking means.

<sup>9</sup>When control functions are not foreseen, "O" may be used instead of "L1".

<sup>10</sup>For essential purposes, such as heating of cargo tanks and ship's typhon, "+" shall be used instead of "O".

### 3.4 INSTALLATION REQUIREMENTS

#### 3.4.1 Supports.

3.4.1.1 Choice of supports and distances between them shall be determined depending on permissible stresses and maximum allowable pipe swag.

Distances between supports shall not exceed the values recommended by the manufacturer.

In selection of supports and distances between them pipes sizes, mechanical and physical properties of pipe material, mass of pipes and liquid containing in them, external pressure, working temperature, influence of heat expansion, load of outer forces, axial forces, hydraulic impact, vibration, which may occur in the system, shall be taken into consideration. Allowance shall be made for the possible simultaneous effect of the above mentioned loads.

3.4.1.2 The load from pipe weight shall be equally distributed over the entire load-bearing face of the support. Measures shall be taken to minimize pipe wearing in the points of their junction with the supports.

3.4.1.3 Components of system having significant mass, such as valves, compensators, etc. shall be fitted with separate supports.

#### 3.4.2 Heat expansion compensation.

3.4.2.1 When assembling of plastic pipelines the compensation tolerance for relative displacement between piping and steel structures with regard to difference in heat expansion ratio and ship's hull deformation shall be provided.

3.4.2.2 When calculating heat expansions the working temperature of system and the temperature, at which assembling is carried out, shall be taken into account.

#### 3.4.3 Environmental stresses.

3.4.3.1 In pipe laying, where necessary, allowance shall be made for periodically involved concentrated loads. At least, the force generating by the load of one person of 100 kg in the middle of span of any pipe with the outer diameter over 100 mm shall be taken into consideration.

3.4.3.2 To ensure the appropriate rigidity of piping, including pipelines with open ends, the Register may require to increase the wall thickness in comparison with thickness specified on the basis of strength control.

3.4.3.3 When necessary, pipes shall be protected from mechanical damage.

#### 3.4.4 Installation of electrically conducting pipes.

3.4.4.1 In systems of liquids transmission with electrical conductivity less than 1000 pico-siemens per meter (PS/m), such as raffinates, distillates, the electrically conductive pipes shall be used.

3.4.4.2 Regardless of the liquids transmitted the plastic pipes passing through explosive areas shall be electrically conductive.

Resistance in any point of pipeline system as relative to earth shall not exceed  $10^6$  Ohm. Pipes and formed components having electrically conducted layers shall preferably be of equal conductivity.

Such pipes shall be sufficiently protected from damage by electric discharge caused by difference in the electrical conductivity of layers.

3.4.4.3 After installation earth connection shall be checked. Earthing wires shall be accessible for examination.

### 3.5 PLASTIC PIPES JOINTS

#### 3.5.1 Strength of joints.

3.5.1.1 Strength of joints shall not be less than strength of a pipeline where they are mounted.

3.5.1.2 Pipes may be connected with the use of glued, welded, flanged and other connections.

3.5.1.3 Glues used for pipes joints shall keep tightness of joints in the whole pressure and temperature range.

3.5.1.4 Tightening of joints shall be carried out in compliance with the instructions of the manufacturer.

#### 3.5.2 Testing of joints quality.

3.5.2.1 For the inspection of pipe joint quality it is necessary in accordance with the accepted procedure to prepare test assemblies, which shall include at least one joint of pipe with pipe and pipe with formed component.

3.5.2.2 Following joint setting, a test connection shall be subjected to a hydraulic pressure test during at least 1 hour at the pressure 2,5 times exceeding the design one. Leakage and breaks of joint are not allowed. Tests shall be arranged in such a way that joints are loaded both in longitudinal and transverse directions.

3.5.2.3 When selecting pipes for test specimen the following shall be taken into consideration:

when the maximum outer diameter of joint assembly is less than 200 mm, the test assembly shall incorporate a pipe with the maximum diameter;

when the maximum outer diameter of joint assembly is over 200 mm, the outer diameter of test joint assembly shall be 200 mm or shall be equal to 25 per cent of the maximum diameter of the coupling, whatever is greater.

### 3.6 PLASTIC PIPING LAYING

3.6.1 Where plastic pipes pass through watertight bulkheads and decks, "A" and "B" class divisions the requirements of 5.1 shall be met.

**3.7 INSPECTION DURING THE INSTALLATION**

**3.7.1** Installation shall be carried out in accordance with the instructions of the manufacturer.

**3.7.2** The method of pipe connection (junction) shall be developed and approved prior to the installation.

**3.7.3** Surveys and tests stated in the present Section of the Rules shall precede the approval of the method.

**3.7.4** Personnel involved in the works shall be properly qualified and attested.

**3.7.5** In the method of joints connection the following shall be reflected: the applied materials, tools and accessories, the requirements on preparation of joints, temperature conditions, the requirements on dimensions and tolerances, as well as the acceptance criteria upon the work and testing completion.

**3.7.6** Any alterations in the method resulting in change of physical and mechanical properties of the joint call for its repeated consideration and re-approval.

**3.8 TESTING OF PIPING AFTER INSTALLATION  
ABOARD THE SHIP**

**3.8.1** After installation the pipeline system of essential purpose shall be hydraulically tested with pressure at least 1,5 times higher than the design pressure.

**3.8.2** The pipeline system of non-essential purpose may be tested for tightness with the working pressure.

**3.8.3** For electrically conductive pipes the availability of grounding shall be checked and the spot check of resistance shall be carried out.

## 4 VALVES

### 4.1 CONSTRUCTION, MARKING, ARRANGEMENT AND INSTALLATION OF VALVES

#### 4.1.1 Construction.

4.1.1.1 Valves shall comply with the agreed standards. Valve threaded covers shall be fitted with reliable stops.

4.1.1.2 Valves with remote control shall be arranged for local manual operation independent of the remote operating mechanism or they shall be operated from a separate monitor console with tracker-balls and power supply to control valves from independent source, or it is provided with manual operation both directly where fitted and using manual remote control.

The remotely controlled valves shall be so constructed that in case of failure of the remote control system, the valves remain, or automatically return, in a position that will not bring the ship in dangerous situation.

4.1.1.3 Compressed air shall not be used in remote control systems to operate actuators inside cargo tanks.

4.1.1.4 Where the valves inside cargo tanks are remote-controlled by means of a hydraulic system, they shall be also operable with the aid of a hand pump, which can be connected to the hydraulic system in positions where the pipes are laid down to each valve, or to a separate pipe laid directly to the valve actuator.

4.1.1.5 The supply tank of the hydraulic remote control system of the valves inside cargo tanks shall be located as high as practicable above the level of the top of cargo tanks, and all supply pipes shall enter the cargo tanks through the highest part of the cargo tanks.

The supply tank shall also have an air pipe laid to a safe position on the open deck and fitted with a flame-arresting gauze at the open end.

This tank shall be fitted with a low level audible and visual alarm.

#### 4.1.2 Marking of valves.

4.1.2.1 The shut-off valves shall be provided with conspicuous nameplates fixed in place and bearing clear inscriptions to show the purpose of valves.

4.1.2.2 At the control stations, the remote-controlled valves shall have identification plates, as well as position indicators "open" and "closed".

Where the remote control is used only to close the valves, the indicators need not be fitted.

#### 4.1.3 Installation of valves.

4.1.3.1 The valves arranged on watertight bulkheads shall be secured to welded pads by studs, or to

bulkhead sockets with flange connections. Joints of types "D" and "E" (refer to 2.4.3.2) are not allowed.

The stud holes shall not be through holes.

4.1.3.2 The valve chests and the hand-controlled valves shall be fitted in places where they are at all times readily accessible in normal operating conditions.

Where the valves of the fuel oil system are installed in the machinery space, the valve control gear shall be fitted above the plating.

4.1.3.3 The measuring instruments of fuel oil and lubricating oil systems shall be provided with valves or cocks to shut the instruments off from piping. Thermometer sensors shall be fitted in compact sleeves.

### 4.2 FILTERS

4.2.1 The design and construction of filters shall facilitate cleaning.

4.2.2 Filters shall be provided with a device to indicate the absence of pressure therein before they are opened.

The tubes of such devices shall be directed to trays so that spillages are not sprayed around.

4.2.3 For filters forming part of systems with a combustible working medium, an interlock is recommended so that they cannot be opened when under pressure and that the working medium cannot be supplied therein when opened.

4.2.4 Filters shall be so arranged that they are readily accessible for maintenance.

Filters and strainers forming part of systems with a combustible working medium shall be located as far away as practicable from sources of ignition.

4.2.5 The pipelines used to supply and carry away fuel oil in/from the filters shall be equipped with shut-off valves or cocks.

4.2.6 Filters on seawater suction mains shall comply with 15.3.1.

### 4.3 SEA CHESTS AND ICE BOXES. BOTTOM AND SIDE VALVES. OPENINGS IN SHELL PLATING

#### 4.3.1 Sea chests and ice boxes.

4.3.1.1 Number and arrangement of sea chests for the cooling water system shall comply with 15.2.1. In *Arc4* and *Arc5* ice class ships one of the sea chests shall function as an ice box. In icebreakers and *Arc6* to *Arc9* ice class ships, at least two sea chests shall be ice boxes.

In icebreakers and Arc4 to Arc9 ice class ships the ice box design shall allow for an effective separation of ice and removal of air from the ice box to ensure reliable operation of the sea-water system.

Sea inlet valves shall be secured directly to sea chests or ice boxes.

**4.3.1.2** In icebreakers and ice class ships, provision shall be made for the heating of the sea chests and ice boxes as well as of the ship side valves and fittings above the load waterline. For this purpose:

cooling water recirculation shall be used for ice boxes and sea chests;

ship side valves and fittings shall be supplied with heating medium through a non-return shut-off valve. The heating arrangements shall be so designed as to prevent the side valves and fittings and shell plating from being damaged under the influence of lowest temperatures.

Electric heating systems with special heating cables may be used for valves heating. When using a heating cable, the requirements of 5.8 shall be complied with.

For ice boxes the recirculated water pipes shall be laid to the upper and lower part of the box, and the total sectional area of these pipes shall not be less than the area of the cooling water discharge pipe.

For sea chests, the diameter of the water recirculating pipe shall not be less than 0,85 of the discharge pipe diameter.

**4.3.1.3** Provision shall be made for the access into these boxes via detachable gratings or manholes. If a manhole is provided in the ice box it shall be located above the deepest load line.

**4.3.2 Openings in shell plating. Bottom and side valves.**

**4.3.2.1** The number of openings in shell plating shall be kept to a minimum. Therefore, wherever possible, discharge pipes shall be connected to common discharges.

**4.3.2.2** The location of sea inlet and discharge openings in ship sides shall be such as to prevent:

.1 sewage, ash and other wastes being sucked by sea water pumps;

.2 sewage and discharge water penetrating into the ship spaces through side scuttles as well as any discharge of water into lifeboats and liferafts when lowered.

Where it is impracticable to comply with the requirements of 4.3.2.2.2, discharge openings shall be fitted with appropriate arrangements to prevent the ingress of water into ship spaces, lifeboats and liferafts.

**4.3.2.3** All the openings in ship side for sea chests and ice boxes shall be fitted with gratings. Instead of

gratings, holes or slots in shell plating are permissible. The net area through the gratings or slots shall not be less than 2,5 times the area of the valve connected to the sea inlet. The diameter of holes and the width of slots in ratings or shell plating shall be about 20 mm. The gratings of the sea chests shall be provided with a steam or compressed air connection for clearing purposes. For ice boxes, clearing arrangements are not compulsory.

Clearing pipes shall be provided with non-return shut-off valves. The pressure of steam or compressed air in the clearing system shall not exceed 0,5 MPa.

**4.3.2.4** The overboard discharges from enclosed spaces below the freeboard deck or from enclosed superstructures and deckhouses on the freeboard deck shall be fitted with accessible means for preventing water from passing inboard. Discharges from piping, which have, or may have, open ends within the mentioned spaces shall comply with the requirements of 3.2.11, Load Line Rules for Sea-Going Ships.

**4.3.2.5** In ships of less than 24 m in length, openings in shell plating of spaces on and below the freeboard deck may have one locally controlled non-return shut-off valve.

In floating docks, each discharge of pipes from spaces below the margin line, which have inboard ends in those spaces, shall have a non-return valve with a positive means of closing from a readily accessible position above the safety deck.

**4.3.2.6** The scuppers and overboard discharge pipes from open decks and spaces not specified in 4.3.2.4 either 450 mm below the freeboard deck or less than 600 mm above the summer load waterline shall be fitted with non-return valves (dampers) at the outer shell. In this case, the wall thickness of scuppers and discharge pipes shall not be less than stated in column 3 of Table 2.3.8.

No valves may be provided if the wall thickness of pipes below the freeboard deck and in spaces within enclosed superstructures is less than:

7 mm for  $d \leq 80$  mm;

10 mm for  $d = 180$  mm;

12,5 mm for  $d \geq 220$  mm

where  $d$  = external diameter of pipes.

Intermediate sizes shall be determined by linear interpolation.

In open superstructures and deckhouses, overboard scuppers shall be provided.

In spaces intended for the carriage of motor vehicles with fuel in their tanks, overboard scupper pipes shall be provided to prevent accumulation of water during the operation of the water spraying system.

In floating docks, the overboard scuppers and discharge pipes below the margin line from spaces

above the margin line and open decks shall have non-return valves at the outer shell. The valves may be omitted where the pipe thickness below the margin line is not less than that of the outer shell plating, however, it need not exceed 12 mm.

**4.3.2.7** In engine rooms, the sea inlets and discharges of the systems and piping in connection with the operation of the main and auxiliary machinery shall be provided with readily accessible shut-off valves locally or remotely controlled. The controls shall be provided with indicators showing whether the valve is open or closed. The discharge valves, as a rule, shall be of the non-return shut-off type.

**4.3.2.8** The controls of inlet bottom and side valves shall be readily accessible and shall be provided with an indicator showing whether the valve is open or closed.

In passenger ships, these controls shall be located above the floor level of the engine room.

**4.3.2.9** In periodically unattended machinery spaces the location of the controls of any valve serving a sea inlet, a discharge below the waterline or a bilge injection system shall be so sited as to allow the time taken for the influx of water resulting from damage of piping related with the said valves to reach the control be greater than the time to reach and operate the control with the nominal speed of travel of a person onboard not more than 1 m/s. In any case, the time taken for the influx of water to reach the control shall be not less than 10 min.

If the level, to which a space can be flooded with the ship in the fully loaded condition, is above the controls, provision shall be made to operate them from a position above this level.

Machinery spaces fully automated in respect of control of sea inlet and discharge valves of the main and auxiliary machinery systems and piping shall be regarded equal to attended machinery spaces on condition that the provision is made of arrangements, activating when the space is being flooded.

**4.3.2.10** Bottom and side valves shall be attached to welded pads.

The stud holes shall not penetrate the shell plating and shall be only within the welded pads.

The valves may be also installed on branch pipes welded to the shell plating, provided they are straight, rigid enough and have the minimum length and cathodic protection against contact corrosion. Branch pipes shall be located in readily accessible places for maintenance and for measuring of shell plating thickness under service conditions. The use of flanged joints of D and E types (refer to 2.4.3.2), thread and me-chemical joints to install bottom and side valves below the waterline is not allowed.

For cooling systems of main or auxiliary machinery the wall thickness of a branch pipe at least 12 mm thick. In systems, used for pumping periodically, as well as in blow-off systems thickness of side branch pipes may be taken in accordance with 4.3.2.6.

**4.3.2.11** As a rule, the bottom and side valves shall be of flanged type. Valves of other types may also be allowed provided that the attachment of the bottom and side valves to hull structures ensures their operability and watertightness of the hull when a piping section adjacent thereto is dismantled. The material of the seal between the bottom and side valves and the hull shall not be easily deteriorated in case of fire, or special structural measures shall be taken to prevent deterioration of the seal.

**4.3.2.12** The spindles and movable parts of bottom and side valves shall be manufactured of corrosion-resistant materials. Protection against contact corrosion shall be provided in accordance with 1.4.3.4.

**4.3.2.13** The shell openings from garbage chutes of spaces located below the freeboard deck shall be provided with closing devices for preventing water from passing inboard. The closing devices shall meet the requirements of 3.2.11.1 of the Load Line Rules for Sea-Going Ships.

#### 4.4 AIR PIPE AUTOMATIC CLOSING DEVICES

**4.4.1** Air pipe automatic closing devices shall be self-draining have reliable attachments, and shall also:

- .1 prevent the free entry of water into the tanks;
- .2 allow the passage of air or liquid to prevent excessive pressure or vacuum coming on the tank.

**4.4.2** Air pipe automatic closing device shall be constructed to allow inspection of the inside of the casing, as well as changing the seals.

**4.4.3** Efficient float seating arrangements shall be provided for the closures. Besides seating arrangements other means shall be provided to prevent the float from contacting the inner chamber in its normal state and to prevent the float damage from the water impact in case the tank is overfilled.

**4.4.4** The clear area through an air pipe automatic closing device in the open position shall be at least equal to the area of the inlet.

**4.4.5** Air pipe automatic closing devices shall be so suitable for use at inclinations up to 40°.

**4.4.6** In the case of air pipe automatic closing devices of the float type, suitable guides shall be provided to ensure unobstructed operation under all working conditions of heel and trim.

**4.4.7** The maximum allowable tolerances for wall thickness of floats shall not exceed 10 per cent of thickness.

**4.4.8** The inner and the outer chambers of an automatic air pipe head shall be of a minimum thickness of 6 mm. Where side covers are provided and their function is integral to providing functions of the closing device as outlined in 4.4.1, they shall have a minimum wall thickness of 6 mm. If the air pipe head can meet the tightness test in 21.4.1.2, without the side covers attached, then the side covers shall not be considered integral to the closing device, in which case a wall less than 6 mm can be acceptable for side covers.

Casings of air pipe closing devices shall be of approved metallic materials adequately protected against corrosion. For galvanized steel air pipe heads, the zinc coating is to be applied by the hot method and the thickness is to be 70 to 100 microns.

**4.4.9** For areas susceptible to erosion due to the ballast water impact when the tank is being over-filled, (e.g. the inner chamber area above the air pipe, overlap of  $\pm 10^\circ$  either side) an additional harder coating shall be applied. This shall be an aluminum bearing epoxy, or other equivalent, coating, applied over zinc.

**4.4.10** Elements of closures made of non-metallic materials shall be compatible with the media carried in the tank and suitable for operating at ambient temperatures between  $-25^\circ\text{C}$  and  $+85^\circ\text{C}$ .

**4.4.11** Air pipe automatic closing devices shall be type approved and the minimum test requirements shall be in compliance with 21.4.

## 5 PIPING LAYING

### 5.1 PIPING LAYING THROUGH WATERTIGHT AND FIRE-PROOF DIVISIONS

**5.1.1** The number of pipelines passing through the watertight bulkheads shall be kept to a minimum.

Pipelines passing through main watertight bulkheads, shall, as a rule, be situated at a distance from the ship's side of at least one-fifth of the ship's breadth (refer to 7.3.5).

Where this requirement is impracticable, measures shall be taken to prevent the spread of sea water beyond the damaged compartment into other watertight compartments and tanks in case of damage to the ship's hull and deterioration of pipes.

**5.1.2** In cargo ships of 80 m in length and more and in passenger ships irrespective of their length the collision bulkhead may be pierced below the bulkhead deck by not more than one pipe for dealing with liquid in the forepeak tank. This pipe, at its piercing the collision bulkhead, shall be fitted with a screw-down valve directly on the collision bulkhead inside the forepeak capable of being operated from a readily accessible place above the bulkhead deck. Such valve may be fitted on the after side of the collision bulkhead provided that the valve is readily accessible under all service conditions and the space in which it is located is not a cargo space. Fitting of a butterfly valve instead of a screw-down valve is not allowed. If the forepeak is divided by a longitudinal bulkhead into two watertight compartments to hold two different kinds of liquids, the collision bulkhead may be allowed to be pierced below the bulkhead deck by two pipes, each of which is fitted with such valve.

On pipes piercing the collision bulkhead above the bulkhead deck or freeboard deck a screw-down valve may be omitted.

**5.1.3** In cargo ships not mentioned in 5.1.2 each pipe piercing the collision bulkhead below the bulkhead deck shall be fitted with a screw-down valve directly on the collision bulkhead inside the forepeak. Such valve shall be capable of being operated from a readily accessible place above the bulkhead deck for ships having the subdivision mark in the class notation, or above the freeboard deck for other ships. Such valve may be fitted on the after side of the collision bulkhead, provided that the space in which it is located is not a cargo space.

**5.1.4** Where pipelines pass through watertight bulkheads, decks and other watertight structures, there shall be used appropriate bulkhead (sockets), welded pads and other details to ensure the integrity of the structure concerned.

The holes for studs shall not penetrate through the plating of watertight structure and shall be kept within the welded pads.

Gaskets made of lead or a material, which will be readily deteriorated in the event of fire, shall not be used.

Sockets attached by welding to watertight decks and bulkheads shall have the wall thickness not less than wall thickness of attached pipes.

The bulkhead sleeves or sockets for pipes penetration through the watertight decks and bulkheads shall be attached by butt, full-penetration welding. Use of lap or fillet welds may be allowed if the integrity is ensured by two welds (on both sides of the bulkhead).

**5.1.5** Where plastic pipes pass through watertight bulkheads and decks forming boundaries of watertight compartments, valves capable of being operated from above the bulkhead deck shall be fitted.

The valves shall be of steel or another material equivalent to steel in fire resistance.

This requirement does not apply to ballast pipes laid within the double bottom.

**5.1.6** Where it is necessary to carry pipes through fire-resisting divisions, the requirements of 2.1.3.3, Part VI "Fire Protection" shall be complied with.

**5.1.7** Where plastic pipe passes through a division of the main vertical fire zone, provision shall be made for bulkhead steel sleeve and valve that may be closed from either side of the bulkhead. The valve shall be of steel or another material equivalent to steel in fire resistance.

**5.1.8** In the arrangement of penetration and sealing of pipe bundle through the bulkhead sockets in watertight bulkheads and decks use shall be made of sealing and sealing masses having good adhesion with the pipe and socket metal, resistant to vibration and to water and oily products, which do not shrink and do not cause loss of sealing during prolonged operation under conditions specified in 2.3.1, Part VII "Machinery Installations". The sealing of the pipe bundle penetration through the fireproof bulkheads shall be such as to withstand standard fire test specified for the bulkhead of this type in 2.1.2.2, Part VI "Fire Protection".

### 5.2 PIPING LAYING IN TANKS

**5.2.1** Bilge pipes, drinking water and feed water pipes shall not be laid through fuel oil and lubricating oil storage tanks, nor shall fuel oil and lubricating oil pipes pass through drinking water and boiler feed

water tanks, unless the pipes are laid in oiltight ducts forming part of the tank structure.

Sea water and lubricating oil piping, with no ducts as well as air, overflow and sounding pipes may pass through the fuel storage tanks, if these pipes are of seamless type and have no detachable joints inside the storage tanks; where detachable joints cannot be avoided, they shall be flanged with oilproof gaskets placed between them or compression couplings according to Table 2.4.5.1.

**5.2.2** Where the pipes passing through the tanks are not carried in ducts and thermal expansion shall be considered, pipe bends shall be arranged inside the tank.

Where pipes are laid in ducts, it is recommended that thermal compensators be arranged outside the duct.

**5.2.3** The pipes laid in oil tankers shall comply with the requirements of 9.2.

### 5.3 PIPING LAYING IN CARGO HOLDS AND OTHER SPACES

**5.3.1** Pipes shall be secured in a way as not to interfere with the stresses from thermal expansion, undue deformation of ship structure and vibration.

**5.3.2** Pipes passing through cargo holds, chain lockers and other spaces, in which they are subject to mechanical damage, shall be adequately protected.

**5.3.3** Fuel, steam and water pipes as well as pressure pipes of the hydraulic drives shall not, as a rule, be carried in dry cargo holds. Bilge pipes are excluded from this requirement.

These pipes may be allowed, provided they are laid in special ducts or not in ducts where the pipes employed are of increased thickness and protected by strong steel casings.

**5.3.4** Steam pipes shall not be laid in paint room, lantern room or other spaces intended for the carriage of readily flammable materials.

**5.3.5** Pipes conveying fuel oil shall not be laid through the accommodation and service spaces as well as under the coating, with the exception of fuel pipe of the emergency diesel-generator and the filling pipes, which are allowed to be laid through sanitary spaces, provided the pipes used have a thickness of not less than 5 mm and no detachable joints are employed.

**5.3.6** Pipes having considerable longitudinal extension and conveying hot media shall have thermal compensators or as many bends as will provide adequate self-compensation of the pipeline.

Thermal compensators are fitted in order to take up the axial and transverse displacements and shall not be used to correct misalignment of the pipes. Pipelines shall have appropriate supports. Brackets

and hangers shall not be used to produce forces that provide alignment of the pipes or elements.

The radii of bends shall be in compliance with 2.2.1.

**5.3.7** The pipes of all the systems and the vent ducts shall, where necessary, be fitted with arrangements for blow-down of the working medium or draining of liquid, if any.

Appropriate structural measures shall be taken to protect ship's hull and equipment from adverse effect of the agents discharged.

**5.3.8** The pipes of fire fighting system shall be laid in conformity with the requirements of 3.1.4.1, Part VI "Fire Protection".

**5.3.9** Group I and II refrigerant piping laying through accommodation and service spaces shall be carried out in compliance with 6.2.8, Part XII "Refrigerating Plants".

### 5.4 PIPING LAYING IN REFRIGERATED CARGO SPACES

**5.4.1** It is recommended that no pipes be laid through refrigerated cargo spaces, unless they are intended to serve these spaces. Where laying of such pipes cannot be avoided, they shall be carefully insulated. This requirement equally applies to air and sounding pipes. In these spaces the pipes shall not have sections, in which water may collect and freeze.

### 5.5 PIPING LAYING IN THE VICINITY OF ELECTRICAL AND RADIO EQUIPMENT

**5.5.1** Pressure pipes are not permitted to be laid above and behind the main and emergency switchboards as well as the control panels of essential machinery and equipment.

Piping may be laid at a distance of not less than 500 mm from the fronts and sides of the switchboards and control panels, provided that at a distance of 1500 mm to the switchboards and panels and along them no detachable joints are used on piping or the joints have protective casings.

**5.5.2** Pipes shall not be laid either through special electric spaces (refer to 1.2, Part XI "Electrical Equipment"), or through accumulator battery rooms, with the exception of fire carbon dioxide smothering system pipes, compressed air pipes and pipes serving the electrical equipment installed in these spaces. Other pipes are allowed to be laid through such spaces when the requirements of 5.5.1 are fulfilled and provided there is no valves or detachable joints. Where necessary measures for protection of the pipes against condensate formation shall be applied.

**5.5.3** Laying of pipes through the space containing the gyrocompass is not allowed, with the exception of cooling pipes for gyrocompass.

**5.5.4** Laying of pipes through the radiator room is not allowed.

#### **5.6 PIPING LAYING IN UNATTENDED MACHINERY SPACES**

**5.6.1** Class I pipes conveying fuel oil and lubricating oil shall have welded joints. Detachable joints are permitted to be used, but their number shall be kept to a minimum; if considered necessary, protective casings shall be provided in places where detachable joints are fitted.

#### **5.7 PIPING LAYING IN SHIPS WITH TWIN HULLS**

**5.7.1** When routed along the common upper deck, the pipes connecting identical systems of both hulls shall be provided with compensators where necessary and protected against damage.

Damage to these pipes shall not involve failure of the systems connected by them.

#### **5.8 PIPELINES WITH ELECTRIC HEATING**

**5.8.1** Electrical equipment in systems incorporating pipelines provided with electric heating shall meet the requirements of 15.4.3 to 15.4.6, Part XI "Electrical Equipment".

**5.8.2** Cables and devices for control of electric heating of pipelines, as well as pipelines located in dangerous spaces shall be of safe-type.

**5.8.3** The heating cable shall be installed after hydraulic tests of the pipelines and application of anticorrosive coating observing the manufacturer's technique approved by the Register.

**5.8.4** If necessary, pipelines equipped with electric heating shall be covered by a protective casing placed over the insulation to prevent mechanical damages of heating cables.

**5.8.5** When installing the heating cable, provision shall be made for loops at the locations of demountable joints of the pipeline to ensure dismounting of the pipeline without break of integrity of the heating cable.

**5.8.6** Warning notices "Caution, electric heating" shall be affixed to pipelines and valves with electric heating. The notices shall be located in conspicuous places at a 3 m distance along the pipeline length.

## 6 SHIP'S HOSES

### 6.1 CONSTRUCTION OF HOSES

**6.1.1** The requirements of the present Section cover ship's hoses for taking over and transfer of liquid cargo, fuel oil, lubricating oil, bilge and dirty ballast waters and transfer of cargo vapors.

**6.1.2** Only the hoses as finished items consisting of sleeves and end components (branch pipes with flanges, nipples or other joints) may be used in ships. The hoses shall have type approval of the Register, the manufacturer of sleeves shall be recognized by the Register.

**6.1.3** As a rule, a hose sleeve shall be made of rubber, reinforced with fabric, textile cord or cord from steel wire. In addition, the hose sleeve can be reinforced with one or several layers of wire coil, rings or by other means.

Sleeve material shall be resistant to the conveying medium within the whole range of temperatures, for this purpose special coating of the inner surface is allowed.

The outer surface shall be resistant to wear, attrition, exposure to sun rays, atmosphere and impermeable for sea water and cargo. The outer surface may be coated with polyurethane or other material, which affords buoyancy. Such coating shall display the similar properties in reference to external actions.

**6.1.4** End components shall be connected to the hose sleeve mechanically or chemically. Connection of sleeves with end components by means of clamps is permitted only by agreement with the Register.

**6.1.5** When welding is used in the structure of end components, such welding shall be performed by certified welders and is subject to 100 per cent check by non-destructive testing methods.

**6.1.6** The material of end components and flanges shall exclude the possibility of spark formation during interaction with ship's hull. Surfaces of end components shall be protected from corrosion influence of sea water and medium conveyed.

**6.1.7** The hose is assumed to be floating when its buoyancy reserve is at least 20 per cent, provided the hose is completely immersed in sea water and completely filled with it. The hose buoyancy reserve is calculated as follows:

$$K = \frac{B - (W_h + W_w)}{W_h + W_w} \times 100 \% \quad (6.1.7)$$

where  $K$  = buoyancy reserve, %;

$B$  = weight of sea water displaced by the hose at its complete immersion, including weight of sea water displaced by materials ensuring buoyancy and weight of sea water inside the hose, kg;

$W_w$  = weight of sea water inside the hose, kg;

$W_h$  = weight of empty hose in air, including weight of materials ensuring buoyancy, kg.

Materials applied for provision of buoyancy shall be properly secured.

**6.1.8** Floating hoses shall be orange-colored or marked with orange strip in the shape of spiral. The width of strip is 100 mm, the pitch of spiral is 450 mm. The strip is fixed to the facing in the process of curing.

**6.1.9** For the transfer of cargo at sea from one ship to another and during the cargo operations with the use of offset point berths, as a rule, the floating hoses shall be used; in the hose lines the quick-action device for emergency disconnection shall be provided.

In the hose lines equipped with quick-action device of emergency disconnection the allowance shall be made for hydraulic impact which may occur when the device is actuated and, if necessary, the flow velocity of liquid shall be decreased.

The hoses of the devices for cargo and bunkering operations shall be a matter of special consideration by the Register in each case.

**6.1.10** On both ends of a hose the following shall be clearly marked. In hose documentation the following shall be indicated:

name of the manufacturer or trade mark;

serial number of the hose according to the manufacturer's data;

month and year of production;

allowable working pressure;

indication of electrical conductivity.

**6.1.11** Hoses shall be stored on ship in the place shielded from direct sun rays, with allowance for the minimum bending radius and in accordance with the recommendations of the hose manufacturer. Provision shall be made for design means for discharge and removal of cargo remains from the hoses shall be provided. Measures for prevention of wearing through of the hoses while handling and operation shall be taken.

**6.1.12** For cargo vapor discharge, hoses with the allowable working pressure of at least 0,2 MPa and vacuum of at least 0,014 MPa shall be used. Burst pressure of the hose shall not be less than 5 times working pressure of the hose. The last meter from each end of the hose shall be painted in compliance with Fig. 6.1.12 and marked with the sign "vapors" made in black letters with the height not less than 50 mm. Each flange shall have an additional bore on the coupling bolts line for the stud of the shipboard manifold connecting flange (refer to 9.9.11 and Fig. 9.9.11-1). In the system for vapor to shore discharge only electrically conductive hoses shall be used.

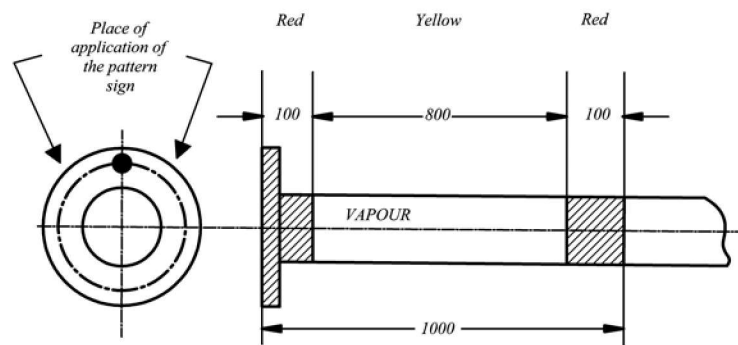

Fig. 6.1.12 Marking of cargo vapor discharge hose

## 6.2 TESTING OF HOSES

**6.2.1** Each sleeve type used for manufacture of hoses shall be subjected to type tests according to 6.2.2 to 6.2.5, 6.2.7, 6.2.8. Each hose type shall be type tested according to 6.2.2, 6.2.6, 6.2.7, 6.2.8. The type tests of hoses may be combined with the type tests of sleeves. After manufacture, each hose shall be tested in accordance with 6.2.6.

**6.2.2** Allowable working pressure  $P_w$  is determined as follows:

$$P_w = P_{burst}/K \quad (6.2.2)$$

where  $P_w$  = pressure, at which the break of hose or end connection tightness occurs;

$K$  = coefficient assumed equal to:

- 4 for transfer of crude oil and oily products, bilge and polluted ballast water;
- 5 for transfer of chemical cargoes, liquefied gases and cargo vapours.

Allowable working pressure of the hose shall not be less than 1,0 MPa, with exception of the hoses specified in 6.1.12.

When conducting the burst pressure tests, the testing of samples with the length not less than 10 nominal diameters but at least 1 m may be allowed.

**6.2.3** Sleeves for cargo and fuel oil hoses of ice-class ships shall be subjected to cold endurance type tests. For this purpose samples of the hoses shall be kept at the temperature of  $-40^\circ\text{C}$  during 4 h. In 4 h the sample shall be tested for elasticity by means of bending for  $180^\circ$  two times in the opposite directions around the adapter with a diameter of  $R$ , where  $R$  is a minimum bending radius; whereupon a visual examination is carried out. After freezing and bending no cracks shall appear on the internal and external surfaces of the sample. Where necessary, the sample may be cut along the axis for the internal surface inspection.

On agreement with the Register, another method for freeze resistance test with allowance made for special structural features may be accepted.

**6.2.4** The sleeves of hoses intended for operation under ambient pressure conditions shall be vacuum tested with negative pressure of 85 kPa during 10 min. After the tests the hose shall be examined and rejected where deformation or flattening is found.

**6.2.5** The samples manufactured as strip test pieces in accordance with the procedure approved by the Register (Fig. 6.2.5) are subject to adhesion test of all the rubber sleeve layers. The adhesion strength of rubber contact faces is determined as a ratio of the mean force  $F$  originated at detachment, divided by the strip width and shall be at least 3 N/mm.

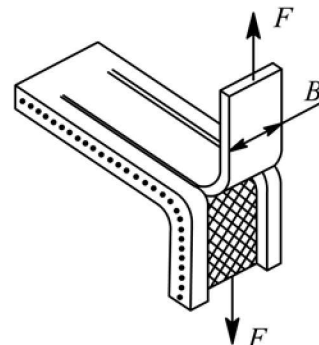

Fig. 6.2.5

**6.2.6** Each hose after manufacturing shall be subjected to the following tests:

**.1** determination of weight. After weighing, the hose weight shall be recorded in the certificate. For floating hoses, the buoyancy reserve shall be defined according to 6.1.7;

**.2** hydraulic tests by test pressure:  $P_t = 1,5P_w$ , where  $P_w$  – refer to 6.2.2;

**.3** electrotechnical tests including:

measuring of resistance between flanges of hoses lacking electrical conductivity (the resistance shall not be less than 25000 Ohm and not more than  $10^6$  Ohm);

conductivity test for electrically conductive hoses with the voltage of 4,5 V and a bulb for testing.

**6.2.7** The cargo hoses of oil tankers and hoses for taking on fuel and oil shall undergo type tests at normal

temperature for 15 cycles of pressure rise from zero up to 1,5 times the maximum allowable working pressure. After 15 cycles the sample shall be subjected to strength test by burst pressure according to 6.2.2.

**6.2.8** Cargo hoses for transfer of chemical cargoes and liquefied gases shall undergo type tests at normal

temperature for 200 cycles of pressure rise from zero up to twice the maximum allowable working pressure. After 200 cycles the sample shall be subjected to strength test by burst pressure according to 6.2.2.

## 7 BILGE SYSTEM

### 7.1 PUMPS

7.1.1 Each self-propelled ship shall be provided with at least two power bilge pumps.

Centrifugal bilge pumps shall be of self-priming type, otherwise the system shall be equipped with an air sucking-off arrangement. It is recommended that one of the installed pumps is of piston type.

Independent ballast, sanitary or general service pumps of sufficient capacity may be accepted as bilge pumps, and in ships of 91,5 m in length and less, including special purpose ships carrying not more than 60 persons, one of the bilge pumps may be a pump driven by the propulsion machinery, as well as a water or steam ejector, provided the steam boiler is always in operation.

If fire pumps are used as bilge pumps, the requirement of 3.2.3.3, Part VI "Fire Protection" shall be met.

In cargo ships of less than 500 gross tonnage of restricted areas of navigation **R2**, **R2-RSN**, **R2-RSN(4,5)**, **R3-RSN** and **R3**, one of the pumps may be driven by the propulsion machinery, and the other may be an ejector or a hand type.

7.1.2 Passenger ships and special purpose ships carrying more than 60 persons shall be fitted with at least three power pumps connected to the bilge main; one of these pumps may be driven by the propulsion machinery. Where the bilge pump numeral is 30 or more, one additional independent power pump shall be provided.

Independent ballast, sanitary and general service pumps of sufficient capacity may be accepted as bilge pumps.

Where in ships intended for the carriage of motor transport a water fire extinguishing system is used, the Register may require the bilge pumps to be increased in capacity or number.

7.1.3 The bilge pump numeral shall be calculated as follows:

when  $P_1$  is greater than  $P$ :

$$\text{bilge pump numeral} = 72 \left[ \frac{M + 2P_1}{V + P_1 - P} \right];$$

in other cases:

$$\text{bilge pump numeral} = 72 \left[ \frac{M + 2P}{V} \right]$$

where  $M$  — the volume of the machinery spaces below the bulkhead deck with the addition thereto of the volume of any permanent oil fuel bunkers which may be situated above the inner bottom and forward of, or abaft, the engine room,  $\text{m}^3$ . The volume of the machinery space shall include the volume between watertight boundaries of spaces containing the main

propulsion plant, auxiliary machinery, including boilers, generators and electric motors generally intended for providing the propulsion plant operation;

$P$  — the whole volume of the passenger and crew spaces below the bulkhead deck, which are provided for the accommodation and use of passengers and crew, excluding baggage, store, provision and mail rooms,  $\text{m}^3$ ;

$V$  — the whole volume of the ship below the bulkhead deck,  $\text{m}^3$ ;

$$P_1 = KN$$

where  $K = 0,056L$ ;

$L$  — the length of the ship as defined in the Load Line Rules for Sea-Going Ships, m;

$N$  — the number of passengers for which the ship shall be certified.

However, if the value of  $KN$  is greater than the sum of and the whole volume of the actual passenger spaces above the bulkhead deck, the figure to be taken as  $P_1$  is that sum or two-thirds  $KN$ , whichever is the greater.

7.1.4 On passenger and special purpose ships carrying more than 60 persons of 91,5 m in length and upwards or having a bilge pump numeral of 30 or more (refer to 7.1.3), the arrangements shall be such that at least one power bilge pump shall be available for use in all flooding conditions which the ship is required to withstand. This requirement is considered to be satisfied if one of the required bilge pumps is an emergency pump of a reliable submersible type having a source of power situated above the bulkhead deck; or the bilge pumps and their sources of power are so distributed throughout the length of the ship that at least one pump in an undamaged compartment will be available.

7.1.5 It is recommended that in passenger ships and special purpose ships not specified in 7.1.4 and in ships having a subdivision mark in the class notation the bilge pumps, wherever practicable, be placed in different watertight compartments with the system so arranged that requirements of 7.3.6 are met.

The bilge system of passenger ships having length, as defined in 1.2.1 of the Load Line Rules for Sea-Going Ships, of 120 m or more or having three or more main vertical zones shall comply with the requirements of 2.2.6.7.5, 2.2.6.8 and 2.2.7.4, Part VI "Fire Protection".

7.1.6 Each bilge pump required in 7.1.1 and 7.1.2 shall have a capacity  $Q$ , in  $\text{m}^3/\text{h}$ , not less than that determined from the formula

$$Q = 5,65 \times 10^{-3} \times d_1^2 \quad (7.1.6)$$

where  $d_1$  = inner diameter of the main determined in accordance with 7.2.1, mm.

The bilge pump may be replaced by two pumps with a total capacity not less than that specified above. For passenger ships, each bilge pump shall have a

capacity determined on the assumption that the rated speed of water through the internal diameter required in 7.2.1 shall not be less than 2 m/s.

**7.1.7** For drainage of non-propelled ships having no power-driven machinery, at least two hand pumps of reciprocating type shall be installed, and these shall have a total capacity not less than specified in Table 7.1.7.

Table 7.1.7

0,8 $LBD$ <sup>1)</sup> , m <sup>3</sup>	Total pump capacity, m <sup>3</sup> /h
Up to 100	$1,11 \cdot 10^{-3}$
101 — 600	$2,22 \cdot 10^{-3}$
601 — 1100	$2,72 \cdot 10^{-3}$
1101 — 1800	$3,34 \cdot 10^{-3}$

<sup>1)</sup>For definitions of  $L$ ,  $B$ ,  $D$  (length, breadth and depth, m), refer to Part IV "Stability".

In each case  $D$  is measured up to the bulkhead deck only.

In a ship having an enclosed cargo space on the bulkhead deck, which is drained in accordance with 7.6.12.2 and which extends for the full length of the ship,  $D$  shall be measured to the next deck above the bulkhead deck.

Where the enclosed cargo spaces cover a lesser length,  $D$  shall be taken as the depth to the bulkhead deck plus  $lh/L$  where  $l$  and  $h$  shall be length and height of enclosed cargo spaces, respectively.

The pumps shall be arranged above the bulkhead deck and shall have a sufficient suction head.

In non-propelled ships provided with power sources, it is recommended that power pumps shall be fitted, the number and capacity of which shall comply with the requirements for the hand pumps.

**7.1.8** In ships with twin hulls, provision shall be made for an independent bilge system for each hull, which shall comply with the requirements of the Chapter.

**7.1.9** In berth-connected ships, at least two bilge pumps shall be installed, power-driven and having each a capacity not less than 11,0 m<sup>3</sup>/h whereas the design water speed in the branch bilge suction shall not be less than 2 m/s under normal service conditions.

In case where a berth-connected ship serves its direct service without shore power supply and the ship is not provided with a propulsion plant, the power-driven bilge pumps may be omitted, and the bilge system shall meet the requirements of 7.1.7.

The pumps shall ensure drainage of any space below the bulkhead deck, and their drives shall be so arranged along the ship length that at least one of the pumps installed in an intact compartment could drain a flooded space.

**7.1.10** Ships with distinguishing marks **FF1**, **FF1WS**, **FF2**, **FF2WS** in the class notation shall have

bilge pumping arrangements for pumping water out of flooded compartments of ships in distress.

Used as such arrangements may be pumps (fixed and/or portable) and ejectors.

The type, number and capacity of the pumps shall be specified by the designer and agreed upon with the Register.

**7.1.11** Instruments shall be provided to measure suction pressure and delivery pressure of each bilge pump.

## 7.2 PIPING DIAMETERS

**7.2.1** The internal diameter  $d_1$ , in mm, of the main bilge line and that of bilge suction directly connected to the pump, except in 7.2.3, shall be determined by the formula

$$d_1 = 1,68 \sqrt{L(B+D)} + 25. \quad (7.2.1-1)$$

In vessels of dredging fleet having hopper spaces, the diameter of the bilge main and the direct bilge suction directly connected to the pump may be obtained from the formula

$$d_1 = 1,68 \sqrt{L(B+D) - l_1(b+D)} + 25 \quad (7.2.1-2)$$

where  $l_1$  = length of hopper space, m;  
 $b$  = mean width of hopper space, m;  
 for  $L$ ,  $B$ ,  $D$ , refer to 7.1.7.

In cargo ships of less than 500 gross tonnage navigating in restricted areas **R2**, **R2-RSN**, **R2-RSN(4,5)**, **R3-RSN** and **R3** the internal diameter of the bilge main and of direct bilge suction directly connected to the pump may be obtained from the formula

$$d_1 = 1,5 \sqrt{L(B+D)} + 25. \quad (7.2.1-3)$$

**7.2.2** The internal diameter  $d_1$ , in mm, of the branch bilge suction connected to the bilge main, and that of the hand pump suction, shall be determined by the formula

$$d_1 = 2,15 \sqrt{l(B+D)} + 25 \quad (7.2.2-1)$$

where  $l$  = length of hopper space, as measured at its bottom, m;  
 for  $B$ ,  $D$ , refer to 7.1.7. In the case of ships with twin hulls,  $B$  is assumed to be the breadth of one hull.

In cargo ships of less than 500 gross tonnage navigating in restricted areas **R2**, **R2-RSN**, **R2-RSN(4,5)**, **R3-RSN** and **R3** the internal diameter of branch bilge suction connected to the bilge main and the diameter of the hand pump suction may be obtained from the formula

$$d_1 = 2,0 \sqrt{l(B+D)} + 25. \quad (7.2.2-2)$$

**7.2.3** The internal diameter of the main bilge line and bilge suction determined from Formulae (7.2.1-1,

7.2.2-1) shall not be less than 50 mm, and the internal diameter determined from Formulae (7.2.1-3, 7.2.2-2) shall not be less than 40 mm. The internal diameter of the pipes directly connected to the pump shall not, in any case, be less than the bilge pump suction diameter.

**7.2.4** The cross-sectional area of the pipe, connecting the distribution chest with the bilge main shall not be less than the total cross-sectional area of two largest branch bilge suction connected to that chest, but it need not be greater than the sectional area of the bilge main.

**7.2.5** In oil tankers and other ships, in which the bilge pumps are intended for draining only the engine room, the cross-sectional area of the bilge main shall not be less than twice the cross-sectional area of the branch suction, the diameter of which is determined by Formula (7.2.2-1).

**7.2.6** The diameter of the emergency bilge suction in the engine room shall be determined in compliance with 7.4.6.

### 7.3 PIPING LAYING

**7.3.1** The bilge lines and their branch suction shall be so arranged as to enable any watertight compartment to be drained by one of the pumps required in 7.1.1 and 7.1.2. This requirement does not apply to the spaces of ammonia refrigerating machinery, the peaks, the pump rooms and cofferdams of oil tankers, drained by individual pumps, as well as to the tanks intended only for storage of liquids.

Drainage of spaces not connected to the bilge system shall be carried out by the drain pipes laid to the drained spaces or by hand pumps, compliance with the requirements of 7.12.2 shall also be provided.

**7.3.2** The system shall be arranged so as to prevent the possibility of sea water passing inside the ship, or from one watertight compartment into another, in case of pipe break or any other pipe damage in any other compartment because of collision or grounding. For this purpose the suction valves of the drainage pipes open ends, connected directly to the chests, shall be of screw-down non-return type. In case the only general pipeline system for all pumps is available, the provision shall be made for the possibility to control the required valves servicing suction branch pipes from the places above the bulkhead deck. Other equivalent arrangements are allowed.

**7.3.3** The arrangement of the bilge pipes shall be such as to ensure the possibility of draining the engine rooms through the suction directly connected to the pump, the other compartments being simultaneously drained by other pumps.

**7.3.4** The arrangement of the bilge pipes shall be such as to enable one of the pumps to be operated in

case the rest of pumps are inoperative or are used for other purposes.

**7.3.5** The bilge suction pipes, where they are at any part situated nearer to the ship's side than one-fifth of the breadth of the ship (measured at right angles to the centre line at the level of the deepest subdivision load line), as well as when passing in duct keel or within double bottom, shall have non-return valves fitted to their branch suction in each watertight compartment.

**7.3.6** On passenger ships of more than 91,5 m in length, special purpose ships carrying more than 60 persons and in passenger ships having a bilge pump numeral of 30 or more, all the distribution chests, cocks and valves associated with the bilge pumping system shall be so arranged that in the event of flooding one of the bilge pumps may be operative on any flooded compartment. Moreover, damage of a pump or its pipe connecting to the bilge main outboard of a line drawn at one-fifth of the breadth of the ship shall not put the bilge system out of action.

Where there is only one system of pipes common to all the pumps, the necessary cocks and valves for controlling the bilge suction shall be fitted with means enabling them to be controlled from above the bulkhead deck.

In the places of their installation they shall be provided with the controls with clear indication of their purpose and also means for indicating whether they are open or closed.

Where, in addition to the main bilge pumping system, an emergency bilge pumping system is provided, it shall be independent of the main system and shall be so arranged that a pump is capable of operating on any compartment under flooding conditions. In this case, only the cocks and valves required for controlling the emergency system need be suited for being operated from above the bulkhead deck, while the pump and associated suction pipes shall be situated farther from the ship's side than one-fifth of the breadth of the ship.

**7.3.7** In general, the bilge pipes shall be laid outside the double bottom. Where it is necessary to lay these pipes through the tanks for storage of fuel oil, lubricating oil, boiler feed water and drinking water, the pipes shall meet the requirements of 5.2.1.

Where the pipe is laid within the double bottom, the bilge suction in each watertight compartment shall be fitted with non-return valves.

**7.3.8** Oily-water separating and filtering equipment shall be used for purification of water before discharging overboard. The installation and operation of such equipment shall not interfere with normal working of the bilge and ballast systems indicated in 13.1.2.

#### 7.4 DRAINAGE OF MACHINERY SPACES

**7.4.1** Where the engines and boilers are located in the same compartment and the double bottom extends either the full length forming bilges at the wings, or the full length and breadth of the compartment, it will be necessary to provide two bilge suction at each side near the bulkheads in the compartment, one of which shall be connected directly to an independent bilge pump.

**7.4.2** Where the engines and boilers are located in the same compartment with no double bottom, and the rise of floors is not less than 5°, two bilge suction shall be provided, one of which shall be direct-connected to an independent bilge pump; where the rise of floor is less than 5°, additional bilge suction connected to the bilge main shall be provided, one at each side.

**7.4.3** Where the engines and boilers, as well as the auxiliaries or electric propulsion motors, are located in separate watertight compartments, the number and position of bilge suction therein shall be adopted as set forth in 7.6. In ships having in the class notation a mark of subdivision, each of these compartments shall be fitted with an additional bilge suction direct-connected to an independent bilge pump.

In passenger ships each of the independent power bilge pumps, located in machinery spaces, shall have direct suction in these spaces. More than two such suction are not required for these spaces. Where two or more such suction are fitted, at least one of them shall be located on the port and the other on the starboard side. Bilge pumps not associated with each other, located in other spaces may have direct suction in these spaces.

**7.4.4** Where the machinery space is situated at the after end of the ship, bilge suction shall be fitted in the forward wings of the space. On agreement with the Register, one or two suction shall be provided depending on the shape of the aft end.

**7.4.5** Suction for bilge drainage of machinery spaces and tunnels shall be fitted with readily accessible mud boxes. The pipes between the mud boxes and bilges shall be as straight as practicable. The lower ends of these pipes need not be fitted with strum boxes. Mud boxes shall have covers that may be easily opened.

In small ships, instead of the mud boxes, strum boxes may be used, provided they are accessible for cleaning.

**7.4.6** In all self-propelled ships provision shall be made for emergency bilge drainage of the engine rooms, in addition to the suction required by 7.4.1 to 7.4.4. For this purpose any of the main circulating pumps in steam ships, and the cooling pump of maximum capacity in motor ships, shall be fitted with

direct suction pipe at the drainage level of the engine room and fitted with non-return stop valve. The diameter of this direct suction shall be at least two-thirds of that of the pump suction in steam ships, and shall be of the same size as the suction branch of the pump in motor ships.

No strum boxes or strainers shall be fitted on the suction for emergency bilge drainage.

Where the pumps specified above are not suitable for operation as bilge pumps, a direct emergency bilge suction shall be laid from the drainage level of the engine room to the largest available power pump, which is not a bilge pump. The capacity of this pump shall exceed that required in 7.1.6 by an amount satisfactory to the Register. The diameter of the emergency bilge suction shall not be less than that of the pump suction branch.

The spindles of the screw-down non-return valves fitted to the suction branches shall extend above the engine room floor plates to a sufficient height and shall have nameplate "For emergency use only".

The use of fire pumps for emergency bilge drainage of engine rooms shall be in compliance with 3.2.3.2, Part VI "Fire Protection".

In cargo ships of less than 500 gross tonnage navigating in restricted areas **R2**, **R2-RSN**, **R2-RSN (4,5)**, **R3-RSN** and **R3** which have no independent pump of a capacity exceeding that of the bilge pump, the emergency drainage system of machinery spaces may be operated by an attached sea-water cooling pump.

**7.4.7** Where there is a double bottom, the machinery spaces shall be fitted with bilge wells of a capacity not less than 0,2 m<sup>3</sup>.

**7.4.8** Additional bilge suction shall be laid in the log and echo sounder trunks, and also to the double-bottom bilge wells under the machinery and in other places, which may accumulate water.

**7.4.9** In ships having an electric propulsion plant, the arrangements shall be such that the bilge wells under the propulsion motors are properly drained and automatic alarms are fitted to give warning at excess of permissible level in the wells.

Automatic drainage of bilge wells is recommended to be used.

**7.4.10** The space of ammonia refrigerating machinery shall have an independent bilge system. Where a water spraying system is provided in this space, the capacity of the bilge pump shall be sufficient for the water consumption during the operation of that system. The discharge pipe of the bilge system shall be laid directly overboard.

The space for freon refrigerating machinery may be drained through the bilge main of the ship.

## 7.5 DRAINAGE OF TUNNELS

**7.5.1** Each shaft tunnel and each accessible pipe tunnel shall be drained by a bilge suction situated in the after part of the tunnel.

Where required, additional suction shall be provided in the fore part of the tunnel. The bilge suction of the shaft tunnel shall be made in compliance with the requirements set forth in 7.4.5.

## 7.6 DRAINAGE OF CARGO SPACES

**7.6.1** Each cargo space, where the double bottom forms bilges at the wings, shall have at least one bilge suction in the after part of the hold at each side of the ship.

**7.6.2** Where the inner bottom plating extends the full breadth of the space, bilge wells shall be arranged in the after part of the hold, one at each side.

The capacity of the wells shall comply with the requirements of 7.4.7.

**7.6.3** In spaces where the inner bottom plating has an inverse camber, provision shall be made also for suction at the centre line, in addition to the suction situated at the wings. Where a bilge well extends over the entire breadth of the space and the inverse camber exceeds 5°, one branch suction may be laid to this well.

**7.6.4** Where manholes for access to bilge wells are provided, they shall be arranged as near to the suction strums as practicable.

**7.6.5** Where there is no double bottom and the rise of floor in the space exceeds 5°, one bilge suction may be fitted near the centre line. If the rise of floor is less than 5°, at least two suction shall be fitted, one at each side of the hold.

**7.6.6** Where the length of a hold exceeds 35 m, the bilge suction shall be fitted in the fore and after parts of this hold, with the requirements of 7.6.1 to 7.6.5 being complied with.

**7.6.7** At narrow ends of cargo spaces, one bilge suction may be allowed.

**7.6.8** The drain pipes from spaces located below the bulkhead deck and communicating with the cargo space in the same compartment may be laid into the wells of that hold.

Drainage into the wells of cargo spaces from spaces located in other watertight compartments below the bulkhead deck is not permitted.

The requirements for drainage into the bilges of refrigerated cargo spaces are given in 7.8.

**7.6.9** Where a ceiling or removable covers is fitted over the bilges or wells in cargo spaces, provision shall be made for free access of water into the bilges or wells.

**7.6.10** Branch bilge suction shall be fitted with strum boxes or strainers having perforations 8 to 10 mm in size. The total area of these perforations shall not be less than twice the clear area of the given suction pipe.

The strum boxes and strainers shall be removable, or provision shall be made for cleaning them without having to disassemble the suction.

**7.6.11** In bulk carrier cargo spaces the bilge system shall be so designed that its operability may not be affected when bulk cargo is carried.

**7.6.12** For the drainage of enclosed cargo spaces located on the bulkhead deck of a passenger or cargo ship that is assigned a subdivision distinguishing mark in its class notation, and on the freeboard deck of other cargo ships, the arrangements specified under 7.6.12.1 and 7.6.12.2 shall be provided.

**7.6.12.1** Where the freeboard up to the bulkhead deck or the freeboard deck height is such that the deck edge is immersed when the ship heels more than 5°, the drainage shall be by means of scuppers discharging directly overboard.

The scuppers and drain pipes shall be arranged and fitted according to 4.3.2.6 or 7.12.4.

**7.6.12.2** Where the freeboard is such that the edge of the deck is immersed when the ship heels 5° or less, the drainage of the enclosed cargo spaces on this deck shall be laid to suitable spaces of adequate capacity having a high water level alarm and suitable arrangements for discharge overboard. In such cases it shall be ensured that:

.1 the number, size and disposition of the scuppers are such as to prevent unreasonable accumulation of free water;

.2 the pumping arrangements for the drainage of cargo spaces provide water drainage with any fixed water fire extinguishing systems, including spraying systems, that are required, respectively, for passenger and cargo ships.

The bilge system (refer to 7.1) shall have a capacity not less than 125 per cent of the total capacity of the water fire main and water-spraying system pumps with due regard for the required number of fire nozzles and be calculated considering the requirements of IMO MSC.1/Circ.1320;

.3 valves of the drainage arrangements shall be controlled from a position outside the space protected, located nearby the water-spraying system controls. Bilge wells shall have sufficient capacity and be arranged in the vicinity of the side plating not more than 40 m apart in each watertight compartment. Water contaminated with petrol or other dangerous substances shall not be drained to machinery spaces or other spaces containing sources of ignition;

.4 where the enclosed cargo space is protected by a fire smothering system the deck scuppers are fitted with means to prevent the escape of the gas.

**7.6.12.3** On all ships, for closed vehicles and ro-ro spaces and special category spaces, where fixed pressure water-spraying systems are fitted, means shall be provided to prevent the blockage of drainage arrangements, taking into account the requirements of IMO MSC.1/Circ.1320.

An easily removable grating, screen or other means shall be installed over each drain opening in the protected spaces to prevent debris from blocking the drain. The total open area ratio of the grating to the attached drain pipe shall be at least 6 to 1. The grating shall be raised above the deck or installed at an angle to prevent large objects from blocking the drain. No dimension of the individual openings in the grating shall be more than 25 mm. A clearly visible sign or marking shall be provided not less than 1500 mm above each drain opening stating: "Drain opening — do not cover or obstruct". The marking shall be in letters at least 50 mm in height.

**7.6.13** The bilge system of cargo holds with weathertight hatch covers above the superstructure deck outside the positions 1 and 2 (refer to 7.1.4, Part III "Equipment, Arrangements and Outfit" of the present Rules and 3.2.1 of the Load Line Rules for Sea-Going Ships) shall have the pumps of an increased capacity with regard to additional water ingress due to:

.1 the stable amount of precipitation equal to 100 mm/h, which penetrate through the total area of gaps between closures sections;

.2 the consumption of water by a sprinkler system (if fitted), whichever is greater.

The internal diameter of a bilge main shall be increased in compliance with an increased pump capacity.

Each cargo hold shall be fitted with an alarm on a limiting water level in bilge wells.

**7.6.14** On container ships, holds fitted with weathertight closures and intended for carriage of dangerous cargoes shall be considered as open-type container holds in accordance with paragraphs 10 and 11 of MSC/Circ.608/Rev.1.

**7.6.15** The cargo spaces of bulk carriers and single-hold cargo ships shall be provided with alarms complying with the requirements of 2.4, Part XV "Automation", located on the navigating bridge, as well as 7.10, Part XI "Electrical Equipment".

The alarm system detectors shall be positioned at two levels:

at a height of 0,5 m above the inner bottom;

at a height of 15 per cent of the depth of cargo space but not more than 2 m above the inner bottom.

The visual signals of each cargo space and each level shall be clearly distinguishable.

For cargo holds, which are used for water ballast, an alarm-overriding device may be installed to be activated when ballast is loaded thereinto.

#### **7.7 DRAINAGE OF CARGO PUMP SPACES OF OIL TANKERS**

**7.7.1** The cargo pump rooms of oil tankers shall be drained by separate pumps or ejectors arranged in these rooms. Stripping pumps may be used as bilge pumps, provided non-return shut-off valves are fitted at the open ends of the bilge suctions and a shut-off valve is arranged on a pipe connecting the valve box and the stripping pump.

The pump rooms in oil tankers of up to 500 gross tonnage may be drained by hand pumps.

Construction of the pumps shall preclude the possibility of spark formation to a maximum.

Arrangement of the driving machinery of the pumps shall meet the requirements of 4.2.5, Part VII "Machinery Installations".

The cargo pump rooms shall be provided with a visual and audible high bilge water level alarm to give warning to the cargo control station and navigation bridge.

#### **7.8 DRAINAGE OF REFRIGERATED CARGO SPACES**

**7.8.1** Provision shall be made for drainage of water from all the spaces, trays, chutes and other places, which may accumulate water.

**7.8.2** Drain pipes from non-refrigerated spaces shall not be laid into the bilges of refrigerated spaces.

**7.8.3** Each drain pipe of refrigerated cargo spaces shall be fitted with a liquid sealed trap or with another equivalent arrangement. The head of liquid shall be such that the arrangement will work effectively under any conditions of service.

The liquid sealed traps shall be placed in accessible positions outside the insulation. Where drain pipes from the 'tween-deck spaces and the hold are laid into a common bilge well, non-return valves shall be fitted to the open ends of the drains from the hold.

**7.8.4** No shut-off valves shall be fitted on the drains from refrigerated spaces.

### 7.9 DRAINAGE OF FORWARD SPACES OF BULK CARRIERS

**7.9.1** The present requirements apply to the means for draining and pumping ballast tanks forward of the collision bulkhead, and bilges of dry spaces, any part of which extends forward of the foremost cargo hold, except the enclosed spaces the volume of which does not exceed 0,1 per cent of the ship maximum displacement volume and the chain lockers.

**7.9.2** The means for draining and pumping ballast tanks forward of the collision bulkhead, and bilges of dry spaces, any part of which extends forward of the cargo hold, shall be capable of being brought in operation from the navigation bridge or propulsion machinery control position or from a readily accessible enclosed space, the location of which is accessible from the navigation bridge or propulsion machinery control position without traversing exposed freeboard or superstructure decks. A pipe trunk or other similar means of access shall not be taken as being a "readily accessible enclosed space".

**7.9.3** The drainage arrangements shall be such that when they are in operation, other systems essential for the safety of the ship including fire-fighting and bilge systems remain available and ready for immediate use.

The systems for normal operation of electric power supplies, propulsion and steering shall not be affected by the operation of bilge systems.

It shall be also possible to immediately start fire pumps and have a readily available supply of water and to be able to configure and use bilge system for any compartment.

**7.9.4** The drainage arrangements shall be such that any accumulated water can be drained directly by a pump or eductor. The drainage arrangements shall be designed to remove water at a rate of not less than  $320 \cdot A$ , m<sup>3</sup>/h, where A is the cross-sectional area in m<sup>2</sup> of the largest air or venting pipe leading from the exposed deck to the space that is required to be drained.

**7.9.5** Bilge wells shall be provided with gratings or strainers that will prevent blockage of the bilge system with debris.

**7.9.6** Where pipes serving tanks or bilges mentioned in 7.9.2 pierce the collision bulkhead, as an alternative to the valve control specified in 5.1.3, valve operation by means of remotely operated actuators may be accepted, provided that the location of such valve controls complies with 7.9.2.

**7.9.7** Where the piping of closed spaces bilge system is connected to the piping arrangements for the drainage of water ballast tanks, two non-return valves shall be provided to prevent the ingress of

water into dry spaces from the water ballast tanks. One of these non-return valves shall be fitted with shut-off isolation arrangement. The non-return valves shall be located in readily accessible positions. The valve control position shall meet the requirements of 7.9.2.

Moreover, the valve shall comply with the requirements of 4.1.1.2 and 4.1.2.2.

**7.9.8** Any dry spaces or cofferdams other than chain lockers, the volume of which does not exceed 0,1 per cent of the ship maximum displacement volume, fully or partly located forward of the foremost cargo hold, shall be fitted with water level detectors giving audible and visual alarms at a water level of 0,1 m above the deck.

**7.9.9** The water ballast tanks forward of the collision bulkhead shall be provided with detectors giving an audible and visual alarms when the liquid in the tank reaches a level not exceeding 10 per cent of the tank capacity. An alarm overriding device may be installed to be activated when the tank is in use.

### 7.10 DRAINAGE OF COFFERDAMS

**7.10.1** Cofferdams filled with water shall be provided with drainage means. The location of branch suction shall comply with the requirements of 7.6. In oil tankers and combination carriers, the filled cofferdams adjoining cargo tanks or slop tanks shall have automatic drain arrangements.

### 7.11 FORE AND AFT PEAK DRAINAGE

**7.11.1** Where the peaks are not used as water ballast or other tanks, they may be drained by their own hand pumps or water ejectors.

For draining of fore compartments in oil tankers, other than cargo compartments, provision shall be made for a separate pump or ejector, which may also be used for filling and draining of the tanks intended only for water ballast.

### 7.12 DRAINAGE OF OTHER SPACES

**7.12.1** Drainage of the chain lockers and boatswain's stores may be carried out by means of hand pumps, water ejectors or other means.

**7.12.2** Drainage of the steering engine rooms and other compartments situated above the after peak may be carried out by hand pumps or water ejectors, as well as through drain pipes laid into the bilges of shaft tunnel or engine room. The drain pipes shall be

fitted with readily accessible self-closing valves and shall be of not less than 39 mm in inner diameter.

In passenger ships, drain pipes shall not be used for drainage of the above-mentioned spaces.

**7.12.3** Drain pipes shall not be laid into the bilges of the engine rooms and shaft tunnels from the spaces situated in other watertight compartments below the bulkhead decks (with the exception of cases specified by 7.12.2).

Drain pipes from these spaces may be laid into the engine rooms and shaft tunnels only if terminating in closed drain tanks.

Where several watertight compartments have a common drain tank, the drain pipes from these compartments shall be fitted with non-return valves to prevent the passage of water from one compartment into another in the event of flooding.

The drain tank may be discharged through the bilge main, provided a non-return valve is fitted on the branch suction or the distribution chest.

**7.12.4** Drain pipes from enclosed superstructures and deckhouses may be laid into the bilges (wells) of the engine room or the holds.

In ships having in the class notation a mark of subdivision, these pipes shall be fitted with valves controllable from a place above the bulkhead deck to prevent penetration of water in the above-mentioned spaces shall the engine room or hold become flooded.

**7.12.5** Drain pipes for drainage of storerooms for explosives shall be fitted with valves controllable from locations outside these rooms.

**7.12.6** Drainage facilities in way of helidecks shall be constructed of steel and shall lead directly overboard independent of any other system. Drainage shall not fall onto any part of the ship.

#### **7.13 DRAINAGE OF FLOATING DOCK COMPARTMENTS**

**7.13.1** Machinery spaces and dry compartments shall be provided with draining means. The requirements of this Section, except 7.3.2 and 7.3.8, are not applicable to the drainage system of floating docks.

#### **7.14 DRAINAGE OF SPACES INTENDED FOR THE CARRIAGE OF DANGEROUS GOODS**

**7.14.1** Enclosed cargo spaces and cargo spaces of container ships of open type intended for the carriage of flammable liquids with flash point below 23 °C or toxic liquids of subclass 6.1 specified in 2.8.2 and Table 2.8.2-3, Part VI "Fire Protection" shall be equipped with the fixed drainage system located outside the machinery space. The self-contained drainage system shall meet the following requirements:

**.1** the capacity of the self-contained drainage system shall be not less than 10 m<sup>3</sup>/h when one space is drained and not less than 25 m<sup>3</sup>/h when two or more spaces are drained;

**.2** the use of pipelines of the ship's main drainage system located in these spaces is allowed, if measures are taken to prevent pumping of flammable or toxic liquids through the pipelines and pumps of the engine room through installation of a blank flange or a shut-off valve;

**.3** cargo spaces may be drained by gravity overboard or into a closed drainage tank located outside the engine room. The tank shall have an air pipe led to the safe position on the open deck and be protected by flame screen;

**.4** cargo spaces may be drained into bilge wells located below spaces intended for the carriage of dangerous goods;

**.5** enclosed spaces with pumps of the self-contained drainage system shall be provided with ventilation arrangements complying with the requirements of 12.7.1.

**7.14.2** The drainage and pumping arrangements servicing spaces intended for the carriage of explosives shall prevent the build-up of free water surfaces when fire-extinguishing systems are used.

The capacity of the drainage system shall be 1,25 times greater the combined capacity of both water spraying system pumps and fire hose nozzles specified in 3.2, Part VI "Fire Protection".

The drainage system valves shall be operable from outside the protected space at a position in the vicinity of the extinguishing system controls.

## 8 BALLAST, HEEL AND TRIM SYSTEMS

### 8.1 PUMPS

**8.1.1** The ballast system shall be served by at least one pump. The capacity of the ballast pump shall be such as to ensure the speed of water of not less than 2 m/s, with the suction pipe diameter taken from Formula (8.2.1) as for the largest ballast tank.

For each hull of a ship with twin hulls, an independent ballast system shall be provided.

**8.1.2** General service pumps of sufficient capacity, as well as a bilge, fire or standby cooling pump, may be used for ballasting (refer to 8.1.3).

Fire pumps may be permitted subject to compliance with 3.2.3.2 and 3.2.3.4, Part VI "Fire Protection".

**8.1.3** Where the fuel oil tanks are generally used as ballast tanks, the standby cooling pump or a fire pump shall not be used for ballasting, nor shall the ballast pump be used as fire pump or standby cooling pump.

**8.1.4** The pumps used for pumping out ballast water from the double-bottom tanks shall be of self-priming type and comply with 5.2.4, Part IX "Machinery".

**8.1.5** In passenger ships, ballast tanks shall not, generally, be intended for the carriage of fuel oil.

**8.1.6** In oil tankers emergency ballast discharge by stripper and cargo pumps is allowed, provided the requirements of 9.10.2 are complied with.

**8.1.7** The ballast system of passenger ships having length, as defined in 1.2.1 of the Load Line Rules for Sea-Going Ships, of 120 m or more or having three or more main vertical zones shall comply with the requirements of 2.2.6.7.5 and 2.2.6.8, Part VI "Fire Protection".

### 8.2 PIPING DIAMETERS

**8.2.1** The internal diameter  $d_i$ , in mm, of the ballast pipes for separate tanks shall be determined by the formula

$$d_i = 18^3 \sqrt{v} \quad (8.2.1)$$

where  $v$  = ballast tank capacity, m<sup>3</sup>.

The diameter may be adopted by the nearest standard size.

**8.2.2** The diameter of the ballast main shall not be less than the maximum diameter of the suction determined by Formula (8.2.1).

### 8.3 PIPING LAYING

**8.3.1** The arrangement of the suctions shall be such as to ensure pumping of the water from any of the ballast tanks, whether the ship is on even keel or listed 5°.

**8.3.2** In icebreakers and Arc4 to Arc9 ice class ships, the fore and after peaks, as well as structural wing tanks for water ballast, located above the waterline and in way of cargo holds, shall be provided with heating arrangements. The double-bottom tanks in way of cargo holds, intended for water ballast, are recommended to be fitted with heating coils.

**8.3.3** The suction and discharge pipes of segregated ballast tanks shall not communicate with sea chests and pipelines servicing cargo tanks.

### 8.4 BALLAST SYSTEM OF FLOATING DOCKS

**8.4.1** The ballast system shall be so designed that at least two pumps are available at any ballast compartment.

**8.4.2** In floating docks intended for service under negative temperatures, the pumps and valves shall be located in warmed spaces of the dock or shall be provided with local heating.

**8.4.3** If the valves of the ballast system are controlled from a power source, then the sea inlet and discharge valves at side shall have manual emergency driving means laid to above the safety deck. In this case, the distributing valves are recommended to be fitted with a device automatically closing them, shall supply from the power source by interrupted.

### 8.5 HEEL AND TRIM SYSTEMS

**8.5.1** The heel and trim systems shall be in compliance with 8.3.2 and 8.3.3.

**8.5.2** A valve or shutter shall be fitted on the cross-flow line in the heeling system and stabilization system which is automatically locked in case of loss of power supply.

### 8.6 BALLAST SYSTEM OF BULK CARRIERS

**8.6.1** Each water ballast tank forward of the collision bulkhead shall be provided with a water level detector giving audible and visual alarms when the liquid in the tank reaches a level not exceeding 10 per cent of the tank capacity.

**8.6.2** On bulk carriers, the means for draining and pumping ballast tanks forward of the collision bulkhead shall comply with 7.9.

#### **8.7 BALLAST SYSTEMS FOR BALLAST WATER EXCHANGE AT SEA**

The requirements of this Chapter are mandatory for ships having the Ballast Water Management Plan.

**8.7.1** Permissible methods of ballast water exchange at sea:

refill method is a process, by which a ballast tank or hold is first emptied of at least 95 per cent of its volume and then refilled with replacement ballast water;

flow-through method is a process, by which replacement ballast water is pumped through the ballast tank or hold allowing the water to overflow or flow through other arrangements. At least 3 times the tank or hold volume shall be pumped through the tank or hold;

dilution method is a process, by which replacement ballast water is filled in the ballast tank or hold through the tank top with simultaneous discharge of the same water quantity and maintaining a constant level in the tank or hold. At least 3 times the tank or hold volume shall be pumped through the tank or hold.

**8.7.2** Ballast water system shall provide pumping in and out any ballast tank and hold under any environmental conditions permitted by the Ballast Water Management Plan.

**8.7.3** Where the flow-through method of water ballast exchange is used, overpressure in the tank or hold more than designed pressure shall be avoided.

**8.7.4** Every ballast tank or hold shall be provided with shut-off valves for pumping in and/or out.

**8.7.5** To ensure that the movement of ballast water only takes place as required, shut-off valves for the ballast tanks or holds shall be permanently closed, except the water ballast handling. In general, the shut-off valves shall be of self-closing spring type or equivalent.

**8.7.6** The relative positions of ballast water intake and discharge openings shall be such as to preclude as far as practicable the possibility of contamination of replacement ballast water by water being pumped out.

**8.7.7** The ballast system intended for ballast water exchange shall be served by at least two pumps. Where the ship's Ballast Water Management Plan permits the use of the refill method, each pump shall be capable of providing ballast water exchange of the largest ballast water tank or group of tanks as per the ship's Ballast Water Management Plan within 3 h.

**8.7.8** Ballast water exchange of cargo holds used for the carriage of water ballast may require an extended period of time but not more than 24 h by one pump.

**8.7.9** The ballast system design shall permit the ballast water exchange operations with the minimum number of operational modes.

**8.7.10** The internal arrangements of ballast tanks as well as ballast water piping inlet and outlet arrangements shall permit the complete ballast water exchange and the cleaning of any sediments.

**8.7.11** Design of sea suction line strainers shall be such as to permit cleaning of strainers without interrupting of water ballast handling.

**8.7.12** Ballast pumps and all valves to be operated during ballast water exchange shall be provided with a means of remote control from a central ballast control station. Furthermore, the ballast pumps shall be provided with a means of local control.

**8.7.13** A manually operated independent means of control of all valves required for ballast water exchange shall also be provided for emergency operation in the event of main centralized remote control failure. Where the valves are located inside tanks or other hardly accessible spaces, the manually operated independent means of control may be achieved by connections to the control lines of individual valves.

**8.7.14** The central ballast control station shall include the following:

- a valve position indicating system;
- a current tank level indicating system;
- a draught indicating system;
- a means of communication between the central ballast control station and those spaces containing the means of local control for the ballast pumps and the manually operated independent means of control.

**8.7.15** The centralized remote control system shall be arranged so that the failure of any one of the control system components will not cause the loss of operation to the pumps or valves or other systems.

**8.7.16** Design of ballast tanks shall permit, when necessary, taking samples of the ballast water and sediments. Fitting of tank hatch in addition to conventional manhole is recommended for this purpose. Spaces straight below any tank opening shall be kept free of obstructions that could impede taking samples or free access.

**8.7.17** The capability of the ballast water system to provide ballast water exchange by the flow-through method without the risk of overpressure in the ballast tanks shall be demonstrated by calculations and testing on board.

**8.7.18** The flow-through method with water flowing over the upper deck is not permitted. The use of collecting pipes, internal overflow pipes or

interconnecting pipe/trunk arrangements between tanks may be allowed to avoid water flowing over the upper deck.

**8.7.19** Where dilution method is used, the following arrangements shall be provided:

special arrangements automatically maintaining the constant ballast water level. These arrangements shall provide for a manual emergency stop of the

ballast pump in case of valve failure or incorrect control actions.

high and low water level alarms in tanks where the ballast water level will significantly change affecting the safety of the ship during water ballast handling.

## 9 SYSTEMS SPECIAL FOR CARRIAGE OF CARGOES IN BULK

### 9.1 APPLICATION

9.1.1 The requirements of the Section apply to ships intended for carriage of liquid cargoes in bulk and having the descriptive notation "Oil tanker" and "Oil/bulk/ore carrier", "Oil recovery ship", "Oil/bulk carrier", "Oil/ore carrier".

9.1.2 For the ships with the descriptive notation "Oil tanker (> 60 °C)", "Oil/bulk/ore carrier (> 60 °C)", "Oil recovery ship (> 60 °C)", "Oil/bulk carrier (> 60 °C)", "Oil/ore carrier (> 60 °C)" and "Bilge water removing ship", compliance with 9.2.1 to 9.2.8, 9.3.1 to 9.3.3, 9.3.5, 9.3.6, 9.4.1, 9.4.4, 9.4.5, 9.5.1, 9.5.2, 9.5.6, 9.6, 9.7.1 to 9.7.3, 9.7.5, 9.7.7, 9.7.9, 9.7.13, 9.7.15, 9.7.17, 9.10.1, 9.10.2 is mandatory. Compliance with other paras of the Section is recommended for the above ships.

9.1.3 For supply vessels of MODU /FOP with the descriptive notation "Supply vessel" intended for the transport of limited amounts of flammable liquids in bulk with a vapour flashpoint 60 °C and less the applicable requirements of the Section shall apply considering IMO resolution A.673(16) as amended.

For offshore support vessels intended for the transport of limited amounts of flammable liquids in bulk with a vapour flashpoint more than 60 °C the applicable requirements of paras listed in 9.1.2 shall apply.

The limited quantities of bulk liquids carried by offshore support vessels in the amount not exceeding a maximum shall be the lesser of 800 m<sup>3</sup> or a volume in cubic meters equal to 40 per cent of the vessel's deadweight calculated as a cargo density of 1000 kg/m<sup>3</sup>.

In case where offshore support vessels of MODU/FOP are intended for carriage of more than the relevant maximum amount specified above, the requirements for such vessels shall be similar in full scale to the requirements for the bulk carriers.

### 9.2 GENERAL REQUIREMENTS FOR PIPING IN CARGO AREA

9.2.1 Remote-controlled valves shall comply with the requirements of 4.1.1.2 to 4.1.1.4.

9.2.2 The spindles used to operate the valves placed inside the cargo tanks shall be carried to the open deck in gastight sealing glands. Replacement of the sealing shall be made from the open deck. The drives shall have arrangements showing whether the valve is open or closed. The drive shall be constructed as to prevent accumulation of oil residues in them.

Where the rubbing parts of the valve drives pass inside cargo tanks and cofferdams, as well as on the cargo deck, precautions shall be such as to preclude spark formation.

9.2.3 In enclosed spaces inside the cargo area, the temperature of steam or heating medium shall not exceed 220 °C.

9.2.4 The pipe flanges and fastening pieces intended for hose connections from shore installations shall be made of materials precluding spark formation.

9.2.5 The piping on deck and in cargo tanks shall be efficiently secured and fitted with thermal compensators. Where thermal expansion is compensated by pipe bends, the radii of pipe bends shall comply with the requirements of 2.2.

9.2.6 All the pipe lengths interconnected by flanges shall have reliable electric connection. At one place minimum, electric earthing to the hull shall be made as it is required in 2.5.3, Part XI "Electrical Equipment".

9.2.7 To prevent the passage of flame into cargo holds, in the structure of valves of cargo pipes and venting arrangements, covers of manholes and hatches of cargo tanks, use of materials, which easily lose their properties under the effect of heat, is not permitted.

9.2.8 In combination carriers, provision shall be made for devices in the form of blank flange to isolate slop tanks from cargo tanks.

9.2.9 All piping on board, through which communication between liquid-free spaces of cargo tanks is possible, shall be equipped with a flame arrester.

9.2.10 To keep cargo spills within the cargo area, provision shall be made for a permanent continuous coaming on the upper deck, of at least 300 mm in height and extending from side to side.

### 9.3 CARGO OIL SYSTEM

9.3.1 Cargo piping shall not pass through the tanks not intended for cargo storage and shall not be connected to other tanks or piping including the fuel oil pipes of the propulsion plant.

Cofferdams shall have no connections to cargo tanks. No by-pass valves are permitted in cofferdams.

The piping, by means of which hazardous mixing of different types of cargo or watering of cargo can take place, shall have a double number of shut-off valves.

9.3.2 The terminations of the filling pipes of cargo tanks shall be laid, as far as practicable, as near

to the tank bottom as possible, but not nearer than 1/4 of the pipe inner diameter.

**9.3.3** The slop tanks of oil tankers shall be generally served by independent piping systems. Where such systems are not provided, all the suction and discharge pipes of slop tanks shall be equipped with spectacle flanges or other blocking arrangements.

**9.3.4** In combination carriers, reliable means shall be provided for isolating the piping connecting the pump with the slop tanks.

The means of isolation shall consist of a valve followed by a spectacle flange or a spool piece with appropriate blank flanges. This arrangement shall be located adjacent to the slop tanks, but where this is unreasonable or impracticable, it may be located within the pump-room directly after the piping penetrates the bulkhead.

In combination carriers, under deck cargo piping shall be located in special ducts provided with ventilating and draining arrangements.

**9.3.5** In combination carriers where the ship is in the dry cargo mode, a permanently installed system shall be provided for discharging the contents of the slop tanks directly to the open deck. Use of spool pieces is permitted to connect the system for discharging the contents of the slop tanks to other systems.

The manifold for slop tank contents installed on the open deck shall be equipped with a shut-off valve and a blank flange.

**9.3.6** Where cargo hoses are connected to cargo manifolds, provision shall be made for a tray, in which cargo oil residues would accumulate.

**9.3.7** Irrespective of purpose, piping laid through dangerous zones and intended for hose connection from shore or from another ship, shall be provided with the following facilities to ensure intrinsic safety:

**.1** insulating flange connections or nonconducting pipe lengths;

**.2** insulating mats, pads and railing to prevent the contact between the metal components of hoses and the hull.

The measured resistance between the metal components of hoses and the hull shall not be less than 25 kOhm.

#### 9.4 CARGO PUMPS

**9.4.1** Cargo pumps and cargo stripping pumps shall serve only their direct purpose except as provided for in 7.7.1 and 9.10.2. These pumps shall not have any connections to tanks other than cargo tanks.

Cargo pumps and cargo stripping pumps shall be either installed in a separate space or they shall be submersible pumps.

**9.4.2** The arrangement of driving machinery of cargo pumps and cargo stripping pumps shall comply with the requirements of 4.2.5, Part VII "Machinery Installations".

**9.4.3** The design of pumps, valves and their drives shall be such as to preclude spark formation to maximum extent possible. Structural measures shall be taken to limit the zero delivery time of submersible cargo pumps.

**9.4.4** Devices shall be provided to stop cargo pumps and cargo stripping pumps from the top flat of the pump room at main deck level or from a readily accessible location on deck.

Where a cargo control station is provided, the pump stopping arrangements shall be installed at the cargo control station as well.

The stopping arrangements of electrically driven pumps shall comply with the requirements of 19.2.4.5, Part XI "Electrical Equipment".

**9.4.5** The pressure gauges of the cargo oil discharge and cargo stripping mains shall be fitted at pumps and on the top flat of the pump room, or at the cargo control station.

**9.4.6** Where any machinery (both electric and hydraulic) used to drive cargo and ballast pumps, as well as the arrangements used to supply and control the pumps and valves of the cargo and ballast systems are integrated, the requirements of 19.2.7, Part XI "Electrical Equipment" shall be met.

#### 9.5 BOW AND AFT LOADING SYSTEM

**9.5.1** Bow and aft cargo piping of an oil tanker shall be permanently installed. Where necessary, the connections of such piping may be detachable.

**9.5.2** Bow and aft cargo piping shall be laid outside accommodation and service spaces, and outside machinery spaces adjacent to accommodation spaces and control stations.

**9.5.3** Bow and aft cargo piping shall be connected by welded joints. If necessary, expansion joints may be used. Within the hazardous zone, piping may have detachable joints.

For pipe-to-valve connections, flange connections, as mentioned in 2.4, may be used. Cargo piping of this type shall be marked accordingly. They shall be disconnectable from the principal cargo mains either with two valves in the cargo area, provided with devices for their sealing when shut, or with a single valve used alongside a spool piece or spectacle flange.

**9.5.4** The pipe section used as shore connection shall be fitted with a shut-off valve and a blank flange, and provided with a tray. In case a special coupling is used, the blank flange may be omitted. The area of 3 m around the manifolds shall be considered a hazardous zone 1 (refer to 19.2.3, Part XI "Electrical Equipment").

**9.5.5** In cargo piping, arrangements for the discharge of cargo residues shall be provided. Outside the hazardous zone, cargo piping shall be fitted with arrangements to make it clean of cargo and purge it with inert gas. Between cargo piping and inert gas system, isolating device shall be fitted. For ships less than 8000 tons deadweight without an inert gas system, it is possible to provide ventilation of pipelines with a portable fan or compressed air blowing instead of purging with an inert gas.

**9.5.6** In oil tankers equipped with bow loading system intended for cargo-handling operations at point berths carried out to sea, an emergency high-speed device shall be installed for the cargo hose disconnection.

#### 9.6 CARGO HEATING SYSTEM

**9.6.1** As a heating medium for heating of cargo in tanks, the use of steam, hot water and thermal oil is permitted.

**9.6.2** Upstream from each steam heating coil, a non-return stop valve shall be fitted, and upstream to stop valves at the outlet the gauge valve for checking of the condensate quality shall be installed.

**9.6.3** The return of condensate from the heating system shall be performed via the check tank.

The air pipes of the check tank for heating steam condensate from the cargo tanks containing the cargoes with the flash point below 60 °C shall be provided with flame arresters and be lead to a safe place.

**9.6.4** Cargo heating systems using thermal liquid as a heating medium shall comply with 20.11.

**9.6.5** In ships with the descriptive notations "Oil tanker (>60 °C)" and "Oil/ore carrier (>60 °C)" in the class notation, the maximum heating temperature shall be lower than the flash point of the carrying cargo at least for 15 °C.

**9.6.6** The cargo heating system shall be equipped with the facilities for cargo temperature control in the tanks. Control of the current temperature in tanks, as well as light and audible alarms on exceeding of the maximum permissible cargo temperature or on cargo flow velocity loss when pumped through the heaters, shall be provided.

#### 9.7 VENTING SYSTEM

**9.7.1** The venting system shall ensure gas exchange and safe pressure in cargo tanks during the loading, discharging and carriage of liquid cargo. For this purpose, the system shall include one or more devices to limit the following:

.1 pressurization above cargo tank test pressure during loading or ballasting with the maximum specified output;

.2 pressure fall below 7 kPa during unloading with the maximum cargo pump delivery.

**9.7.2** The venting systems of cargo tanks shall be entirely distinct from the air pipes of other compartments.

The design and arrangement of the outlets of venting arrangements shall be such as to minimize the possibility of flammable vapours being admitted to enclosed spaces containing a source of ignition or collecting in the vicinity of deck machinery and equipment.

**9.7.3** The venting system shall include arrangements to provide for:

.1 free flow of small volumes of vapour, air or inert gas mixtures caused by thermal variations in the cargo tank;

.2 free flow of large volumes of vapour, air or inert gas mixtures during cargo loading and ballasting, or during discharging.

**9.7.4** Vent outlets for free flow of vapour mixtures, intended for compensation of thermal pressure variations, shall be arranged:

.1 not less than 2 m above the cargo tank deck;

.2 not less than 5 m from the nearest air intakes and openings to enclosed spaces containing a source of ignition and from deck machinery and equipment, which may constitute an ignition hazard, such as anchor windlass and chain locker openings.

**9.7.5** The venting arrangements in each cargo tank may be independent or combined with other cargo tanks and may be incorporated into the inert gas piping. Where the arrangements are combined with other cargo tanks, pressure/vacuum, valves may be mounted on the inert gas mains.

**9.7.6** Where the arrangements are combined with other cargo tanks, a stop valve and a flame arrester shall be provided to isolate each cargo tank. Where stop valves are fitted, they shall be provided with locking arrangements which shall be under the control of the responsible ship's officer. There shall be a clear visual indication of the operational status of the valves. Where tanks have been isolated, it shall be ensured that relevant isolating valves are opened before cargo loading or ballasting or discharging of those tanks is commenced.

Flame arresters shall be located so as to render the penetration of cargo oil therein impossible under any navigational conditions, rolling included.

**9.7.7** Any isolation of venting arrangements shall continue to permit the flow caused by thermal variations in a cargo tank in accordance with 9.7.3.1.

**9.7.8** The system for the venting of vapours displaced from the cargo tanks during loading, discharging and ballasting shall consist of either one or more mast risers, or a number of high-velocity vents permitting to discharge of the vapour mixtures with a velocity of not less than 30 m/s. The vapour mixture shall be discharged vertically upwards.

**9.7.9** The vent outlets of pipes required by 9.7.3.2 shall be designed on the basis of the maximum designed loading rate multiplied by a factor of at least 1,25.

When determining the capacity of venting systems equipped with flame arresters, the pressure drop as the gases pass through the flame arrester shall be considered. In any case, the adopted pressure drop value shall be by 50 per cent greater than that for a flame arrester in the clean condition.

The internal diameter of vent pipes shall not be less than 80 mm, and that of mains, not less than 100 mm.

**9.7.10** Where the method is by free flow of vapour mixtures, the vent outlets of the venting system pipes shall not be less than 6 m above the cargo tank deck or fore and aft gangway, if situated within 4 m of the gangway, and located not less than 10 m measured horizontally from the nearest air intakes and openings to enclosed spaces containing a source of ignition and from deck machinery, which may include anchor windlass and chain locker openings, and equipment which may constitute an ignition hazard.

**9.7.11** Where the method is by high-velocity discharge, the vent outlets shall be located at a height not less than 2 m above the cargo tank deck and not less than 10 m measured horizontally from the nearest air intakes and openings to closed spaces containing a source of ignition and from deck machinery, which may include anchor windlass and chain locker openings, an equipment which may constitute an ignition hazard.

**9.7.12** In each cargo tank a secondary means of allowing full flow relief of vapour, air or inert gas mixtures to prevent overpressure or underpressure in the event of failure of the arrangements mentioned in 9.7.3.2 shall be fitted.

Pressure/vacuum-breaking devices fitted on the inert gas system main may be utilised as the required secondary means of allowing full flow relief of vapour, air or inert gas mixtures where the cargo is homogenous or for multiple cargoes where the vapours are compatible and do not require isolation.

Alternatively, pressure sensors may be fitted in each tank protected by the arrangement specified in 9.7.3.2, with a monitoring system in the ship's cargo control room or the position from which cargo operations are normally controlled. Such monitoring equipment shall also provide an alarm and monitoring system which is activated by detection of overpressure or underpressure conditions within a tank.

For ships that apply pressure sensors in each tank as an alternative secondary means of flow relief of vapour, air or inert gas mixtures, the overpressure alarm actuation setting shall be above the pressure setting of the pressure/vacuum-valve and the underpressure alarm actuation setting shall be below the vacuum setting of the pressure/vacuum-valve. The alarm actuation settings shall be within the design pressures of the cargo tanks. The actuation settings of pressure and vacuum detectors in cargo tanks shall be fixed and not arranged for blocking or adjustment in operation. An exception is permitted for ships that carry different types of cargo and use pressure/vacuum valves with different settings, one setting for each type of cargo.

**9.7.13** Permanent arrangements shall be provided to drain the venting arrangements and vent lines to a cargo tank.

**9.7.14** The venting system shall be provided with devices to prevent the passage of flame into the cargo tanks.

The design, testing and locating of flame arresters shall comply with the requirements based on ISO 15364, IMO MSC/Circ.677 considering amendments (MSC/Circ.1009 and MSC/Circ.1324).

**9.7.15** The hatches and other openings of cargo tanks used for measuring temperature, ullage, sampling, gas analysis, except openings for permanently installed gauges, shall be provided with self-closing covers or valves. Flame arresters and screens are not required in these openings. The above covers and/or valves shall not be used for pressure equalization in the spaces above the cargo surface.

**9.7.16** Arrangements, required in 9.7.1.1, may be provided with a bypass arrangement when they are located in a vent main or masthead riser. Where such an arrangement is provided, there shall be suitable indicators to show whether the bypass is open or closed.

**9.7.17** In combination carriers, the arrangements for isolating venting systems of slop tanks containing oil or oil residues shall consist of blank flanges, which will remain in position at all times when cargoes other than liquid cargoes are carried.

**9.7.18** The venting systems of oil tankers designed to carry boiling oily products, the Reid vapour pressure of which exceeds atmospheric pressure, shall be subject to special consideration by the Register in each case.

### 9.8 PURGING AND GAS FREEING OF CARGO TANKS

**9.8.1** On the ships fitted with an inert gas system, arrangements may be provided for purging and gas freeing empty tanks in addition to the venting arrangements specified in 9.7.10 and 9.7.11, which would ensure an exit vertical velocity of at least 20 m/s when any three tanks are being simultaneously supplied with inert gas. Their outlets shall extend not less than 2 m above deck level.

**9.8.2** On the ships not fitted with an inert gas system, special fans, which may be portable, shall be provided for purging and gas freeing empty tanks. During gas freeing operations, in addition to the arrangements specified in 9.7.10 and 9.7.11, hydrocarbon vapours may be vented through special pipes, which shall comply with the following requirements:

the pipe outlets shall extend not less than 2 m above deck level;

gas exit velocity of at least 30 m/s in the vertical direction shall be maintained;

the pipe outlets shall be arranged horizontally not less than 10 m away from openings to enclosed spaces containing sources of ignition, from air intakes, deck machinery and other equipment which may present ignition hazard.

Gas exit velocity may be reduced to 20 m/s, provided the device is fitted to prevent the passage of flame, as required by 9.7.14.

**9.8.3** On individual cargo tanks, the gas outlet pipe shall be positioned as far as practicable from the inert gas/air inlet. The inlet of such outlet pipes may be located either at deck level or at not more than 1 m above the bottom of the tank.

**9.8.4** Each gas outlet shall be fitted with suitable blanking arrangements.

### 9.9 CARGO VAPOUR DISCHARGE SYSTEM

**9.9.1** If a ship is equipped with the cargo vapour discharge system, the distinguishing mark VCS may be added to the character of classification. In addition to the requirements of the present Chapter, in order to assign the distinguishing mark VCS to the ship, the requirements for the overflow prevention and cargo tank level control specified in 9.11.1 shall be complied with, and the level gauging system shall be closed as specified in 9.11.2. Fulfilment of the

*External view of the stud with a diameter of 12,7 mm in the place, which corresponds to direction of the hand showing 12 o'clock*

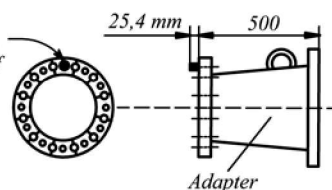

Fig. 9.9.11-1

above requirements and assignment of the above distinguishing mark confirm compliance of the system with the requirements of IMO MSC/Circ.585.

**9.9.2** The cargo vapour discharge system shall be arranged in such a way that it cannot interfere with the normal operation of the venting system.

The cargo vapour discharge system shall be designed basing on the maximum loading capacity. The pressure drop in the cargo vapour discharge piping, obtained by means of hydraulic calculation, shall not exceed 80 per cent of the opening pressure of any venting system discharge valve specified in 9.7.1.1.

**9.9.3** The instructions approved by the Register shall be constantly kept on the ship, proceeding from which the allowable loading speed of different cargoes may be defined, taking into consideration the requirements of 9.9.1 and 9.9.2.

**9.9.4** Vapours of incompatible cargoes shall not be mixed when passing the vapour discharge system.

**9.9.5** When the inert gas distribution piping is used to collect cargo vapours, measures shall be taken for insulating inert gas pipes from the cargo vapour discharge system.

**9.9.6** Provision shall be made for elimination of condensate, which may be accumulated in the system.

**9.9.7** Piping of the system shall be electrically continuous and have safety earthing.

**9.9.8** Cargo vapour discharge manifolds shall be fitted with a pressure sensor and alarm system to produce alarm signals at high-pressure level (but not higher than that at which the high-speed venting device is actuated) and for vacuum (but not lower than the pressure, at which the vacuum valve is actuated).

The present requirement may be dispensed with if each cargo tank is fitted with overpressure/underpressure sensor according to 9.7.12.

**9.9.9** In the area of the adapter sleeve of the cargo vapour discharge manifold, the easily accessible check valve with manual control shall be installed.

**9.9.10** Hoses applied in the vapour discharge system shall comply with the requirements of 6.1.12.

**9.9.11** To exclude false connection of vapour discharge piping to onshore terminal liquid cargo piping, studs with a diameter of 12,7 mm and the length not less than 25,4 mm shall be mounted on the vapour discharge manifold connecting flanges at the upper point of the coupling bolts line, as shown in Fig. 9.9.11-1. The vapour discharge manifold marking shall comply with Fig. 9.9.11-2.

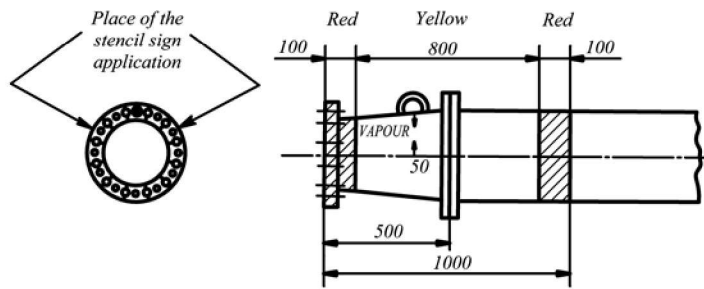

Fig. 9.9.11-2

### 9.10 SHIP SERVICE SYSTEMS IN CARGO AREA

**9.10.1** Ballast, sounding and air pipes of segregated ballast tanks shall not pass through cargo tanks. Cargo and similar pipes intended to serve cargo and slop tanks shall not be laid through segregated ballast tanks. This requirement may be dispensed with, in the case of shorter pipes, provided they are completely welded or equivalent, with thickened flanged connections, the number of which shall be kept to a minimum. Thermal expansion of the pipes shall be compensated by the pipe bends. The bend radii shall be in accordance with the requirements of 2.2.1. In Fig. 9.10.1, the recommended design of an air pipe is shown by way of an example. Piping shall be seamless and its material shall be steel. The pipe wall thickness shall not be less than indicated in Table 9.10.1.

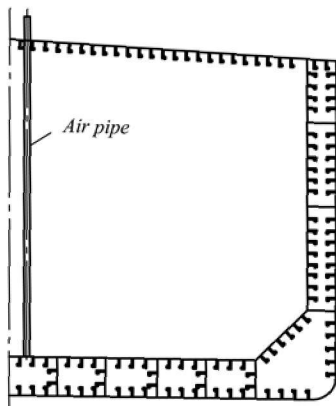

Fig. 9.10.1

**9.10.2** Emergency ballast discharge may be affected by means of a connection to a cargo pump through a spool piece, which shall be mounted in a conspicuous, readily accessible position in the pump

room. To prevent the passage of petroleum products into the ballast tanks, a non-return valve shall be fitted on the segregated ballast connections. The ballast pump shall be located in the cargo pump room or another space with the safety level equivalent to that of a cargo pump room not containing sources of ignition.

**9.10.3** The fore peak tank can be ballasted with the system serving other ballast tanks within the cargo area, provided:

- .1 the fore peak tank is considered as hazardous;
- .2 the vent pipe openings are located on open deck 3 m away from sources of ignition or in accordance with 19.2.3, Part XI "Electrical Equipment";
- .3 means are provided, on the open deck, to allow measurement of flammable gas concentrations within the fore peak tank by a suitable portable instrument;
- .4 the sounding arrangement to the fore peak tank is direct from open deck;
- .5 the access to the fore peak tank is direct from open deck. Alternatively, indirect access from the open deck to the fore peak tank through an enclosed space may be accepted provided that:

**.5.1** in case the enclosed space is separated from the cargo tanks by cofferdams, the access is through a gas tight bolted manhole located in the enclosed space and a warning sign shall be provided at the manhole stating that the fore peak tank may only be opened after it has been proven to be gas free; or any electrical equipment which is not certified safe in the enclosed space is isolated;

**.5.2** in case the enclosed space has a common boundary with the cargo tanks and is therefore hazardous, the enclosed space can be well ventilated.

**9.10.4** In oil tankers, the open ends of air pipes of cofferdams, fuel oil and lubricating oil tanks adjoining cargo and slop tanks shall be laid to the open deck where the vapours displaced from the above tanks do not present a fire hazard and where flame

Table 9.10.1

Internal diameter, in mm	Up to 50	Up to 100	Up to 125	Up to 150	150 and above
Minimal wall thickness, in mm	6,3	8,6	9,5	11,0	12,5

arresting fittings of a Register-approved type are available. The flow area of the fittings shall not be less than the air pipe area.

**9.10.5** Steaming pipes of cargo tanks shall be equipped with non-return/shut-off valves.

#### **9.11 LEVEL AND OVERFLOW CONTROL OF CARGO TANKS**

**9.11.1** Provision shall be made to guard against liquid rising in the venting system to a height, which would exceed the design head of cargo tanks. This shall be accomplished by high-level alarms or overflow control systems. The overflow control system shall be two-level and independent of tank level gauging devices, it shall give visible and audible high- and limit-level alarms in cargo tanks to the ship operator and to the cargo control room (if any), give and alarm for deenergization of the system or level sensors, have the possibility of checking the alarm circuit prior to cargo operations. For the purpose of this regulation, spill valves are not considered equivalent to an overflow system.

**9.11.2** Each oil tanker equipped with a fixed inert gas system shall be provided with closed measurement devices for taking ullages of cargo and slop tanks. In oil tankers, semiclosed or closed measurement devices for taking ullages of cargo and slop tanks shall be applied. Open sounding devices are admitted in oil tankers with the descriptive notation "Oil tanker (> 60 °C)" and as a reserve means in oil tankers not equipped with the inert gas system.

**9.11.3** The cargo tanks sounding pipes shall be so designed as to include hermetic self-closing valves and covers fitted on pipes laid to the open deck; the pipe laid to the deck shall be as high as to prevent cargo spillage onto the deck during sounding.

**9.11.4** In oil tankers intended for the carriage of cargoes with flash point below 60 °C, the sounding rods shall be made of a non-sparking material.

**9.11.5** In oil tankers each cargo tank shall be provided with overflow prevention system to meet the following requirements:

- .1 be separated of sounding system of cargo tanks;
- .2 give visible and audible high- and limit-level alarms in cargo tanks to ship's operator and to cargo handling room;
- .3 give an alarm on de-energization of system or level sensors;
- .4 have the possibility of checking the alarm circuit prior to cargo operations;
- .5 give a code signal for sequential switch-off of shore pumps and valves, or both, and valves shall be switched off by ship's operators. Application of ship's automatically closed valves is allowed only

upon the permission and under the agreement with Port Administration.

#### **9.12 CARGO TANK WASHING SYSTEM**

**9.12.1** Fixed tank washing machines shall comply with the following requirements:

.1 during the operation of the machines or with the machines immersed in fluid, any induced stresses both in the machine piping and deck connections shall not exceed the permissible values;

.2 support attachments and footing of the machines shall be approved by the Register;

.3 the machines shall be made of steel or any other material, which tendency to sparking during friction is not greater than that of steel;

.4 the complete installation shall be permanently earthed to the ship hull.

**9.12.2** The casing of portable washing machines shall be made of a material, which would not spark when in contact with cargo tank structures. Secure electrically conductive coupling shall be ensured among the tank washing machine, hose and permanent washing water main. Hoses for washing with portable washing machines shall be armed with wire.

**9.12.3** After washing, the water shall be discharged to the sludge tank through an opening located not less than 1 m below the water level. The free fall of liquid to the sludge tank containing washing water and oil residues shall be impossible. The requirements of this paragraph may be waived where the sludge and cargo tanks are inerted.

**9.12.4** Every crude oil tanker of 20000 t deadweight and above shall be provided with the crude oil washing system. This system shall fully comply with the requirements of regulation 33 of Annex I to MARPOL 73/78. If a ship is provided with the crude oil washing system complying with the requirements of the above regulation, regardless of its deadweight, the distinguishing mark COW shall be added to the character of classification (refer to 2.2.18, Part I "Classification"). When the crude oil washing system is provided on board, the ship shall be fitted with the inert gas system complying with the requirements of 9.16. The crude oil washing system pipelines and associated equipment and arrangements (piping, tank washing machines, pumps, stripping system) shall comply with the Specifications for the Design, Operation and Control of Crude Oil Washing Systems in compliance with the provisions of IMO resolution A.446(XI), as amended by IMO resolutions A.497(XII) and A.897(21). The crude oil washing system shall consist of fixed pipelines and shall be independent of other systems. Sections of the

ship's cargo system may be incorporated into the crude oil washing system provided they meet the requirements applied to the crude oil washing system pipelines.

**9.12.5** The crude oil washing system pipelines and valves shall be of steel or other equivalent material and shall be of adequate strength at working pressure as for pipelines specified in 2.6.6. The pipelines shall be properly jointed and supported. After installation on board the ship the crude oil washing system shall be tested by the test hydraulic pressure of 1,5 of the working pressure.

**9.12.6** The washing water heater shall be located outside the engine room, if it is permanently connected by pipe with the crude oil washing system. Where the heater and washing water supply source are located in the engine room and arranged so that they can be connected to the tank washing system only when the system is completely and effectively isolated from the cargo system, the heater and supply source are not considered as part of the crude oil washing system. Arrangements for connection to the tank washing system shall be located in the cargo area.

**9.12.7** The pumps supplying crude oil to the tank washing machines may be either the cargo pumps or pumps specifically provided for the purpose.

The design of the pumps shall comply with the requirements of 9.4, Part VIII "Systems and Piping" and 5.2, Part IX "Machinery". The capacity of the pumps shall be sufficient to provide the necessary throughput at the rated pressure for the maximum number of tank washing machines to operate simultaneously. In addition to the above requirement, the pumps shall, if an eductor system is fitted for tank stripping, be capable of supplying the eductor driving liquid. The capacity of the pumps shall be such that the tank washing operations can be effectively carried out with any pump out of order.

**9.12.8** The stripping pipelines shall be fitted with valves or other shut-off devices for isolating each tank not being stripped at that particular time. The stripping system shall be capable of removing oil at a rate of 1,25 of the total throughput of all tank washing machines to operate simultaneously. Where the stripping system is provided with stripping pumps, the equipment for monitoring their operation shall include either a flow indicator, or a stroke counter or a revolution counter, as appropriate, depending on the pump type, as well as pressure gauges at the inlet and discharge connections or equivalent. Where eductors are provided, the monitoring equipment shall include pressure gauges at the driving liquid intake and discharge, as well as at the intake pipeline. All such monitoring equipment shall have remote read-out facilities in the cargo control room or in some other place easily accessible to the personnel in charge of crude oil washing operations.

**9.12.9** Provision shall be made to drain all cargo pumps and pipelines by means of the stripping system to cargo or slop tanks or to reception facilities. To discharge all cargo pipelines and pumps to reception facilities, a special small diameter pipeline shall be provided connected outboard of the ship's manifold valves as shown in Fig. 9.12.9. The cross-sectional area of the small diameter pipeline shall not exceed 10 per cent of the cross-sectional area of the cargo main.

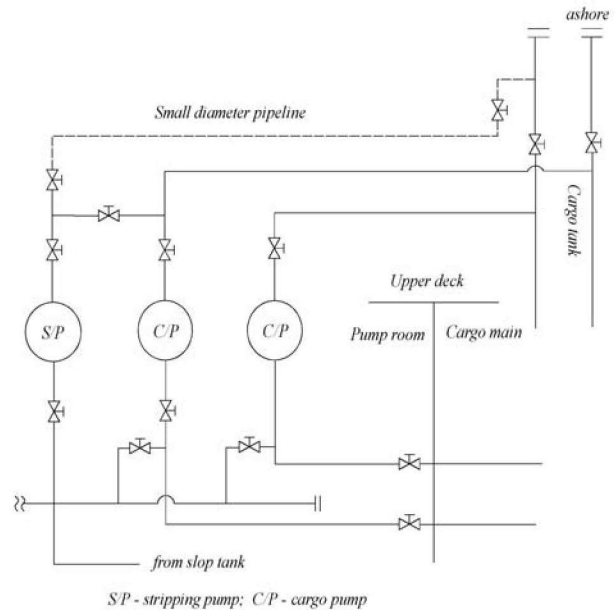

Fig. 9.12.9 Connection of the small diameter pipeline to the ship's manifold valve

**9.12.10** In oil tankers having in each tank individual cargo pumps with an independent piping system and an installation with a submerged cargo pump providing for a system to remove oil residues, the special small diameter pipeline may not be fitted if the total quantity of oil in tank after stripping and oil in pipes between the ship's manifold and tank is less than 0,00085 of the cargo tank capacity.

### 9.13 STATIC ELECTRICITY PROTECTION

**9.13.1** Cargo hoses, compressed air hoses, tank washing hoses and other hoses used in the cargo area shall comply with the requirements of Section 6, conduct electricity through their whole length, including connections and flanges (with the exception of shore connections), and shall be earthed to remove electrostatic charges.

**9.13.2** Portable pumps and ventilators to be used in the cargo area shall be equipped with devices for electrostatic earthing prior to operation.

**9.13.3** The cargo system shall make it possible to regulate the intensity of loading each particular tank so that the flow velocity would not exceed 1 m/s at suction pump outlet in the tank at the initial stage of loading. The above flow velocity can be increased, if cargo tanks are fitted with special suction wells to reduce the level of tank atmosphere electrization, which design shall be approved by the Register. For maximum loading intensity, the flow velocity shall not exceed 7 m/s. The requirements of this paragraph may be waived, if cargo tanks are inerted during cargo-handling operations.

#### 9.14 MONITORING THE COMPOSITION OF ATMOSPHERE IN CARGO AREA

**9.14.1** Oil tankers and combination carriers shall carry at least two portable instruments for measuring oxygen and flammable vapour concentrations (refer to item 15 of Table 5.1.2, Part VI "Fire Protection").

**9.14.2** Structural measures shall be taken to facilitate flammable vapour concentration measurements in all spaces of the cargo area. The above measurements shall be possible from open deck or readily accessible locations. Where the atmosphere in double hull spaces cannot be reliably measured using flexible gas sampling hoses, such spaces shall be fitted with permanent gas sampling lines. Where plastic pipe material are used, they shall be electrically conductive.

**9.14.3** In cargo pump rooms and in ballast pump rooms fitted with the equipment containing cargo a system for continuous monitoring of the concentration of hydrocarbon gases shall be fitted. Sampling of atmosphere for analysis shall be carried out in succession (including the exhaust vent). The interval between measurements shall be as short as possible. Detector heads of gas analyzers shall be located in the areas with limited air circulation (at recesses and remote angles). When the hydrocarbon gas concentration reaches a pre-set level, which shall not be higher than 10 per cent of the lower flammable limit, a continuous audible and visual alarm signal shall be automatically effected in the pump-room, main machinery control room, cargo control room and navigation bridge to alert personnel to the potential hazard.

In combination carriers, such system, in addition to the cargo pump-rooms, shall be installed in cofferdams and pipe tunnels adjacent to the settling tanks.

**9.14.4** Where fixed gas analysers are fitted outside the cargo area, the following conditions shall be met:

.1 sampling pipes shall be provided with flame arresters and gas samples shall be vented to the atmosphere through a special pipe mounted at a safe location;

.2 sampling pipe assemblies at gastight bulkhead penetrations shall be type-approved and their fire resistance shall be equal to that of the bulkhead;

.3 each sampling pipe shall be provided with a manual insulation valve fitted on the gas-safe side of the gastight bulkhead;

.4 instruments and equipment for gas analysis shall be arranged inside a special hermetic steel cabinet and one of the sampling points shall be located in the cabinet. When the dangerous gas concentration inside the cabinet reaches 30 per cent of the lower flammability limit, the gas supply to the gas analyzer shall be automatically stopped;

.5 sampling lines shall not generally be laid through spaces outside the hazardous area. Where it is not possible to install the gas analysis cabinet on a gastight bulkhead, the sampling pipes shall be as short as practicable, they shall be made of steel or an equivalent material and shall not have detachable joints except joints with the gas analysis cabinet and insulating valves on the gastight bulkhead.

**9.14.5** In oil recovery ships and bilge water removing ships the sampling arrangements or the atmosphere monitoring system detectors shall be located as follows:

.1 near the forced ventilation openings;

.2 at least at two locations at the open deck at a height not more than 1m above the deck;

.3 in machinery spaces of category A;

.4 in air locks;

.5 in cofferdams adjacent to cargo tanks.

**9.14.6** Oil tankers of 20 000 t deadweight and above shall be provided with a fixed hydrocarbon gas detection system of all double hull spaces complying with the Fire Safety Systems Code and the IMO Circular MSC.1/Circ.1370:

.1 the above system shall perform periodical measurements of hydrocarbon gas concentrations in all ballast tanks and void spaces adjacent to the cargo and slop tanks (inter alia to those, which form a cruciform (corner to corner) contact), including the forepeak tank and any other tanks and spaces under the bulkhead deck adjacent to cargo tanks. However, this is not required for fuel tanks;

.2 as a rule, the gas detection system shall be arranged with single sampling lines from each sampling point. Sampling lines in the same space may be combined at deck level with a manually operated three-way valve arrangements provided with clear local indication of which sampling point is active. In ballast/partially ballast condition valve to be set so that upper sampling point is active; for empty tank the lower sampling point is to be active;

.3 hydrocarbon gas concentration measurement systems should also be provided in ballast pump rooms and bow thruster rooms located under the bulkhead decks as well as in any void spaces adjacent to cargo and slop tanks. In such spaces it is permitted to arrange one sampling point at the lower part;

.4 it is not required to install fixed hydrocarbon gas detection equipment in the spaces of oil tankers fitted with permanently operated inert gas system for such spaces;

.5 cargo pump rooms complying with the requirements of 9.14.3 and 9.14.4 are not covered by the requirements of this paragraph.

#### 9.15 OIL RECOVERY SYSTEM OF OIL RECOVERY SHIPS

**9.15.1** The system and devices for the recovery and transfer of oil shall be installed outside machinery spaces and accommodation spaces.

**9.15.2** The system shall ensure both the recovery and transfer of oil being recovered.

**9.15.3** Where, in multi-purpose ships, a permanently installed oil recovery system is incompatible with the cargo of the cargo system installed, relevant isolating arrangements shall be provided.

**9.15.4** Where the ship is fitted with portable oil recovery equipment, not more than two suctions connected by piping to all oil collecting tanks shall be provided on the upper deck for connecting to the discharge hoses of the oil recovery equipment.

The arrangement of suctions on the upper deck shall make it possible to simultaneously connect two oil recovery systems installed on the opposite sides of the oil recovery ship.

Pipe connecting suctions to tanks shall not pass through accommodation, service spaces and other enclosed safe-type spaces (refer to 19.2.3.4 of Part XI "Electrical Equipment"), located as high as the open deck and above.

#### 9.16 INERT GAS SYSTEM (IGS)

##### 9.16.1 General.

**9.16.1.1** Oil tankers of 8000 t deadweight and above, intended for the carriage of flammable liquids with a flash point of 60 °C and below, as well as oil tankers provided with the crude oil washing system shall be equipped with the fixed inert gas system complying with the requirements of International Code for Fire Safety Systems with IMO resolution MSC.367 (93), 9.16.8, 9.16.9 or 9.16.12 with a capacity specified in 9.16.2. Where a ship is equipped with the inert gas system complying with the requirements of the present Chapter, the distinguishing mark IGS-IG, IGS-NG or IGS-Pad

may be added to the character of classification as specified in 2.2.17, Part I "Classification".

**9.16.1.2** The inert gas system may be used for fire prevention by generating and continually maintaining the non-flammable atmosphere in cargo tanks, except when such tanks shall be degassed. The system shall be capable of:

.1 maintaining the atmosphere in any part of any cargo tank with an oxygen content not exceeding 8 per cent by volume and at a positive pressure at all times in port and at sea except when it is necessary for such tank to be gas free;

.2 eliminating the need for air to enter a tank during normal operations except when it is necessary for such a tank to be gas free;

.3 purging empty cargo tanks with inert gas and air.

**9.16.1.3** Inert gas with an oxygen content of not more than 5 per cent by volume shall be delivered to the cargo tanks.

**9.16.1.4** The temperature of the inert gas supplied to cargo tanks shall be not in excess of 65 °C.

**9.16.1.5** The inert gas supply may be treated flue gas from main or auxiliary boilers or separate gas generators. The Register may accept systems using flue gases from other sources or any combinations thereof provided an equivalent standard of safety is achieved. Each source of flue gas shall be provided with automatic combustion control to provide for the fulfilment of the requirement of 3.9.1.3.

Carbon dioxide smothering system due to the risk of ignition of the mixture of vapours of flammable liquids with air from discharges of static electricity generated at carbon dioxide supply shall not be used for the purpose of inertization.

##### 9.16.2 Capacity.

**9.16.2.1** For ships specified in 9.16.1.1 and having the distinguishing mark IGS-IG or IGS-NG, the inert gas system shall have a capacity of not less than 125 per cent of the maximum total capacity of cargo pumps during discharging the ship.

**9.16.2.2** For ships not specified in 9.16.1.1 and having the distinguishing mark IG-Pad, the inert gas system shall have capacity sufficient for producing pad in cargo tanks, inerting, where necessary, of spaces adjacent to cargo tanks, replacing the inert gas loss during voyage, or the appropriated quantity of the inert gas in cylinders shall be provided on board the ship.

##### 9.16.3 Equipment.

**9.16.3.1** A flue gas scrubber shall be fitted which will effectively cool the volume of gas and remove solids and sulphur combustion products. The cooling water shall be delivered by an independent pump. Provision shall be made for an alternative supply of cooling water from a stand-by pump without interfering with any essential services on the ship.

**9.16.3.2** The gas scrubber shall be designed so that the capacity of the system will not drop for more than 3 per cent and the gas temperature at the outlet will not rise more than 3 °C as against the design values under all normal conditions of heel and trim.

**9.16.3.3** Provision shall be made in the gas scrubber housing for inspection holes and sight glasses made of impact-, and heat-resisting material for inspections and maintenance.

**9.16.3.4** At least two blowers shall be fitted which together are capable of delivering at least the volume of gas required by 9.16.2; and where possible there shall be established equal supply for each blower, but at any rate for each of them it shall not be less than 1/3 of aggregate required supply.

**9.16.3.5** Provision shall be made in the blower casing for maintenance devices.

**9.16.3.6** Interior surfaces of the scrubber and blowers shall be made of corrosion-resistant materials or lined with a coating material.

**9.16.3.7** Filters or equivalent devices shall be fitted to minimize the amount of water and solid particles carried over to the inert gas blowers.

**9.16.4** Cargo tank protection against pressure/vacuum.

**9.16.4.1** The inert gas system shall be so designed that the maximum pressure which it can exert on any cargo tank will not exceed the test pressure of any cargo tank.

**9.16.4.2** One or more devices for braking pressure/vacuum in cargo tanks shall be provided on the inert gas supply main if they are not fitted on the gas venting system or individually in each tank. Control and location of these arrangements shall comply with the requirements of 9.7.

**9.16.4.3** A positive pressure not exceeding 21 kPa shall be maintained in the cargo tanks when they are filled or being filled with inert gas under normal working conditions.

**9.16.5** Non-return devices.

**9.16.5.1** At least two non-return devices shall be fitted in the inert gas supply main in the cargo area on deck. One of them shall be a deck water seal, and the other — a non-return valve or an equivalent device fitted forward of the deck water seal. They shall be located between the automatic valve required by 9.16.6.5 and the aftermost connection to any cargo tank or cargo pipeline.

**9.16.5.2** The deck water seal shall be capable of being supplied by two separate pumps, each of which shall be capable of maintaining an adequate supply at all times and automatically starting each pump feeding the water seal and automatically filling the seal with water upon inert gas supply failure (for half-dry and dry water seals).

A drain pipe of the deck water seal shall not pass through machinery spaces. Discharge pipes shall be laid directly overboard.

**9.16.5.3** Provision shall be made to ensure that the water seal is protected against freezing in such a way that the integrity of seal is not impaired by overheating.

**9.16.5.4** The deck water seal and all loop arrangements shall be capable of preventing return of hydrocarbon vapours at a pressure equal to the test pressure of the cargo tanks.

**9.16.5.5** The non-return valve (refer to 9.16.5.1) may be of non-return shut-off type or of non-return type with a shut-off valve being additionally fitted in the inert gas supply main forward of the non-return valve.

**9.16.5.6** A water loop or other approved arrangement shall be fitted to each associated water supply and drain pipe and each venting or pressure-sensing pipe leading to gas safe spaces<sup>1</sup>. Means shall be provided to prevent such loops from being emptied by vacuum.

**9.16.5.7** Provision shall be made in the deck water seal for sight holes and glasses for monitoring the water level and making inspections.

**9.16.5.8** Materials used in non-return devices shall be resistant to the effect of acids generated during cooling, cleaning and by gases coming through the pipes.

**9.16.6** Pipes.

**9.16.6.1** The inert gas main may be divided into two or more distributing pipes forward of the non-return devices required by 9.16.5.1.

**9.16.6.2** The distribution inert gas supply pipes shall be fitted with branch piping leading to each cargo tank. Branch piping for inert gas shall be fitted with either shut-off valves or equivalent means of control for isolating each tank.

Where shut-off valves are fitted, they shall be provided with locking arrangements to prevent the control of the valves by unauthorized persons.

The control system operated shall provide positive indication of the operational status of the shut-off valves.

**9.16.6.3** In combination carriers the arrangement to isolate the inert gas system from the slop tanks shall consist of blank flanges.

**9.16.6.4** Pipe outlets discharging inert gas into the cargo tanks shall be located in the upper part.

**9.16.6.5** A gas regulating valve shall be fitted in the inert gas supply main. It shall be capable of automatically regulating the flow of inert gas to the cargo tanks as referred to in 9.16.8.8 unless means are provided to automatically control the speed of the inert gas blowers.

**9.16.6.6** If a connection is fitted between the inert gas supply main and the cargo system, arrangements

<sup>1</sup>Gas safe space is a space in which the entry of hydrocarbon gases would produce hazards with regard to flammability or toxicity.

shall be made to ensure an effective isolation having regard to the large pressure difference which may exist between the systems. It shall consist of two shut-off valves, the valve on the cargo main being of a non-return type, and an arrangement to vent the space between the valves in a safe manner or an arrangement consisting of a spool-piece with associated blanks.

**9.16.6.7** Piping systems shall be so laid as to prevent the accumulation of cargo or water in the pipelines under all normal conditions.

**9.16.6.8** Suitable arrangements shall be provided for the safe venting of the section of the line between the valves referred to in 9.16.5.5 and 9.16.6.5 in case when the first of these valves is closed.

**9.16.6.9** The diameter of the pipes shall be such as to ensure the gas flow rate in any section of the piping to be not more than 40 m/s.

**9.16.6.10** The piping from the gas scrubber to the blowers and recirculation lines as well as drain pipe of gas scrubbing and cooling system shall be lined with corrosion-resistant coating.

**9.16.6.11** An arrangement shall be provided to connect the inert gas main to the external supply of inert gas. The arrangement shall consist of a branch with a flange joint DN 250 mm fitted forward of the non-return valve specified in 9.16.6.5.

Flange design shall comply with the requirements of 2.4.3.

**9.16.6.12** The inert gas supply main may be used for the venting of the cargo tanks.

#### **9.16.7 Instruments and alarms.**

**9.16.7.1** On the discharge side of gas blowers, instruments shall be provided for continuous indication of the inert gas temperature and pressure.

**9.16.7.2** Instrumentation shall be fitted for continuously indicating and permanently recording, when the inert gas is being supplied:

**.1** the pressure of the inert gas supply main forward of the non-return devices required by 9.16.5.1;

**.2** the oxygen content of the inert gas in the inert gas supply main on the discharge side of the gas blowers.

These devices shall be placed in the cargo control room; but where no cargo control room is provided, they shall be placed in a position easily accessible to the officer in charge of cargo operations.

**9.16.7.3** In addition to the requirements of 9.16.7.2, the following meters shall be fitted:

**.1** in the navigation bridge to indicate at all times the pressure (refer to 9.16.7.2.1) and the pressure in the slop tanks of combination carriers, wherever those tanks are isolated from the inert gas supply main;

**.2** in the main machinery control room or in the machinery space to indicate the oxygen content (refer to 9.16.7.2.2).

**9.16.7.4** Suitable arrangements shall be provided on each cargo tank for measuring oxygen and hydrocarbon vapour concentration using portable instruments.

**9.16.7.5** Suitable means shall be provided for the zero and span calibration of both fixed and portable gas concentration measurement instruments referred to in 9.16.7.2 and item 15 of Table 5.1.2, Part VI "Fire Protection".

**9.16.7.6** Audible and visual alarms shall be provided to indicate:

**.1** low water pressure or low water flow rate to the flue gas scrubber;

**.2** high water level in the scrubber;

**.3** increase of gas temperature, this alarm being operated when the temperatures referred to in 9.16.1.4 are reached;

**.4** failure of inert gas blowers;

**.5** oxygen content more than 14 per cent by volume in cargo holds;

**.6** oxygen content in the inert gas main more than 8 per cent by volume;

**.7** failure of the power supply to the automatic control system for the gas regulating valve and to the indicating devices referred to in 9.16.7.2;

**.8** low water level in the deck water seal referred to in 9.16.5.1;

**.9** gas pressure less than 1 kPa in the inert gas main. The alarm arrangement shall be such as to ensure that the pressure in slop tanks in combination carriers can be monitored at all times;

**.10** high gas pressure (when the pressure reaches 10 kPa);

**.11** insufficient fuel feeding (if inert gas generators are available);

**.12** failure of power supply to the generator (if inert gas generators are available);

**.13** failure of power supply to automatic generator control system (if inert gas generators are available).

**9.16.7.7** Indicating units of the alarms required in 9.16.7.6.3, 9.16.7.6.4, 9.16.7.6.6 and 9.16.7.9 shall be placed in the machinery space and in the cargo control room, where provided, but in any case they shall be placed in a position where the alarm may be immediately received by responsible members of the crew.

**9.16.7.8** Audible and visual alarms indicating the low water level in the water seal of half-dry and dry type shall operate on failure of the inert gas supply.

**9.16.7.9** Additional audible alarms independent of the alarms required in 9.16.7.6.9 or automatic shut-down of the cargo pumps shall be provided to operate when the pressure in the main drops to 0,5 kPa.

**9.16.8** Systems using flue gas of boilers (these requirements are additional to those of 9.16.1 to 9.16.7).

**9.16.8.1** The flue gas scrubber and blowers shall be located aft of all cargo tanks, cargo pump rooms and cofferdams separating these spaces from machinery spaces of category A.

The design and location of scrubber and blowers with relevant piping and valves shall prevent the gas leakages into enclosed spaces.

**9.16.8.2** Suitable shut-off arrangements shall be provided on the suction and discharge connections of each blower. Arrangements shall be provided to enable the functioning of the inert gas plant to be stabilized before commencing cargo discharge.

**9.16.8.3** Shut-off valves shall be fitted in the inert gas supply mains between the boiler uptake and the flue gas scrubber. The valves shall be provided with an indicator to show whether they are open or shut. Precautions shall be taken to maintain them gastight and keep the seatings clear of soot.

Arrangements shall be provided to ensure that boiler soot blowers cannot be operated when the corresponding flue gas valve is open.

**9.16.8.4** If the blowers shall be used for gas freeing, their air inlets shall be provided with blanking arrangements.

**9.16.8.5** A shut-off valve (refer to 9.16.8.3) shall be made of materials capable of withstanding the flue gas temperature and resistant to the corrosive action of the gas.

**9.16.8.6** The piping between the shut-off valve and the scrubber shall be made of corrosion-resistant steel.

**9.16.8.7** An additional water seal or other effective means of preventing flue gas leakage shall be fitted between the shut-off valve (refer to 9.16.8.3) and the scrubber.

**9.16.8.8** The valve referred to in 9.16.6.5 shall be located at the forward bulkhead of the forwardmost gas safe space through which the inert gas supply main passes.

**9.16.8.9** Automatic shutdown of the inert gas blowers and gas regulating valve shall be arranged on predetermined limits being reached in respect of 9.16.7.6.1, 9.16.7.6.2 and 9.16.7.6.8. Automatic shutdown of the gas regulating valve shall also be arranged in case of blower failure.

**9.16.9** Inert gas generator system (the requirements for this system stated below are additional to those given in 9.16.1 to 9.16.7).

**9.16.9.1** For inert gas generator (the machinery including blower, combustion chamber, scrubber, fuel oil pump, burner, automatic combustion control and supervisory equipment) use shall be made of fuel oil meeting the requirements of 1.1.2, Part VII "Machinery Installations".

**9.16.9.2** The generators shall be located in the space referring to machinery spaces of category A.

**9.16.9.3** In ships in whose tanks toxic substances may be carried the gas generators shall not be located in the machinery spaces and shall be located in a compartment reserved solely for their use according to the requirements of 9.16.8.1. Such a compartment shall be separated from the machinery spaces at least by a gastight steel bulkhead, having no doors or other openings, and from the accommodation spaces and cargo area by open decks, cofferdams or similar spaces. Adequate positive pressure type mechanical ventilation shall be provided for such a compartment. Access to such compartments shall be only from an open deck outside the cargo area. Access shall be provided on the end bulkhead of the superstructure or deckhouse, not facing the cargo area and/or on the outboard side of the superstructure or deckhouse at a distance of at least  $L/25$ , but not less than 3 m from the end of the superstructure or deckhouse facing the cargo area.

The inert gas supply main shall not be located in, or have any connection with systems located in machinery spaces, accommodation spaces and service spaces.

**9.16.9.4** Despite the provisions of 9.16.3.4, the Register may permit only one blower if it is capable of delivering to the protected cargo spaces the total volume of gas required by 9.16.2, provided sufficient spares for the air blower and its prime mover are carried on board to enable any failure of the air blower and its prime mover to be rectified by the ship's crew.

**9.16.9.5** Two fuel oil pumps shall be fitted to the inert gas generator. The Register may permit only one fuel oil pump, provided sufficient spares for the fuel oil pump and its prime mover are carried on board to enable any failure of the pump and its prime mover to be rectified by the ship's crew.

**9.16.9.6** Where more than one inert gas generator is provided, suitable shut-off arrangements shall be fitted on the discharge outlet of each generator plant.

**9.16.9.7** Arrangements shall be made to vent the inert gas to the atmosphere during starting-up or in case of equipment failure.

**9.16.9.8** Where the inert gas generator is served by positive displacement blowers, a pressure relief device shall be provided to prevent excess pressure being developed on the discharge side of the blower.

**9.16.9.9** Audible and visual alarms shall be provided to indicate:

- .1 insufficient fuel oil supply;
- .2 failure of power supply to the generator;
- .3 failure of power supply to the automatic control system for the generator.

**9.16.9.10** The gas regulating valve shall be automatically controlled to close and to interrupt the fuel oil supply to the generator on predetermined limits being reached in respect of 9.16.7.6.1 and 9.16.7.6.2.

Automatic shut-down of the gas regulating shall also be arranged in respect of 9.16.9.9.2.

**9.16.10 Inertization of oil tankers double hull spaces.**

**9.16.10.1** On tankers, where the inert gas system is provided, inertization of space in double hull may be accomplished through detachable branch pipes connected with the inert gas system of cargo tanks or via stationary pipelines. If detachable branch pipes are used, connection arrangements on the system main shall be provided.

**9.16.10.2** If stationary pipelines are used, measures shall be provided to mitigate inert gases return from the protected space into IGS like two non-return devices compliant to 9.16.5. It is recommended that a separate deck gate and shut-off valve shall be provided.

**9.16.10.3** Inert gas by-pass is prohibited from cargo tanks into other protected spaces including ballast tanks and back.

**9.16.10.4** Measures shall be provided to avoid the ingress of water into IGS pipes from ballast tanks in case of their overfilling.

**9.16.10.5** At the inert gas supply piping to a ballast tank or another protected space an isolation stop valve shall be provided.

**9.16.10.6** Special measures shall be taken to prevent overpressure or vacuum in ballast tanks both as a result of the system of inert gas, and as a result of the ballast pump.

**9.16.10.7** If the inert gas system (IGS) is an alternative for a fixed hydrocarbon gas detection system as required in 9.14.6.4, then the inert gas system (IGS) shall be permanently operated. Its capacity shall be not less than 125 per cent of the maximum total supply of cargo and ballast pumps if in compliance with the ship procedures simultaneous ballast and cargo discharging is provided. In case combination of such operations is not provided, IGS capacity shall be at least 125 per cent of the maximum total supply. If an individual IGS is provided for ballast tanks onboard, its capacity shall be at least 125 per cent of the maximum consumption during ballast discharging. In the event of failure of the onboard system portable concentration measurement devices in protected spaces.

All ballast tanks and void spaces of double hull and double-bottom spaces adjacent to the cargo tanks, including the forepeak tank and any other tanks and spaces under the bulkhead deck adjacent to cargo tanks, except cargo pump-rooms and ballast pump-rooms, shall be fitted with suitable connections for the supply of inert gas.

**9.16.11 System for producing pad in cargo tanks.**

**9.16.11.1** To produce pad in cargo tanks, use may be made of the system with the inert gas supplied from cylinders, as well as the system using inert gas

generators and nitrogen generators, if their capacity is less than that specified in 9.16.2.1. The quantity of gas in the cylinders shall be sufficient for producing pad in cargo tanks, inerting, where necessary, of spaces adjacent to cargo tanks and for replacing the inert gas loss during voyage.

**9.16.11.2** The inert gas shall be stored in special cylinders or pressure vessels complying with the requirements of Part X "Boilers, Heat Exchangers and Pressure Vessels". The pressure vessels may be installed on the open deck or in a special space complying with the requirements of 3.1.3.2, Part VI "Fire Protection", located aft of the collision bulkhead and provided with ventilation complying with the requirements of 12.9.

**9.16.11.3** Pipelines from pressure vessels and from each group of cylinders shall be fitted with reducing valves downstream of which safety valves shall be provided. Besides, two non-return valves placed in tandem shall be provided. Otherwise, all connections of the system to protected spaces and pipelines shall be provided with detachable components. Shut-off valves shall be provided upstream and downstream of these components.

**9.16.11.4** Cargo tanks and the spaces to be inertized (specified in 9.16.10.1) shall be equipped with devices for measuring pressure and gas atmosphere.

**9.16.12 Nitrogen generator system.**

**9.16.12.1** The present requirements cover the system in which the inert gas (nitrogen) originates at separation of compressed air to the basic gases while passing through the nitrogen generator (group of empty fibres of semipermeable membranes or through adsorbent placed in hermetic casing). In addition to the requirements of the present paragraph, the system shall also comply with requirements 9.16.2.1, 9.16.4, 9.16.6.1 to 9.16.6.4, 9.16.6.12 (applicable to 9.16.12.8), 9.16.7.4, 9.16.7.5, 9.16.7.9 (applicable to 9.16.12.14.7) and 9.16.8.8 (applicable to 9.16.12.8).

**9.16.12.2** Air compressor and nitrogen generator shall be placed in the engine room or in a separate room which is then referred to other engine rooms (refer to 2.4.2, Part VI "Fire Protection"). It shall be located outside the cargo area and it shall have no direct access to the accommodation, service spaces and control stations.

**9.16.12.3** The system shall produce inert gas with at least 95 per cent content of nitrogen and no more than 5 per cent of oxygen. The system shall be fitted with an automatic device which would enable emission of gas into the air while preparation of the system for the specification level and even during its faults.

**9.16.12.4** The system shall have two air compressors of equal capacity. The system may have one compressor provided there are enough spare parts for it aboard to repair by the crew.

**9.16.12.5** Equipment for processing of air ingoing into generator (aircooler, airheater, separator, filters) shall clean it from moisture, particles and oil and maintain specification temperature.

**9.16.12.6** The nitrogen receiver may be installed in the cargo area. The room where it is installed shall have exit to the open deck, the door is to open outwards.

**9.16.12.7** The oxygen-enriched air from the nitrogen generator is to extend outside rooms to the safe locations on the open deck outside of hazardous area, situated not within 3m of areas traversed by personnel and not within 6m of air intakes for machinery (engines and boilers) and all ventilation inlets. The nitrogen-product enriched gas from the protective devices of the nitrogen receiver is to extend outside rooms to the safe locations on the open deck, situated not within 3 m of areas traversed by personnel and not within 6m of air intakes for machinery (engines and boilers) and all ventilation inlets/outlets.

**9.16.12.8** On the outlet from the nitrogen generator there shall be installed devices which maintain permanent pressure of the inert gas.

**9.16.12.9** A shut-off valve shall be installed between the nitrogen generator and receiver.

**9.16.12.10** At least two non-return shut-off devices shall be fitted in the inert gas system. One of them shall have double blocking and blowoff arrangement, another — the local locking device. They shall be installed on the main in the cargo area before branch pipes specified in 9.16.6.2.

**9.16.12.11** There shall be mounted instruments for the permanent temperature and pressure indication: on the compressor delivery side; on the intake side of the nitrogen generator.

**9.16.12.12** There shall be mounted instruments for the permanent indication and registration during system operation:

.1 oxygen content in the inert gas at the output of nitrogen generator;

.2 pressure in the main before the retaning sealing valves required by 9.16.12.10.

**9.16.12.13** Instruments specified in 9.16.12.12 shall be fitted in the cargo control room, if any. If there is no cargo control room onboard the instruments shall be fitted in such a place where alarm may be received by the responsible crewmembers.

**9.16.12.14** Audible and visual alarm shall be provided to indicate:

.1 low air pressure in the compressor specified in 9.16.12.11;

.2 high air temperature specified in 9.16.12.11;

.3 high level of water in the separator specified in 9.16.12.5;

.4 breakdown of electrical heater (if fitted) specified in 9.16.12.5;

.5 high oxygen content specified in 9.16.12.3 and 9.16.12.12;

.6 stop of energy supply of instruments specified in 9.16.12.12;

.7 drop of gas pressure referred to in 9.16.12.12;

.8 increase of gas pressure referred to in 9.16.12.12.

**9.16.12.15** Automatic stop of compressor shall take place if alarm turns on as specified in 9.16.12.14.1 to 9.16.12.14.5 and 9.16.12.14.8. Automatic compressor protection shall comply with the requirements of 4.5, Part XV "Automation".

**9.16.12.16** Automatic locking of arrangements specified in 9.16.12.8 shall take place if power is disconnected from the compressor.

**9.16.12.17** Alarm required by 9.16.12.14 shall be installed in the engine room and cargo control room if such post is provided but in any case in such a room where alarm may be immediately received by the responsible crew member.

## 10 AIR, OVERFLOW AND SOUNDING PIPING

### 10.1 AIR PIPES

**10.1.1** Each tank intended for the storage of liquid and each filled cofferdam, as well as the ice boxes and sea chests, shall have air pipes.

The air pipes of ice boxes and sea chests shall have shut-off valves fitted directly on the them.

Air pipes of double-bottom tanks and of tanks adjoining the shell plating, as well as the air pipes of ice boxes and sea chests, shall be carried to above the bulkhead deck.

**10.1.2** The air pipes shall be fitted at the highest part of the tank and, as a rule, at a place that is at maximum distance from the filling pipe. The number and arrangement of the pipes shall be selected depending on the shape and size of the tank, and shall also preclude the formation of air pockets.

If the air pipes of fuel tanks are used as overflow (air/overflow) pipes, the requirements of 10.2.4 shall be complied with.

**10.1.3** The tanks extending from side to side of the ship shall be fitted with air pipes at either side. The air pipes shall not be used as filling pipes, except when the tank is fitted with more than one air pipe.

The air pipes of tanks carrying liquids of different kinds are not permitted to be laid into a common line.

**10.1.4** The height of the air pipes laid to the open deck measured from the deck to the point where water may have access below shall not be less than:

- 760 mm on the freeboard deck;
- 450 mm on superstructure decks.

Where such a height is an obstacle to operations on board a smaller height may be approved, provided the availability of closing arrangements or other circumstances make this substitution reasonable. Besides, in ships of restricted areas of navigation **R2**, **R2-RSN**, **R2-RSN(4,5)**, **R3-RSN** and **R3** the above pipe heights may be reduced on agreement with the Register. However, they shall not be less than **600** and **380** mm, accordingly.

Minimum wall thicknesses of the air pipes above deck shall be:

- 6 mm for  $d \leq 80$  mm;
- 8,5 mm for  $d \geq 165$  mm.

Intermediate sizes shall be determined by linear interpolation.

**10.1.5** The upper end of each air pipe shall be made as a bend, with its opening facing downwards or shall have another construction agreed upon with the Register.

**10.1.6** The open ends of air pipes of fuel oil and lubricating oil tanks shall be laid to positions on the open deck where the vapours issuing from the mentioned tanks cannot incur a fire hazard. Location and arrangement of air pipes for fuel oil service, settling and lubricating oil tanks shall be such that in the event of a broken air pipe this will not directly lead to the risk of ingress of sea water splashes or rainwater.

On oil tankers and combination carriers the open ends of air pipes of these tanks shall be in compliance with the requirements of 9.10.4.

The air pipes of fuel oil tanks with heating arrangements shall meet the requirements of 13.3.5.

**10.1.7** The air pipes of independent lubricating oil storage tanks, may terminate in spaces where the tanks are installed if precautions are taken that will preclude spillage of oil onto electrical equipment or heated surfaces in case the tank is overflowing.

**10.1.8** The outlets of air pipes situated on the open freeboard deck and superstructure deck of the first tier (refer to 1.2.5, Part III "Equipment, Arrangements and Outfit"), as well as the outlets of the air pipes on the decks of higher tiers within the area limited by the angle of flooding (refer to 1.2, Part IV "Stability") shall have permanently attached self-closing covers preventing the sea water from getting into the tanks, but allowing a free access of air and liquids. Closing devices shall meet the requirements of 4.4.

**10.1.9** The total cross-sectional area of the air pipes in tank filled by gravity shall not be less than the total sectional area of the filling pipes of these tanks.

**10.1.10** The total cross-sectional area of the air pipes of a tank filled by the ship's pumps or shore pumps, shall not be less than 1,25 times the cross-sectional area of the filling pipe of that tank.

The cross-sectional area of a common air pipe from several tanks shall be at least 1,25 times the area of the common filling pipeline of these tanks, the requirements of 10.2.3 being complied with.

**10.1.11** Where a tank filled by shipboard pumps or from shore pumps is fitted with an overflow pipe, the total cross-sectional area of the air pipes of the tank shall not be less than one-third of the filling pipe area.

Where the air pipes from several tanks fitted with overflow pipes are combined, the cross-sectional area of the common air pipe shall be at least one-third of the area of the common filling pipe of these tanks, the requirements of 10.2.3 being complied with.

**10.1.12** The air pipe nominal diameter shall be in any case at least 50 mm. This requirement does not apply to the air pipes indicated in 10.1.9.

**10.1.13** The arrangement of the air pipes shall preclude the formation of hydraulic seals in the pipes.

**10.1.14** The air pipes of fuel oil and lubricating oil tanks in way of accommodation and refrigerated cargo spaces shall not have detachable connections.

**10.1.15** Nameplates shall be affixed to the upper ends of all air pipes.

**10.1.16** The air pipes from crankcases of internal combustion engines shall comply with the requirements of 2.3.4, Part IX "Machinery" and 11.1.9 of the present Part.

**10.1.17** The air pipes from ballast compartments of floating docks shall be laid to a height not less than 300 mm above the margin line.

It is permitted to lay air pipes through the plating of wing walls.

Other requirements of the present Chapter are not applicable to the air pipes of the ballast compartments in floating docks.

**10.1.18** In passenger ships the open ends of air pipes terminating in the superstructure, shall be located at a height of 1 m above the waterline of the ship inclined up to 15° or the maximum angle of heel determined by calculations during intermediate flooding, whichever is the greater.

As an alternative to this air pipes of tanks, other than fuel oil and lubricating oil tanks, may be laid through the superstructure side.

**10.1.19** The open ends of the cargo tanks air pipes of oil recovery ships shall be laid to positions on the open deck where the issuing vapours cannot incur a fire hazard and shall be protected with flame-arresting fittings.

The clear area through the fitting shall not be less than open flow area of the air pipe.

**10.1.20** Test tank air pipes of cargo heating system condensate shall meet the requirements of 9.6.3.

**10.1.21** Upper ends of air pipes in expansion tanks within the ethylene glycol water solution systems shall be arranged to discharge to the open deck.

## 10.2 OVERFLOW PIPES

**10.2.1** Fuel oil tanks shall be provided with overflow pipes directing fuel to an overflow tank or storage tank, the capacity of which shall be increased by a value not less than the overflow tank capacity as stipulated by 10.3.1, and which shall be equipped in accordance with 10.3.2.

No overflow pipes may be fitted where the fuel oil system is so designed that no spilling overboard can occur during the loading and transfer of fuel. Besides fuel oil tanks, the overflow pipes shall be fitted on lubricating oil tanks specified in 14.4.4 and 20.4.3.

**10.2.2** The cross-sectional area of overflow pipes shall not be less than 1,25 of the filling pipe area. The cross-sectional area of the common overflow pipe of several tanks shall not be less than 1,25 of common filling pipe area.

**10.2.3** Where the overflow pipes from several integrated tanks located in different watertight compartments are laid to a common header or pipe, this header or pipe shall be located above the deepest damage waterline in ships having a subdivision mark in the class notation and above the deepest load waterline in other ships.

**10.2.4** Where air pipes are simultaneously used as overflow pipes, they shall not be connected to the air pipes of overflow tanks. In this case, the overflow pipes or a common overflow pipe shall be connected directly to the tank.

**10.2.5** Where a tank is used alternatively for the carriage of fuel oil, water ballast or liquid and dry cargoes, then in the case of a common overflow system the overflow pipes shall be so arranged as to preclude the possibility of liquid flowing from one tank into another and liquid cargo vapours entering tanks containing dry cargo. In such cases, subject to the Register approval the overflow pipes may be fitted with shut-off valves, provided such pipes are not used as air pipes.

**10.2.6** The overflow pipes of daily tanks and of fuel oil and lubricating oil settling tanks shall be laid to overflow tanks located below the tanks mentioned above.

**10.2.7** A sight glass shall be fitted on vertical overflow pipes at a readily visible and accessible location, or an alarm device shall be provided to give warning when the predetermined level is reached in the overflow tank (refer also to 10.3.2).

**10.2.8** Minimum overflow pipe bore shall be 50 mm.

**10.2.9** Overflow pipes shall be extended up to the bottom of the overflow tanks with a minimal clearance. The flow area in the clearance shall not be less than the sectional area of the overflow pipe.

## 10.3 OVERFLOW TANKS

**10.3.1** The capacity of an overflow fuel tank shall not be less than the maximum capacity of the fuelling and fuel transfer system within 10 min.

**10.3.2** An overflow tank shall be provided with audible and visual alarms operating whenever the tank filling reaches 75 per cent.

#### 10.4 SOUNDING ARRANGEMENTS

**10.4.1** Each tank intended for the storage of liquid, cofferdams and void spaces with bilge connections, as well as bilges and bilge wells in spaces, which are not accessible at all times, shall be provided with sounding pipes for level management generally extended to the open decks. In tanks, other sounding arrangements may be used, which design is approved by the Register.

Sounding pipes of independent tanks are not required to be laid to the open deck.

Upper ends of the sounding pipes of the fuel oil and lubricating oil tanks shall not be laid to the spaces which may present the risk of ignition of leakage from the sounding pipes. Laying of the sounding pipes of the fuel tanks to accommodation and service spaces is prohibited.

**10.4.2** Other oil-level gauges may be used instead of the sounding pipes, provided that they meet the following requirements:

**.1** in passenger ships the installation of such means shall not require penetration below the top of the tank and their failure or overfilling of the tanks shall not permit release of fuel;

**.2** in cargo ships the failure or overfilling of the above measuring instruments shall not permit release of fuel. The level indicators may be used with flat glass and self-closing cocks fitted between the level indicators and the fuel tanks. When the upper part of the indicator is connected to the top of the tank, the upper self-closing valve may be not installed. The use of glass pipes in the level indicators is not permitted.

**10.4.3** Where the double bottom forms bilges at the wings, or the ship has a flat bottom, the sounding pipes shall be installed at each side. These pipes shall be laid to positions above the bulkhead deck, which are at all times accessible for taking soundings. The sounding pipes shall be as straight as practicable and shall not interfere with taking soundings with a sounding rod.

**10.4.4** As a rule, the sounding pipes of fuel and oil tanks shall not terminate in machinery spaces. Where this requirement is impracticable, termination of sounding pipes in machinery spaces may be permitted on condition the following requirements are met:

**.1** in passenger ships, such pipes shall not require penetration below the top of the tank and their failure or overfilling of the tanks shall not permit release of fuel;

**.2** in cargo ships, the failure of such pipes or overfilling of the tank shall not permit release of fuel;

**.3** the sounding pipes shall terminate in locations remote from ignition hazards or they shall be screened;

**.4** terminations of sounding pipes shall be fitted with self-closing blanking devices and with a small-diameter self-closing control cock located below them;

**.5** structural measures shall be taken to prevent the spillage of fuel or oil on heated surfaces from the blanking device;

**.6** the pipes shall terminate at least 0,5 m above the plating.

**10.4.5** The sounding pipes of the double-bottom water storage tanks are permitted to be laid into spaces below the bulkhead deck that are located above them and are accessible at all times. Such pipes shall not be used as air pipes and shall be fitted with self-closing cocks.

**10.4.6** Provision shall be made under the open ends of the sounding pipes for welded striking plates or other strengthening to protect the bottom plating from damaging by a sounding rod.

In case of slotted sounding pipes with closed ends, adequately strong closing plugs shall be provided.

**10.4.7** The internal diameter of the sounding pipes shall be at least 32 mm and for ships of the restricted area of navigation **R3-RSN** it shall not be less than 25 mm. Sounding pipes, which pass through refrigerated cargo spaces, in which the temperature may be reduced to 0 °C and below, as well as sounding pipes of oil storage tanks in oil recovery ships shall have a internal diameter of not less than 50 mm.

**10.4.8** Nameplates shall be affixed to the upper ends of the sounding pipes.

**10.4.9** The ends of the sounding pipes laid to the exposed decks shall be fitted with tight plugs complying with the requirements of 2.1.8.

The use of closings of a different type shall be specially considered by the Register in each case.

If the sounding pipes project above the open deck, they shall be located at such positions where they cannot be damaged, otherwise they shall have appropriate guards.

**10.4.10** In floating docks the sounding pipes of ballast compartments shall be laid to the top deck of the side walls.

## 11 EXHAUST GAS SYSTEM

### 11.1 EXHAUST GAS PIPING

**11.1.1** The exhaust gas pipes shall, as a rule, be laid to the open decks.

**11.1.2** Where the exhaust gas pipes are laid through the shell plating in the vicinity of load waterline or below it, provision shall be made for arrangements precluding the possibility of sea water entering the engine.

**11.1.3** In oil tankers, oil recovery tankers, supply vessels, ships adapted for the carriage of explosive and fire hazardous cargoes and on ships servicing or towing the above-mentioned ships, the uptakes of boilers, exhaust pipes of main and auxiliary engines, incinerators shall be fitted with spark arresters of the construction approved by the Register.

**11.1.4** The exhaust gas pipes shall be laid at a distance not less than 450 mm from the fuel oil tanks.

**11.1.5** Each main engine shall have an individual exhaust gas pipe.

Where three or more auxiliary engines are fitted, their exhaust gas pipes may be connected to a common exhaust line provided that the engine with the greatest output has an autonomous exhaust pipe. Besides, the common exhaust line shall be fitted with reliable devices which will preclude:

gases of the common line entering the pipes of the engines not actually at work;

damage of any of the engines when started.

In ships of restricted areas of navigation **R2**, **R2-RSN**, **R2-RSN(4,5)**, **R3-RSN** and **R3** the exhaust gas pipes of the main and auxiliary engines may be permitted to connect to a common exhaust line, provided the foregoing precautions are taken. The exhaust gas pipes from DF-engines shall comply with the requirements of 9.5.2, Part IX "Machinery".

**11.1.6** The waste boilers and the composite waste heat/oil fired boilers, which by reason of structural features cannot be left without water while heated by exhaust gases, as well as the boilers mentioned in 3.2.16, Part X "Boilers, Heat Exchangers and Pressure Vessels" shall be provided with a by-pass line and dampers disconnecting the boilers from exhaust gas supply, when necessary.

**11.1.7** The uptakes of boilers incinerators and the exhaust gas pipes of internal combustion engines shall be thermally insulated by means of suitable insulating material, double walls or screens.

Where an insulating material is used for thermal insulation, the requirements of 2.1.1.5, Part VI "Fire Protection" shall be taken into consideration.

Double walls or screens are not required only in such positions where the possibility of their coming into contact with fuel or lubricating oil leaks is precluded.

**11.1.8** When the uptakes of main and auxiliary boilers are arranged to discharge into a common uptake, dampers are permitted, provided they have arrangements to be locked open. When required, manholes and vertical ladders shall be provided for inspection and cleaning of the uptakes and air ducts of boilers.

**11.1.9** In oil recovery ships, the outlets of exhaust gas piping of main and auxiliary engines, uptakes of boilers, incinerators and other equipment containing sources of ignition as well as air pipe vent openings of crankcases in internal combustion engines shall be located at least 6 m above the deepest waterline, but in any case outside the hazardous zones as defined in 19.2.3, Part XI "Electrical Equipment".

**11.1.10** The exhaust gas piping of main and auxiliary internal combustion engines shall be fitted with non-disconnectable draining devices to prevent the entry of water into the engine. The devices shall be readily accessible for maintenance and clearing and shall have a drain pipe bore not less than 25 mm.

**11.1.11** The exhaust gas pipes of engines shall be fitted with thermal compensators. The exhaust gas piping shall have, handholes and, when necessary, drain cocks.

**11.1.12** Where waste heat boilers are available on board, structural arrangements shall be provided to prevent the ingress of water into the exhaust gas duct of the internal combustion engines during washing. The draining pipes for the cleaning water shall be laid to the machinery space bilges and be provided with hydraulic seals.

### 11.2 SILENCERS AND SPARK ARRESTERS

**11.2.1** The silencers and spark arresters shall be so arranged as to permit cleaning and shall be fitted with appropriate handholes or drain cocks.

**11.2.2** Where spark arresters of the wet type are used, the requirements of 11.1.12 shall be met.

### 11.3 SYSTEMS FOR REDUCING NO<sub>x</sub> EMISSIONS

**11.3.1** The present requirements shall apply when Selective Catalyst Reduction (SCR) is used on board.

SCR requires the use of a reductant which may be a urea/water solution, aqueous ammonia or even anhydrous ammonia.

The efficiency in the plant operation shall be measured along with the engines as part of the ship's propulsion plant.

**11.3.2** Where urea based ammonia (e.g. 40 %/60 % urea/water solution) is introduced as a reductant, the following requirements shall be complied with:

**.1** where aqueous urea solution based ammonia is introduced, the storage tank shall be arranged so that any leakage will be contained and prevented from making contact with heated surfaces. All pipes or other tank penetrations shall be provided with manual closing valves attached immediately to the tank.

**.2** storage tank may be located both on exposed deck areas and in closed spaces including the engine room;

**.3** to ensure that the contents of the aqueous urea tank are maintained to avoid any impairment of the urea solution during storage, the storage tank shall be protected from excessively high or low temperatures considering concentration of the solution.

Heating and/or cooling systems shall be fitted, if necessary.

**.4** if a urea storage tank is installed in a closed space, the area shall be served by an independent mechanical supply and exhaust ventilation system providing at least 6 air changes per hour. The ventilation system shall be maintained in operation continuously and capable of being controlled from outside the compartment. If the ventilation stops, an audible and visual alarm shall be provided outside the compartment adjacent to each point of entry to the dangerous zone and inside the compartment, together with a warning notice requiring the use of such ventilation.

**.5** each urea storage tank shall be provided with temperature and level monitoring arrangements. High and low level alarms together with high and low temperature alarms shall also be provided

**.6** where urea based ammonia solution is stored in integral tanks, the following shall be considered during the design and construction:

**.6.1** these tanks may be designed and constructed as integral part of the hull, (e.g. double bottom, wing tank).

**.6.2** these tanks shall be coated with appropriate anti-corrosion coating and shall not be located in closed proximity of fuel oil or fresh water tanks;

**.6.3** these tanks shall be designed and constructed in compliance with the structural requirements applicable to hull and primary support members for a deep tank construction;

**.6.4** these tanks shall be fitted with but not limited to level gauge, temperature gauge, high temperature alarm, low level alarm, etc.;

**.6.5** these tanks shall be included in the ship's stability calculation.

**.7** reductant piping and venting systems shall be independent of other ship service piping. Reductant piping systems shall not be located in accommodation, service spaces, or control stations. The vent pipes of the storage tank shall terminate in a safe location on the weather deck and the tank venting system shall be arranged to prevent entrance of water into the urea tank;

**.8** reductant related piping systems, tanks, and other components which may come into contact with the reductant solution shall be of a suitable grade of non-combustible compatible material established to be suitable for the application;

**.9** for the protection of crew members, the ship shall have on board suitable personnel protective equipment. Eyewash and safety showers shall be provided, the location and number of which shall be derived from the detailed installation arrangements.

**.10** urea storage tanks shall be arranged so that they can be emptied of urea, purged and vented.

**11.3.3** Reductants using aqueous ammonia (28 % or less concentration of ammonia).

**11.3.3.1** Aqueous ammonia shall not be used as a reductant in a SCR except where it can be demonstrated that it is not practicable to use a urea based reductant. Where an application is made to use aqueous ammonia as the reductant then the arrangements for its loading, carriage and use shall be derived from a risk based analysis.

**11.3.4** Reductants using anhydrous ammonia (99.5 % or greater concentration of ammonia by weight)

**11.3.4.1** Anhydrous ammonia shall not be used as a reductant in a SCR except where it can be demonstrated that it is not practicable to use a urea based reductant and where the Flag State MA agrees to its use. Where it is not practicable to use a urea reductant then it is also to be demonstrated that it is not practicable to use aqueous ammonia. Where an application is made to use anhydrous ammonia as the reductant then the arrangements for its loading, carriage and use shall be derived from a risk based analysis.

## 12 VENTILATION SYSTEM

### 12.1 GENERAL REQUIREMENTS FOR VENTILATION SYSTEMS

**12.1.1** Generally, ventilation ducts shall not be laid through watertight bulkheads below the bulkhead deck. Where it is not practicable to avoid laying ventilation ducts through watertight bulkheads below the bulkhead deck, means of closure shall be provided at the penetrations ensuring watertightness and strength equal to that of local ship's structures and operated from a position above the bulkhead deck. Where ventilation ducts are laid through more than one watertight bulkhead, the means of closure of such openings shall be operated by power and be capable of being closed from the main machinery control room situated above the bulkhead deck.

**12.1.2** Where trunkways and vertical ducts of the ventilation system pass through watertight decks, they shall be watertight and equivalent in strength to adjacent hull structures within a single watertight compartment below the bulkhead deck.

**12.1.3** Ventilation ducts shall be adequately protected against corrosion or constructed of corrosion-resistant materials.

**12.1.4** Ventilation ducts for removal of explosion and fire-dangerous vapours and gases shall be gas-tight and shall not communicate with the ducts of other spaces.

**12.1.5** Ventilation ducts laid to cargo spaces, machinery spaces and other spaces fitted with smothering facilities shall have closures complying with 3.1.2.3, Part VI "Fire Protection".

**12.1.6** In places of possible sweating the ventilation ducts shall be properly insulated. Drain plugs shall be provided for the portions of ducts where water is likely to accumulate.

**12.1.7** The inlets and outlets of the ventilation systems shall be provided with closing appliances fitted with drives for closing them from positions outside these spaces. The means of closing shall be easily accessible as well as prominently and permanently marked and shall indicate whether the shutoff is open or closed.

The ventilator heads of supply ducts and the air inlets of ventilation systems shall be so located that the risk of drawing in air contaminated by gas, oil vapours, etc., is minimized, and admission of sea water into the ventilation ducts is precluded.

In icebreakers and ice class ships with ice strengthening precautions shall be taken to prevent admission of snow into the ventilation ducts. It is recommended to arrange the air intakes on both sides of the ship and to provide for heating arrangements.

**12.1.8** The ventilator coamings shall have a height in accordance with 7.8, Part III "Equipment, Arrangements and Outfit".

**12.1.9** The arrangement of ventilator heads in cargo spaces, special category spaces, open and closed spaces of ro-ro ships shall comply with the requirements of 2.1.4.7, Part VI "Fire Protection".

**12.1.10** Access routes to the controls for closure of the ventilation system, mentioned in 12.1.5 shall permit a rapid shutdown without regard to weather and sea conditions. For this routes:

- .1 are clearly marked and at least 600 mm clear width;
- .2 are provided with a single handrail or wire rope lifeline not less than 10 mm in diameter, supported by stanchions not more than 10 m apart in way of any route which involves traversing a deck exposed to weather; and

.3 are fitted with appropriate means of access (such as ladders or steps) to the closing devices of ventilators located in high positions (i.e. 1,8 m and above).

Alternatively, remote closing and position indicator arrangements from the bridge or a fire control station for those ventilator closures are acceptable.

**12.1.11** Ventilation ducts, including single and double wall ducts, shall be of steel or equivalent material except flexible elements of short length not exceeding 600 mm used for connecting fans to the ducting in air-conditioning rooms. Unless expressly provided otherwise in 12.1.21, any other material used in the construction of ducts, including insulation, shall also be non-combustible. However, short ducts, not generally exceeding 2 m in length and with a free cross-sectional area not exceeding 0,02 m<sup>2</sup>, need not be of steel or equivalent material, subject to the following conditions:

.1 the ducts shall be made of non-combustible material, which may be faced internally and externally with membranes having low flame-spread characteristics and, in each case, a calorific value not exceeding 45 MJ/m<sup>2</sup> of their surface area for the thickness used;

.2 the ducts are only used at the end of the ventilation device; and

.3 the ducts are not situated less than 600 mm, measured along the duct, from an opening in an "A" or "B" class division, including continuous "B" class ceiling;

.4 flexible components of combustible material with length not exceeding 600 mm may be used for connection of fans to the ducting in air conditioning room.

**12.1.12** Ducts passing through "A" class divisions shall meet the following requirements:

.1 where a thin plated duct with a free cross sectional area equal to, or less than,  $0,02 \text{ m}^2$  passes through "A" class divisions, the opening shall be fitted with a steel sheet sleeve having a thickness of at least 3 mm and a length of at least 200 mm, divided preferably into 100 mm on each side of a bulkhead or, in the case of a deck, wholly laid on the lower side of the decks penetrated;

.2 where ventilation ducts with a free cross-sectional area exceeding  $0,02 \text{ m}^2$ , but not more than  $0,075 \text{ m}^2$ , pass through "A" class divisions, the openings shall be lined with steel sheet sleeves. The ducts and sleeves shall have a thickness of at least 3 mm and a length of at least 900 mm. When passing through bulkheads, this length shall be divided preferably into 450 mm on each side of the bulkhead. These ducts, or sleeves lining such ducts, shall be provided with fire insulation. The insulation shall have at least the same fire integrity as the division through which the duct passes; and

.3 automatic fire dampers shall be fitted in all ducts with a free cross-sectional area exceeding  $0,075 \text{ m}^2$  that pass through "A" class divisions. Each damper shall be fitted close to the division penetrated and the duct between the damper and the division penetrated shall be constructed of steel in accordance with paragraphs 7.2.4.2.1 and 7.2.4.2.2. The fire damper shall operate automatically, but shall also be capable of being closed manually from both sides of the division. The damper shall be fitted with a visible indicator which shows the operating position of the damper. Fire dampers are not required, however, where ducts pass through spaces surrounded by "A" class divisions, without serving those spaces, provided those ducts have the same fire integrity as the divisions which they penetrate. A duct of cross-sectional area exceeding  $0,075 \text{ m}^2$  shall not be divided into smaller ducts at the penetration of an "A" class division and then recombined into the original duct once through the division to avoid installing the damper required by this provision.

**12.1.13** Ventilation ducts with a free cross-sectional area exceeding  $0,02 \text{ m}^2$  passing through "B" class bulkheads shall be lined with steel sheet sleeves of 900 mm in length, divided preferably into 450 mm on each side of the bulkheads unless the duct is of steel for this length.

**12.1.14** Ducts provided for the ventilation of machinery spaces of category A, galleys, vehicle spaces, ro-ro spaces or special category spaces shall not pass through accommodation spaces, service spaces, or control stations unless they comply with paragraph 12.1.15 or 12.1.16. Ducts provided for the ventilation of accommodation spaces, service spaces or control stations shall not pass through machinery spaces of category A, galleys, vehicle spaces, ro-ro

spaces or special category spaces unless they comply with paragraph 12.1.15 or 12.1.16.

**12.1.15** According to 12.1.14 ducts shall be:

.1 constructed of steel having a thickness of at least 3 mm for ducts with a free cross-sectional area of less than  $0,075 \text{ m}^2$ , at least 4 mm for ducts with a free cross-sectional area of between  $0,075 \text{ m}^2$  and  $0,45 \text{ m}^2$ , and at least 5 mm for ducts with a free cross-sectional area of over  $0,45 \text{ m}^2$ ;

.2 suitably supported and stiffened;

.3 fitted with automatic fire dampers close to the boundaries penetrated; and

.4 insulated to "A-60" class standard from the boundaries of the spaces they serve to a point at least 5 m beyond each fire damper.

**12.1.16** According to 12.1.14 ducts as alternative to 12.1.15 shall be:

.1 constructed of steel in accordance with 12.1.15.1 and 12.1.15.2; and

.2 insulated to "A-60" class standard throughout the spaces (refer to 12.1.14) they pass, except for ducts that pass through spaces of category (9) or (10) as specified in 2.2.1.3, Part VI "Fire Protection".

**12.1.17** When the ventilation duct specified in 12.1.16.2 or 12.1.15.4 is contiguous to accommodation or service spaces, fire insulation of the duct shall comply with Figs 12.1.17-1 to 12.1.17-4.

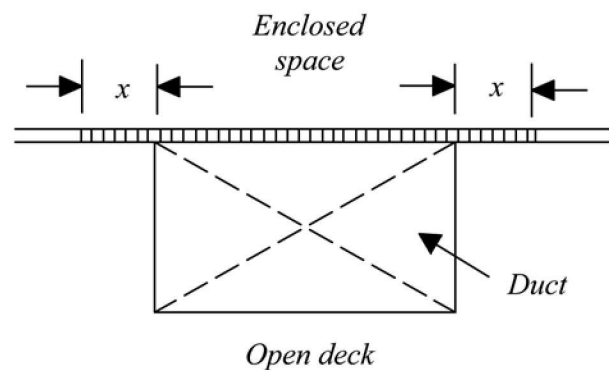

Fig. 12.1.17-1

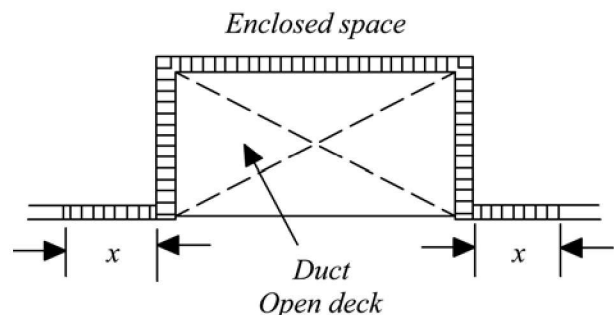

Fig. 12.1.17-2

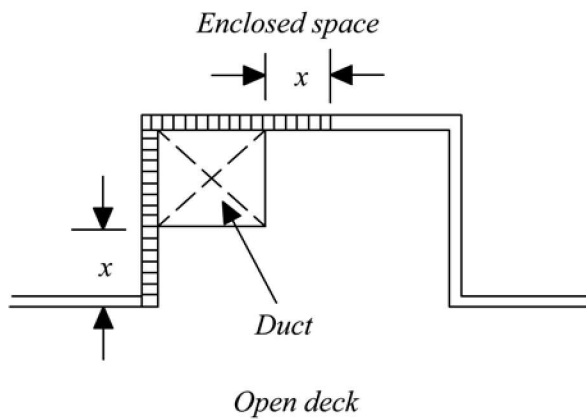

Fig. 12.1.17-3

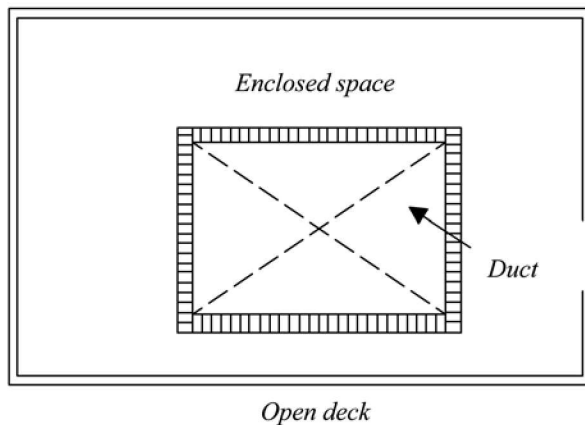
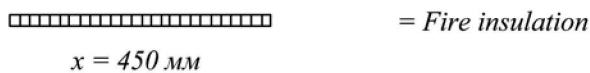

Fig. 12.1.17-4



**12.1.18** All fire dampers shall be capable of manual operation. The dampers shall have a direct mechanical means of release or, alternatively, be closed by electrical, hydraulic, or pneumatic operation. All dampers shall be manually operable from both sides of the division. Automatic fire dampers, including those capable of remote operation, shall have a failsafe mechanism that will close the damper in a fire even upon loss of electrical power or hydraulic or pneumatic pressure loss. Remotely operated fire dampers shall be capable of being reopened manually at the damper. Fire dampers shall be easily accessible. Where they are placed behind ceilings or linings, these ceilings or linings shall be provided with an inspection hatch on which the identification number of the fire damper is marked. The fire damper identification number shall also be marked on any remote controls provided.

**12.1.19** The following arrangements shall be tested in accordance with the Fire Test Procedures Code (FTP Code):

.1 fire dampers, except for specified in 12.2.4 and 12.3.6; and

.2 duct penetrations through "A" class divisions. However, the test is not required where steel sleeves are directly joined to ventilation ducts by means of riveted or screwed connections or by welding.

**12.1.20** Fire dampers fitted on the ventilation ducts from galley ranges in compliance with 12.2.5 and 12.3.6 do not need to pass the test according to FTP Code, but shall be of steel and capable of stopping the draught, if necessary. The requirements to "A" class divisions apply only to the part of the duct outside the galley.

**12.1.21** Combustible gaskets in flanged ventilation duct connections are not permitted within 600 mm of openings in "A" or "B" class divisions and in ducts required to be of "A" class construction.

**12.2 VENTILATION SYSTEMS OF CARGO SHIPS OF 500 GROSS TONNAGE AND UPWARDS, OIL TANKERS AND COMBINATION CARRIERS CARRYING PETROLEUM PRODUCTS WITH FLASH POINT 60 °C AND MORE, PASSENGER SHIPS CARRYING NO MORE THAN 36 PASSENGERS, SPECIAL PURPOSE SHIPS CARRYING NO MORE THAN 240 PERSONS AND BERTH-CONNECTED SHIPS**

**12.2.1** Ventilation system of accommodation and service spaces as well as control stations shall comply with the requirements of this Chapter and ensure that in all conditions of the ship's service there is an adequate supply of fresh air necessary for the safety and convenience of the operating personnel and reliable operation of the installed equipment.

**12.2.2** The ventilation systems for machinery spaces of category A, vehicle spaces, ro-ro spaces, galleys, special category spaces and cargo spaces shall, in general, be separated from each other and from the ventilation systems serving other spaces. However, the galley ventilation systems on cargo ships of less than 4,000 gross tonnage and in passenger ships carrying not more than 36 passengers need not be completely separated from other ventilation systems, but may be served by separate ducts from a ventilation unit serving other spaces. In such a case, an automatic fire damper shall be fitted in the galley ventilation duct near the ventilation unit.

**12.2.3** All necessary measures shall be taken for permanent ventilation of the control stations outside the machinery spaces, to ensure visibility and absence of smoke to the extent required for normal operation of the equipment in control stations and working of the attending personnel.

For the ventilation of these control stations two alternative and separate means of air supply shall be provided. The air supply ducts shall be fitted with fire or smoke dampers capable of being easily closed from within the control station so that, in the event of fire, smoke is kept from penetrating into the spaces.

These requirements need not be applied to the control stations situated on the open deck, to which they have a direct exit or where there are equally effective local closures of the control stations.

**12.2.4** Galley ventilation systems shall be separate from the ventilation systems serving other spaces.

The exhaust ducts from galley ranges shall be constructed of "A" class divisions where they pass through accommodation spaces or spaces containing combustible materials.

Each galley ventilation duct passing through accommodation spaces or other spaces containing combustible materials shall be fitted with:

- a grease trap readily removable for cleaning;
- a fire damper located in the lower end of the duct and, in addition, a fire damper located in the upper end of the duct;

- fixed means for extinguishing fire within the duct; arrangements, operable from within the galley, for shutting off the exhaust fans (refer also to 5.8.2, Part XI "Electrical Equipment").

**12.2.5** Where in passenger ships it is necessary that a ventilation duct passes through a division of the main vertical fire zone, a failsafe automatic closing fire damper shall be fitted adjacent to the division. The damper shall be also capable of being manually closed from each side of the division. As for the types of manual closing, refer to 12.2.3.2. The position for operating the damper shall be readily accessible and be marked in red light-reflecting colour. The duct between the division and damper shall be made of steel or other equivalent material and, bulkhead, shall be provided with insulation corresponding to the degree of fire integrity of the division. At least at one side of the bulkhead the damper shall be fitted with a readily visible indicator showing whether the damper is open.

**12.2.6** Provision shall be made for closing the inlets and outlets of all ventilation systems from outside the ventilated spaces. Manual closing arrangements shall be readily accessible and have indelible, readily visible marking, which shows whether the duct is open or closed.

**12.2.7** The ventilation ducts and their passages through "A" or "B" class divisions in ships of less than 500 gross tonnage shall, generally, be constructed in compliance with the requirements of the Chapter.

**12.2.8** Power ventilation of accommodation spaces, service spaces, cargo spaces, control stations

and machinery spaces shall be capable of being stopped from an easily accessible position outside the space being served. This position shall not be readily cut off in the event of a fire in the spaces served. However, it is not required for the ventilation fans and air-conditioners intended for air recirculation inside these spaces without air intake, for which only the local control may be provided. The ventilation fans servicing power ventilation systems shall be switched off in compliance with the requirements of 5.8.1 to 5.8.3, Part XI "Electrical Equipment".

### 12.3 VENTILATION SYSTEMS OF PASSENGER SHIPS CARRYING MORE THAN 36 PASSENGERS AND SPECIAL PURPOSE SHIPS CARRYING MORE THAN 240 PERSONS

**12.3.1** The ventilation systems of accommodation spaces, service spaces and control stations shall comply with the requirements of 12.2, besides meeting the requirements of the Chapter.

**12.3.2** In general, the ventilation fans and ducts shall be disposed within the main vertical fire zone, which they serve.

**12.3.3** A duct, irrespective of its cross-section, serving more than one 'tween-deck accommodation space, service space or control station, shall be fitted, near the penetration of each deck of such spaces, with an automatic smoke damper that shall also be capable of being closed manually from the protected deck above the damper.

Where a fan serves more than one 'tween-deck space through separate ducts within a main vertical zone, each dedicated to a single 'tween-deck space, each duct shall be provided with a manually operated smoke damper fitted close to the fan. If necessary, the vertical ducts shall be insulated providing fire integrity as required by 2.2.1.3, Part VI "Fire Protection".

**12.3.4** Except in cargo spaces, ventilation ducts shall be constructed of the following materials:

- .1 ducts with a cross-sectional area more than 0,075 m<sup>2</sup> and all vertical ducts serving more than a single 'tween-deck space shall be constructed of steel or other equivalent material;

- .2 ducts with a cross-sectional area less than 0,075 m<sup>2</sup> other than the vertical ducts mentioned in 12.3.4.1 shall be constructed of steel or equivalent material; where such ducts penetrate "A" or "B" class divisions, due regard shall be given to ensuring the fire integrity of the divisions;

- .3 short lengths of ducts not, in general, exceeding 0,02 m<sup>2</sup> in sectional area nor 2 m in length — of materials mentioned in 12.2.2.

**12.3.5** Ventilation systems of stairway enclosures shall be independent of other systems.

**12.3.6** Exhaust ducts from galley ranges, in which grease or fat is likely to accumulate, shall meet the requirements of 12.2.4 and shall be fitted with:

**.1** a grease trap readily removable for cleaning unless an alternative approved by the Register grease removal system is fitted;

**.2** a fire damper located in the lower end of the duct, which is automatically and remotely operated, and in addition a remotely operated fire damper located in the upper end of the duct (the lower end of the duct means position where the duct is connected to exhaust hood at the galley range; the upper end of the duct means position where the duct is closed as it leaves the galley);

**.3** fixed means for fire extinguishing within the duct;

**.4** remote control arrangements for shutting off the exhaust fans and supply fans, for operating the fire dampers mentioned in 12.3.6.2 and for operating the fire-extinguishing system, which shall be placed in a position close to the entrance to the galley. Where a multi-branch system is installed, means shall be provided to close all branches exhausting through the same main duct before an extinguishing medium is released into the system;

**.5** hatches for inspection and cleaning arranged close to the fire dampers. One hatch shall be located nearby the exhaust fan, other hatches — in the lower part of ducts;

**.6** exhaust ducts from ranges for cooking equipment installed on open decks shall conform to 12.3.6.1-5, as applicable, when passing through accommodation spaces or spaces containing combustible materials.

**12.3.7** Where public spaces span three or more decks and contain combustibles such as furniture and enclosed spaces such as shops, bars and restaurants, such spaces shall be equipped with a ventilation activated by a smoke detection system and capable to ventilate the entire volume during not more than 10 min. Provision shall be made for manual control of the fans.

**12.3.8** Power ventilation, except cargo holds and machinery space ventilation, shall be fitted with controls so grouped that all fans may be stopped from either of two separate positions which shall be situated as far apart as practicable. However, it is not required for the ventilators and conditioners intended for air recirculation inside these spaces without air intake, for which only the local control may be provided.

Fans serving power ventilation systems to cargo spaces shall be capable of being stopped from a safe position outside such spaces.

Power ventilation of machinery spaces shall be fitted with controls so grouped that they may be

controlled from two separate positions one of them to be located outside the machinery space.

**12.3.9** Ventilation systems of passenger ships shall comply with the requirement of 2.2.8.6, Part VI "Fire Protection".

The ventilation systems of safety zones of passenger ships having length, as defined in 1.2.1 of the Load Line Rules for Sea-Going Ships, of 120 m or more or having three or more main vertical zones, shall additionally comply with the requirements of 2.2.6.10, Part VI "Fire Protection".

The ventilation system serving safety centers may be derived from the ventilation system serving the navigation bridge, unless located in an adjacent main vertical zone.

**12.3.10** Exhaust ducts from ranges for cooking equipment installed on open decks shall comply with the requirements of 12.3.6, as applicable, when passing through accommodation spaces or spaces containing combustible materials.

**12.3.11** Exhaust ducts from main laundries shall be fitted with:

**.1** filters readily removable for cleaning purposes;

**.2** a fire damper located in the lower end of the duct which is automatically and remotely operated;

**.3** remote-control arrangements for shutting off the exhaust fans and supply fans from within the space and for operating the fire damper mentioned in 12.3.11.2;

**.4** suitably located hatches for inspection and cleaning.

#### **12.4 VENTILATION SYSTEMS OF OIL TANKERS AND COMBINATION CARRIERS CARRYING CRUDE OIL AND PETROLEUM PRODUCTS WITH FLASH POINT 60 °C AND BELOW**

**12.4.1** In addition to requirements of 12.1, 12.2, 12.6 and 12.9, the ventilation systems shall comply with the requirements of the Chapter.

**12.4.2** The ventilation inlets of accommodation spaces, service spaces and control stations shall be located on the aft transverse bulkhead not facing cargo tanks, or on the side of the superstructure or deckhouse at a distance equal, at least, to 4 per cent of the ship's length, but not less than 3 m from the end of the superstructure or deckhouse facing cargo tanks. This distance, however, need not exceed 5 m.

The inlets and outlets of ventilation ducts for machinery spaces shall be situated as far aft as practicable. Special consideration shall be given to location of these vents in oil tankers equipped to load and discharge at the stern.

**12.4.3** Cargo pump rooms shall be mechanically ventilated and discharges from the exhaust fans shall

be laid to a safe place on the open deck. The ventilation of these rooms shall have sufficient capacity to minimize the possibility of accumulation of flammable vapours. The number of air changes shall be at least 20 per hour, based upon the gross volume of the space. The air ducts shall be arranged so that all of the space is effectively ventilated. The suction ventilation shall be of mechanical type using fans of the non-sparking type. Input ventilation may be self-ventilation. Lighting shall be interlocked with ventilation in accordance with 19.2.4.4, Part XI "Electrical Equipment".

**12.4.4** The inlets of exhaust ducts shall be situated so as to provide extraction of air from below the floor plates. The bottom framing, as well as the floor plates and gratings of the pump room shall be so constructed as not to impede the free flow of air to the inlets of the exhaust ducts.

Outside the pump room these ducts shall be gastight and, generally, shall not communicate with the ducts of other spaces.

The pump rooms shall have also an emergency ventilation operating in the event of lower inlets being flooded. For this purpose an emergency intake about 2 m above the lower grating shall be provided on the exhaust duct. This intake shall have a damper capable of being operated from the main deck and lower grating level. The damper may be omitted if the areas of the inlets are chosen such that at least 20 air changes per hour will be ensured through the lower inlets, and at least 15 air changes per hour through the upper inlets in case of the lower inlets being flooded.

Where the ventilation system of the pump room is used for ventilating the cargo line and the communicating cargo tanks, duplicate shut-off fittings shall be provided at the connections of the ventilation duct to the cargo line.

**12.4.5** The construction of the ventilation fans in cargo pump rooms shall comply with the requirements of 5.3, Part IX "Machinery" and the location of their driving motors shall meet the requirements of 4.2.5, Part VII "Machinery Installations".

**12.4.6** The outlets of exhaust ducts for cargo pump rooms shall not be less than 2 m remote from any opening leading into ship spaces, which may contain a source capable of ignition oil vapours, and shall be so located that no contamination of air entering the inlets of ventilation systems will occur.

The outlets of exhaust ducts shall be fitted with flame-arresting fittings.

The inlets of ventilation ducts shall be protected in accordance with 5.3.3.2 of Part IX "Machinery".

The air intakes shall be situated at least 2,4 m above the cargo deck and at least 5,0 m from any

openings of the cargo tanks and outlets of the pressure/relief valves, and at least 10 m from the outlets of vent pipes that expel freely the vapour/air mixture or are fitted with high-speed devices.

**12.4.7** In combination carriers, all cargo spaces and all enclosed spaces adjacent to the cargo spaces shall be capable of being mechanically ventilated. This ventilation may be provided by portable fans.

**12.4.8** On oil tankers:

.1 double hull and double bottom spaces shall be fitted with suitable connections for the supply of air;

.2 if an inert gas system is required, spaces mentioned in 12.4.8.1 shall be connected to the fixed inert gas distribution systems; provision shall be also made for arrangements to prevent leakage of the hydrocarbon gas from the cargo tanks into such spaces through the inert gas distribution system.

Where these spaces are not connected constantly to the inert gas distribution sources arrangements shall be provided to ensure such connection.

## 12.5 VENTILATION OF MACHINERY SPACES AND TUNNELS

**12.5.1** The ventilation of machinery spaces of category A shall be such as to ensure that when the machinery and boilers therein are operating at full load in all service conditions including heavy weather, a supply of air is maintained to the spaces sufficient for the safety and comfort of the personnel and the operation of machinery.

The ventilation shall ensure removal of gases heavier than air from the lower zones of those spaces, from below floor plates, from where fuel system equipment, settling and supply tanks are installed.

Any other machinery spaces shall be adequately ventilated appropriate to the purpose of the machinery space.

The requirements for the ventilation of refrigerating machinery spaces are given in 3.1.6 and 3.1.7, Part XII "Refrigerating Plants".

**12.5.2** Shaft tunnels shall be properly ventilated. The pipe tunnels laid in the double bottom shall have mechanical exhaust ventilation.

**12.5.3** In the space containing emergency diesel-generator (automatically started), provision shall be made for an automatic arrangement to ensure an air supply sufficient for the emergency diesel-generator to run under full load in any service conditions when the space is closed.

**12.5.4** In spaces mentioned under 4.2.7, Part VII "Machinery Installations", independent mechanical exhaust ventilation or a ventilation device separable from the machinery space ventilation shall be

installed. The construction of fans shall comply with the requirements of 5.3, Part IX "Machinery".

**12.5.5** Where a ventilation room serves only such an adjacent machinery space and there is no fire division between the ventilation room and the machinery space, the means for closing the ventilation duct or ducts serving the machinery space shall be located outside of the ventilation room and machinery space.

Where a ventilation room serves such a machinery space as well as other spaces and is separated from the machinery space by a "A-0" class division, including penetrations, the means for closing the ventilation duct or ducts for the machinery space can be located in the ventilation room.

**12.5.6** Emergency generator rooms are provided with ventilation openings for the admission of combustion air to engines and the removal of heat. These openings are usually provided with louvers which can be closed (when fire breaks out in emergency generator rooms). The louvers may be hand-operated or power-operated. Alternatively, the louvers may be of fixed type with a closing door which may be hand-operated or automatic.

The following requirements apply to ventilation louvers for emergency generator rooms and to closing appliances where fitted to ventilators serving emergency generator rooms:

**.1** ventilation louvers and closing appliances may either be hand-operated or power-operated (hydraulic / pneumatic / electric) and are to be operable under a fire condition;

**.2** hand-operated ventilation louvers and closing appliances shall be kept open during normal operation of the ship. Corresponding instruction plates shall be provided at the location where hand-operation is provided;

**.3** power-operated ventilation louvers and closing appliances shall be of a fail-to-open type. Closed ventilation louvers and closing appliances are acceptable during normal operation of the ship.

Power-operated ventilation louvers and closing appliances shall open automatically whenever the emergency generator is starting / in operation;

**.4** It shall be possible to close ventilation openings by a manual operation from a clearly marked safe position outside the space where the closing operation can be easily confirmed. The louver status (open / closed) shall be indicated at this position. Such closing shall not be possible from any other remote position.

## **12.6 VENTILATION OF SPECIAL CATEGORY SPACES, CARGO SPACES INTENDED FOR THE CARRIAGE OF MOTOR VEHICLES WITH FUEL IN THEIR TANKS AND CLOSED RO-RO CARGO SPACES**

**2.6.1** These spaces shall have mechanical exhaust ventilation system independent from other ventilation systems, which shall function during the whole period the motor vehicles are carried in such spaces.

If individual spaces have effective closures, ventilation ducts shall be separate for each of them. The fans shall be operated from outside the ventilated spaces and to be capable of ensuring at least:

**.1** 10 air changes per hour:

in cargo spaces for the carriage of motor vehicles with fuel in their tanks in passenger ships carrying more than 36 passengers;

in special category spaces in all passenger ships;

in closed ro/ro cargo spaces with electrical equipment in accordance with 19.3.4, Part XI "Electrical Equipment" in all ships;

**.2** 6 air changes per hour in all other ships;

**.3** in cargo spaces for the carriage of motor vehicles, where an air quality control system is provided based on MSC.1/Circ.1515, the ventilation system may be operated at a decreased amount of ventilation. This relaxation does not apply to spaces to which at least ten air changes per hour is required by 19.3.4.1, of Part XI "Electrical Equipment".

**12.6.2** The ventilation shall be such as to provide even distribution of air supply and shall prevent formation of trapped zones.

**12.6.3** The ventilation system shall be equipped with devices indicating any loss or reduction of the ventilating capacity and operation of the fans. These devices shall be installed in the wheelhouse.

Instead of them, the following means may be provided:

**.1** visual signal indicating the operation of each fan;

**.2** interlock to permit the electric motor of the fan to start only if the ventilation duct is open;

**.3** audible signal for spontaneous stop of the electric motor.

**12.6.4** The construction of the fans shall comply with the requirements of 5.3, Part IX "Machinery".

**12.6.5** Arrangements shall be provided for effective closure of the ventilation system in case of fire and shall meet the requirements of 12.1.10.

**12.6.6** The ventilation ducts and their closures shall be made of steel.

**12.6.7** Ducts intended for ventilation of special-category spaces, which pass through other special-category spaces, shall be constructed of steel. Where such ventilation ducts pass through special-category spaces, which do not form part of the of the same main horizontal zone, the ducts shall be insulated to A-60 standard. Ventilation ducts shall not pass through machinery spaces unless they are constructed of "A-60" class divisions.

#### **12.7 VENTILATION OF CARGO SPACES ADAPTED FOR THE CARRIAGE OF DANGEROUS GOODS<sup>1</sup>**

**12.7.1** Closed cargo spaces in cases mentioned in 7.2.4, Part VI "Fire Protection" shall have mechanical exhaust ventilation, separate for each such space, sufficient to give at least 6 air changes per hour, based upon the volume of an empty hold.

Supply ventilation of these spaces may be natural.

On agreement with the Register, mechanical supply and natural exhaust ventilation systems are permissible.

The number of air changes may be reduced with regard to the method of transportation (refer to Note 1 to Table 7.2.4-1, Part VI "Fire Protection").

**12.7.2** For closed cargo spaces intended for the carriage of dangerous goods in bulk at least natural ventilation in accordance with 7.2.8.3, Part VI "Fire Protection" is required.

However, when conditions of carriage require a mechanical ventilation system, a stationary system may be dispensed with, provided that portable fans ensuring adequate effectiveness of the ventilation are used.

**12.7.3** The ventilation shall be such as to provide uniform change of air within the cargo space and to prevent formation of trapped zones.

The ventilation system shall be such that vapours of dangerous goods are removed from upper or lower part of the space, with regard to density of the vapours in relation to air.

**12.7.4** The construction of ventilation fans shall comply with the requirements of 5.3, Part IX "Machinery".

The electric motors of the fans shall be of flameproof design. It is not recommended to arrange them in way of gas exhaust.

The inlets and outlets of ventilation systems shall be protected by screens with mesh size of 13 × 13 mm.

**12.7.5** The ventilator heads of exhaust ducts from cargo spaces adopted for the carriage of dangerous

goods emitting readily flammable and toxic vapours or gases shall be so located that the issuing vapours or gases will not enter other ship spaces.

**12.7.6** Rooms containing bilge pumps servicing cargo spaces for carriage of dangerous goods shall be provided with separate artificial exhaust ventilation sufficient to give at least 6 air changes per hour.

**12.7.7** During carriage of goods capable of producing explosive mixtures with air, and goods susceptible to spontaneous ignition provision shall be made for two fixed or portable fans of flameproof design with a total capacity sufficient to provide 6 air changes per hour.

**12.7.8** Ventilation system of ships carrying packaged irradiated nuclear fuel, plutonium and high-level radioactive wastes (INF cargo, refer to 7.1.2, Part VI "Fire Protection") shall comply with the following requirements:

.1 provision shall be made for adequate ventilation or cooling of closed cargo spaces so that at any time the mean ambient temperature within these spaces does not exceed 55 °C;

.2 ventilation or cooling systems serving cargo spaces intended for carriages of INF cargo shall be independent from similar systems serving other spaces; and

.3 equipment indispensable for operation, such as fans, compressors, heat exchangers, cooling liquid supply systems shall be duplicated for each cargo space.

**12.7.9** The open top container holds shall be mechanically ventilated by means of special ducts from the lower parts of cargo holds. The ventilation capacity shall be at least 2 air changes per hour based on the empty hold volume below weather deck.

**12.7.10** If the International Maritime Solid Bulk Cargoes Code (IMSBC Code) requires continuous ventilation of holds for the carriage of dangerous goods, the inlet and outlet ventilation openings not requiring the means of closure according to the Load Line Rules for Sea-Going Ships shall be used only. Means of closure for ventilation openings as required for fire protection purposes under 12.1.6 shall be provided and the minimum height to ventilation openings allowed not to have means of closure shall be in accordance with 7.8.2, Part III "Equipment, Arrangements and Outfit".

**12.7.11** If enclosed spaces adjacent to cargo hold are not separated from cargo spaces by sealed cover then they are considered as part of the enclosed cargo hold and the ventilation requirements shall apply to the adjacent space as for the enclosed cargo space itself. Where the IMSBC Code requires 2 fans per each hold, a common ventilation system with 2 fans connected is acceptable.

<sup>1</sup>For "dangerous goods", refer to 7.1.2, Part VI "Fire Protection".

### 12.8 VENTILATION OF REFRIGERATED CARGO SPACES

**12.8.1** The requirements to the ventilation of refrigerated cargo spaces are set out in 3.3.5 to 3.3.8, Part XII "Refrigerating Plants".

### 12.9 VENTILATION OF FIRE EXTINGUISHING STATIONS

**12.9.1** The foam fire extinguishing and smothering stations, located below the upper deck or not accessible from the weather deck shall be equipped with efficient independent ventilation system with capacity sufficient to provide not less than 6 air changes per hour.

The carbon dioxide fire extinguishing stations shall be provided with an exhaust and supply ventilation independent from other ventilation systems. The inlets of exhaust ducts shall be located in lower part of the station.

**12.9.2** The high-expansion foam fire extinguishing stations shall be equipped with devices ensuring air supply in an amount sufficient for the operation of foam generators.

### 12.10 VENTILATION OF ACCUMULATOR BATTERY ROOMS AND BOXES

**12.10.1** The accumulator battery rooms and boxes shall be provided with independent ventilation system capable of removing air from upper part of the ventilated spaces.

The exhaust ducts shall be gastight.

**12.10.2** The inlet air shall be supplied into the lower part of the ventilated space.

**12.10.3** The outlets of ventilation ducts shall be so constructed as to preclude the admission of sea water, atmospheric precipitation and solids.

No flame-arresting fittings shall be installed.

The discharges of exhaust ducts shall be laid to places where the issuing gases do not present a fire hazard.

**12.10.4** The boxes of accumulator batteries having a charging capacity not over  $2,0 \times 10^2$  W may be ventilated through the openings in the lower and upper parts of the box to ensure removal of the gases.

**12.10.5** The rate of air flow  $Q$ , in  $\text{m}^3/\text{s}$ , for the ventilation of an accumulator battery room or box shall not be less than that determined by the formula

$$Q = 3,06 \cdot 10^{-5} I n \quad (12.10.5)$$

where  $I$  = maximum charging current during gas emission, but not less than 0,25 of maximum current of the charging device, A;  
 $n$  = number of battery cells.

**12.10.6** The cross-sectional area  $F$ , in  $\text{m}^2$ , of a duct, in case of natural ventilation of accumulator battery rooms and boxes, shall not be less than determined by the formula

$$F = 1,04 Q \quad (12.10.6)$$

where  $Q$  is the rate of air flow determined by Formula (12.10.5), but not less than  $0,004 \text{ m}^2$ .

**12.10.7** Natural ventilation of the spaces may be used in the following cases:

.1 the required amount of air, calculated by Formula (12.10.5), is less than  $2,36 \times 10^{-2} \text{ m}^3/\text{s}$ ;

.2 the angle of the duct deflection from the vertical is less than  $45^\circ$ ;

.3 the number of bends of the duct does not exceed 2;

.4 the length of the duct does not exceed 5 m;

.5 the operation of ventilation system does not depend on the direction of the wind;

.6 the cross-sectional area of the duct shall be taken not less than that determined by Formula (12.10.6).

**12.10.8** Where the rate of air flow determined by Formula (12.10.5) is  $2,36 \times 10^{-2} \text{ m}^3/\text{s}$  and over, the accumulator battery room shall be provided with mechanical exhaust ventilation.

**12.10.9** The internal surfaces of the exhaust ducts, as well as the ventilating fans shall be protected against the action of the electrolyte vapours.

**12.10.10** The motors of the ventilating fans shall not be arranged in way of gas exhaust.

The construction of the ventilating fans shall comply with the requirements of 5.3, Part IX "Machinery".

**12.10.11** Ventilation serving for battery rooms shall be equipped as follows:

.1 usually, open ends of ventilation ducts from battery rooms shall not have outlets directly to the open decks and they shall be fitted with means of closing. Closing devices shall be provided if it is required by the International Convention on Load Lines as well as 3.2.1 of Load Lines Rules for Sea-Going Ships or premises equipped with a fixed gas fire extinguishing system;

.2 where an open outlet of battery room ventilator is fitted with a closing device, then a warning notice stating, for example, "This closing device shall be kept open and only closed in the event of fire or other emergency — DO NOT CLOSE ! EXPLOSIVE GAS", shall be provided at the closing device to mitigate the possibility of inadvertent closing.

### 12.11 VENTILATION OF HANGARS FOR HELICOPTERS

**12.11.1** The hangars for helicopters and spaces where helicopter refueling and maintenance facilities are located shall comply with requirements of 6.5, Part XVII "Distinguishing Marks and Descriptive Notations in the Class Notation Specifying Structural and Operational Particulars of Ships".

### 12.12 VENTILATION OF SPACES IN OIL RECOVERY SHIPS

**12.12.1** Ventilation systems serving dangerous and safe spaces shall be independent of each other. Spaces in zones belonging to different classes as listed under 19.2.3, Part XI "Electrical Equipment" shall be served by different systems.

**12.12.2** Safe spaces and air locks shall be equipped with mechanical supply ventilation to ensure excessive pressure therein as compared to adjacent dangerous spaces.

**12.12.3** Provision shall be made for automatic switch on of ventilators and signalling for loss of excessive pressure in safe spaces and air locks. Alternatively, the following may be provided:

- .1 light signalling of each ventilator operation;
- .2 blocking to ensure the electric motor of the ventilator is switched on only when the vent duct cover is open;
- .3 sound signalling of spontaneous stop of electric motor of the ventilator.

**12.12.4** The suction of supply ventilation ducts shall be located outside dangerous spaces on open decks.

**12.12.5** Exhaust duct openings shall be fitted with flame aborting strainers.

**12.12.6** Dangerous spaces in Zone 1 shall be provided with mechanical exhaust ventilation to ensure

at least 20 air changes per hour. Application of ventilation systems for 10 air exchanges per hour is allowed, provided the system is fitted with automatic switching for 20 air changes per hour, when the gas concentration of  $(20 \pm 10)$  per cent of the lower limit of the explosive range is reached in the atmosphere of the space.

Dangerous spaces in Zone 2 shall be provided with ventilation to ensure at least 10 air changes per hour.

**12.12.7** In dangerous spaces, the exhaust ventilation ducts shall be gas-tight, rigid enough and shall not pass through safe spaces (except where the ducts of the pressure part of ventilation are laid through safe spaces in gas-tight tunnels).

**12.12.8** In spaces and air locks, the ventilation systems shall be equipped with instruments to monitor the operation of ventilators and other devices mentioned under 12.12.3 and 12.12.6.

### 12.13 VENTILATION OF SPACES INTENDED FOR INERT GAS EQUIPMENT

**12.13.1** In spaces intended for the inert gas equipment of cargo tanks including generators, scrubbers, ventilators and their valves, provision shall be made for artificial exhaust ventilation which shall ensure at least six air changes per hour as determined proceeding from the empty space volume.

Forced ventilation may be natural ventilation.

When the above equipment is installed in machinery spaces, the requirements of 12.5 shall be complied with.

**12.13.2** For ventilating spaces mentioned under 9.16.9.3, Part VI "Fire Protection", provision shall be made for artificial forced ventilation, which shall ensure the number of air changes not less than stipulated under 12.13.1.

## 13 FUEL OIL SYSTEM

### 13.1 PUMPS

**13.1.1** At least two pumps shall be provided for fuel transfer, one of which being a standby pump. Any suitable pump, including the fuel oil separator pump, may be used for standby purpose. Standby fuel pump should be started automatically regardless the automation class of the ship for any unattended engine rooms.

For cargo ships of less than 500 gross tonnage navigating in restricted areas **R2, R2-RSN, R2-RSN(4,5), R3-RSN** и **R3** резервный насос не требуется.

In ships with a daily consumption of fuel less than  $I_t$ , a hand pump is admissible.

**13.1.2** Where the fuel oil tanks, including the deep tanks, are used also for water ballast, provision shall be made for reliable arrangements disconnecting the ballast system from these tanks when carrying fuel oil and the fuel oil system, when containing water.

In addition, the requirements of the Guidelines on the Application of Provisions of the International Convention MARPOL 73/78 shall be complied with.

**13.1.3** The fuel oil and lubricating oil transfer pumps and the separator pumps, besides local hand control, shall be provided with stopping means operable from always accessible positions outside the space where the pumps are installed.

**13.1.4** Shut-off valves shall be fitted on the pressure side and suction side of fuel oil and lubricating oil pumps.

Devices for measuring fuel oil temperature are recommended to be provided on the suction pipes of the fuel oil pumps.

This requirement is mandatory for installations with fuel oil flash point of less than 60 °C.

**13.1.5** For ships intended to use Heavy Fuel Oil (HFO) or Marine Diesel Oil (MDO) in non-restricted areas and marine fuels with a sulphur content not exceeding 0,1 % m/m and minimum viscosity of 2 sSt in emission control areas, the following arrangements should be provided in addition to 13.1.1:

**.1** in non-restricted areas, ships provided with two fuel oil pumps that can each supply the fuel primarily used by the ship (i.e. HFO or MDO) in the required capacity for normal operation of the propulsion machinery.

**.2** in emission control areas one of the following requirements should be met:

fuel oil pumps as in 13.1.5.1, provided these are each suitable for marine fuels with a sulphur content not exceeding 0,1 % m/m and minimum viscosity of

2 sSt in the required capacity for normal operation of the propulsion machinery;

when the fuel oil pumps in 13.1.5.1 are suitable to operate on marine fuels with a sulphur content not exceeding 0,1 % m/m and minimum viscosity of 2 sSt, but one pump alone is not capable of delivering such fuel, then both pumps may operate in parallel. In this case, one additional (third) fuel oil pump shall be provided. The additional pump shall, when operating in parallel with one of the pumps in 13.1.5.1, be suitable for and capable of delivering marine fuels at the required capacity for normal operation of the propulsion machinery;

in addition to pumps as in 13.1.5.1, two separate fuel pumps shall be provided, each capable of and suitable for supplying marine fuels with a sulphur content not exceeding 0,1% m/m and minimum viscosity of 2 sSt at the required capacity for normal operation of propulsion machinery.

If a marine distillate grade fuel with a different maximum sulphur content is specified by regulation for the area of operation of the ship (e.g. ECA, specific port or local areas, etc.) then that maximum shall be applied.

Where electrical power is required for the operation of propulsion machinery, the requirements are also applicable for machinery for power generation when such machinery is supplied by common fuel supply pumps.

### 13.2 PIPING LAYING

**13.2.1** In general, the fuel oil pipeline shall have no communication with other piping systems. Where the fuel oil tanks are used also for water ballast, the requirements of 13.1.2 shall be complied with.

**13.2.2** Welded joints shall be generally applied for the assembly of piping for fuel oil with a flash point below 60 °C and for oil heated above 60 °C, whereas the number of detachable joints shall be reduced to a minimum. Such pipes containing oil under a pressure of 0,18 N/mm<sup>2</sup> and above shall not be placed in a concealed position, they shall be readily accessible and their locations shall be adequately illuminated.

**13.2.3** The fuel pipes shall not be laid above the internal combustion engines, turbines, exhaust gas pipes, steam pipes (except heating steam coils), steam boilers and boiler uptakes. In exceptional cases, it is allowed to lay the fuel pipes above the said equipment provided that in these positions the pipes have no detachable joints or are shielded and that in necessary places provision is made for trays prevent-

ing the spillage of fuel on the equipment or other sources of ignition.

**13.2.4** The fuel pipes which damage may cause fuel leakage from tanks, slop and supply service tanks of 500 l and more located above double bottom shall be fitted with a tap or valve installed directly on a tank which can be closed from a safe position outside such space if fire happens in a space where such tanks are located. In special cases when deep tanks are located in a propeller shaft tunnel, in pipe tunnel or any other similar space then the valves shall be located on deep tanks however there shall be an option to control the additional valve fitted on a pipeline or pipelines outside the tunnel or other similar space. Such a cock or valve may be fitted on straight branch pipes welded to the shell plating, provided they are rigid enough and have the minimum length. If such additional tank is fitted in the machinery space, it shall be controlled from a position outside such space. Remote control of the fuel tank for the emergency diesel generator shall be located in a separate space apart from the remote controls for other tank valves located in the machinery space.

**13.2.5** Where the fuel oil system is fitted with flow metering devices or similar metering instruments, they shall be provided with a by-pass line and relevant shut-off valves for performing the maintenance and repair including cleaning of the built-in filters without interrupting the operation of the internal combustion engines (boilers).

### 13.3 HEATING ARRANGEMENTS OF FUEL OIL

**13.3.1** For fuel oil heating the heat-carrying agents enumerated in 9.6.1 may be applied. In case of using electric heating appliances for fuel oil heating, the requirements of 15.3, Part XI "Electrical Equipment" shall be complied with.

**13.3.2** Heating coils and electric heating appliances shall be fitted as low as possible in the tanks.

**13.3.3** In daily service tanks and settling tanks, the suction ends of fuel pipes shall be so positioned above the heating coils and electric heating appliances that the latter remain submerged as far as practicable.

**13.3.4** When fuel oil and lubricating oil steam heaters or other heating medium heaters are used, except cases when the heated medium temperature does not reach a flash point, the system shall be fitted with an alarm on a high temperature or a flow drop in addition to the system for temperature monitoring.

**13.3.5** The maximum temperature of fuel oil heating in storage tanks shall be 15 °C below the fuel oil flash point.

Fuel oil in service tanks, settling tanks and any other tanks in the engine and boiler supply system may be heated above this limit, provided:

.1 the length of air pipes of these tanks or the use of cooling devices permits to lower the temperature of escaping vapours below 60 °C or the outlets of air pipes are situated at least 3 m away from ignition sources;

.2 non-intrinsically safe electrical equipment is not located within a vapour space of fuel oil tanks;

.3 there are no openings from the vapour space of the fuel tanks into machinery spaces;

.4 enclosed spaces shall not be located directly over such fuel tanks, except for well-ventilated cofferdams;

.5 ends of air pipes shall be equipped with flame arresters.

### 13.4 DRAINAGE ARRANGEMENTS OF FUEL OIL TANKS

**13.4.1** For draining water from the bottom of the daily service and settling tanks, these tanks shall be fitted with self-closing valves and pipes connected to drain tanks.

The drain pipes shall be fitted with sight glasses. Where trays are available, open funnels may be used instead of sight glasses.

### 13.5 ARRANGEMENTS FOR COLLECTION OF LEAKAGE FUEL

**13.5.1** Tanks, pumps, filters and other equipment shall be fitted with drip trays where there is a possibility of fuel oil leakage.

**13.5.2** Drain pipes from the drip trays shall be laid into fuel oil drain tanks.

Drainage of fuel oil into the bilges and overflow tanks is not permitted.

**13.5.3** The internal diameter of the drain pipes shall be at least 25 mm.

**13.5.4** The ends of the drain pipes shall be laid to the tank bottom with a gap not less than 1/4 of the internal diameter of the pipe.

Where the drain tank is situated in the double-bottom space, structural measures shall be taken to prevent penetration of water into the machinery spaces through the open ends of the drain pipes in the event of damage to the shell plating.

Provision shall be made for an alarm device to give warning if the fuel oil reaches the upper predetermined level in the drain tank.

**13.5.5** If drain pipes from drip trays fitted in different watertight compartments are laid into a common drain tank, structural precautions shall be made to prevent water from one flooded compartment to enter the other compartment via the open ends of drains.

### 13.6 FILLING OF STORAGE TANKS

**13.6.1** The bunkering of the ship shall be carried out through a permanent pipeline, provided with the valves necessary for the filling of all the basic fuel storage tanks.

In ships with twin hulls, the filling pipes shall ensure the filling of the fuel tanks of any of the hulls as well as pumping of fuel from the tanks of one hull into the tanks of the other.

The end of the filling pipe shall be laid to the tank bottom with a gap not less than 1/4 of the internal diameter of the pipe or by other means excluding foaming when filling the tank.

**13.6.2** In passenger ships provision shall be made for bunkering stations, which are separated from the other spaces, and fitted with drain pipes laid into fuel oil drain tanks.

**13.6.3** The filling pipes of the tanks situated above the double bottom shall be connected to the tanks near the top.

Where this is impracticable, the filling pipes shall be fitted with non-return valves installed directly on the tanks.

Where the filling pipe is used as a suction pipe, the non-return valve shall be replaced by a remote-controlled shut-off valve operable from accessible position outside the space, in which the tank is located.

### 13.7 FUEL OIL TANKS

**13.7.1** The structural members of fuel oil tanks shall comply with the requirements of Part II "Hull".

**13.7.2** The arrangement of the fuel tanks in the machinery spaces shall comply with the requirements of 4.3, Part VII "Machinery Installations".

**13.7.3** The fuel tanks situated on weather decks and superstructure decks, as shall be protected against the action of sunrays.

**13.7.4** In glass-reinforced plastic ships (refer to 2.8, Part XVI "Hull Structure and Strength of Glass-Reinforced Plastic Ships and Boats") the fuel tanks shall not directly adjoin the accommodation spaces.

The air gap between the fuel tank and accommodation space shall be efficiently ventilated.

In general, the fuel tanks shall not be located in machinery spaces. If they are located in such spaces, they shall be constructed of steel or equivalent material (refer to 1.2, Part VI "Fire Protection").

**13.7.5** Fuel oil tanks shall be separated from the feed water and vegetable oil tanks by cofferdams, the structural members of which shall comply with the requirements of Part II "Hull".

**13.7.6** In ships of 400 gross tonnage and upwards, compartments situated forward of the collision bulkhead shall not be used for carriage of fuel oil or other flammable liquids.

**13.7.7** In ships having distinguishing mark of provision with means for fire fighting on other ships in the class notation the fuel oil tanks shall contain fuel oil reserve sufficient to provide the operation of pumps of special fire-extinguishing systems during 24 h for ships with distinguishing mark **FF3WS** and 72 h for ships with distinguishing marks **FF1**, **FF1WS**, **FF2** or **FF2WS**.

**13.7.8** On oil and chemical tankers, fuel oil tanks adjacent to cargo tanks shall not be situated within the cargo tank block. Such tanks may, however, be situated at the forward and aft ends of the cargo tank block instead of cofferdams. Fuel tanks shall extend neither fully nor partly into cargo or slop tanks. They may however be accepted when located as independent tanks on open deck in the cargo area subject to spill and fire safety considerations. Fuel tanks are not permitted to extend into the protective area of cargo tanks required by MARPOL Annex I and the IBC Code. For chemical tankers due attention has to be paid to restrictions on cargoes that can be located in the immediate vicinity of fuel tanks.

The arrangement of independent fuel tanks and associated fuel piping systems, including the pumps, can be as for fuel tanks and associated fuel piping systems located in the machinery spaces. For electrical equipment, requirements to hazardous area classification shall however be taken into account.

Cargo tank block is the part of the ship extending from the aft bulkhead of the aftmost cargo or slop tank to the forward bulkhead of the forward most

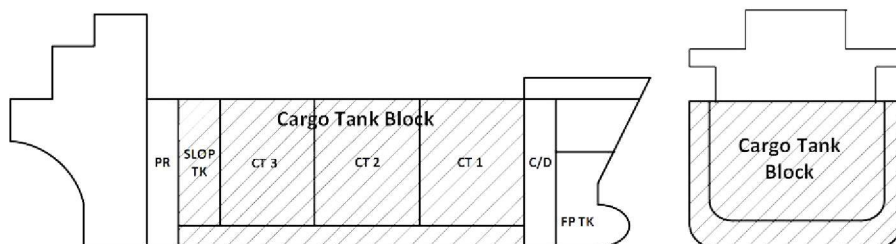

Fig. 13.7.8.

cargo or slop tank, extending to the full depth and beam of the ship, but not including the area above the deck of the cargo or slop tank (Fig. 13.7.8).

### 13.8 FUEL OIL SUPPLY TO INTERNAL COMBUSTION ENGINES

**13.8.1** The equipment of fuel system shall be capable of supplying fuel oil duly prepared and cleaned to the extent required for the given engine.

The main and auxiliary engines shall be supplied with fuel oil from two fuel oil service tanks for each type of fuel used on board.

The fuel oil service tank is considered to mean a tank containing only the fuel oil prepared for use, i.e. the fuel oil the grade and properties of which meet the requirements specified by a manufacturer of the equipment. The fuel oil service tank intended for a particular fuel oil grade shall be marked accordingly and need not be used for other purposes.

The capacity of each tank shall be sufficient for 8 h operation of the main and auxiliary engines and boilers at maximum continuous rating.

The capacity of fuel oil service tanks in ships with an unattended machinery spaces and/or main machinery control room shall be sufficient for providing the machinery installation operation within the time period specified in 4.1.4 and 5.1.5, Part XV "Automation", otherwise equivalents shall be provided to ensure compliance with the above requirements.

Use of slop tanks as the fuel oil service tanks is not permitted.

The equipment of the fuel oil system with two service tanks for each type of fuel used on board and equivalent arrangements complying with the requirements for the most commonly used fuel oil systems are shown in Figs. 13.8.1-1 and 13.8.1-2.

The scheme shown on Fig. 13.8.1-1*b*, is applied in cases when the main and auxiliary engines can operate at all loads on heavy fuel oil; as applied to the main engines, heavy fuel oil can be used when starting and reversing them.

The schemes shown on Fig. 13.8.1-1*b* and Fig. 13.8.1-2*b* are applied only in cases when arrangements and systems are used providing a quick switch from one fuel oil grade to another and capable of operating on two fuel oil grades at sea under all normal operating conditions.

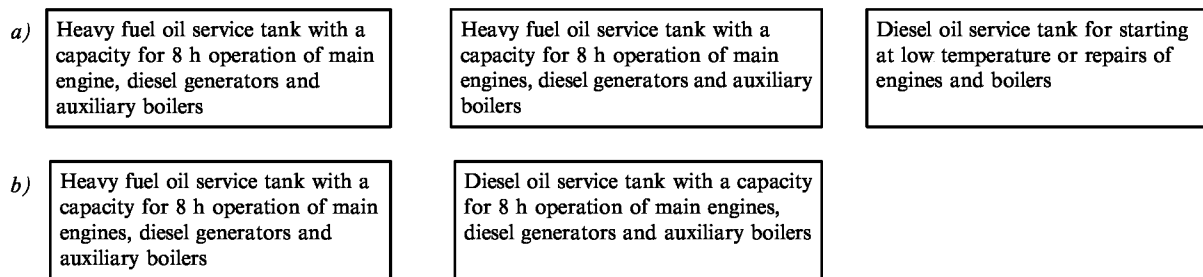

Fig. 13.8.1-1 Heavy fuel oil service tanks for main and auxiliary engines and auxiliary boilers fuel supply: *a* — tanks required by SOLAS-74 Convention; *b* — tanks equivalent to those required by the Convention.

Note. Where pilot burners are used in auxiliary boilers, an additional diesel oil tank with a capacity for 8 h operation may be required

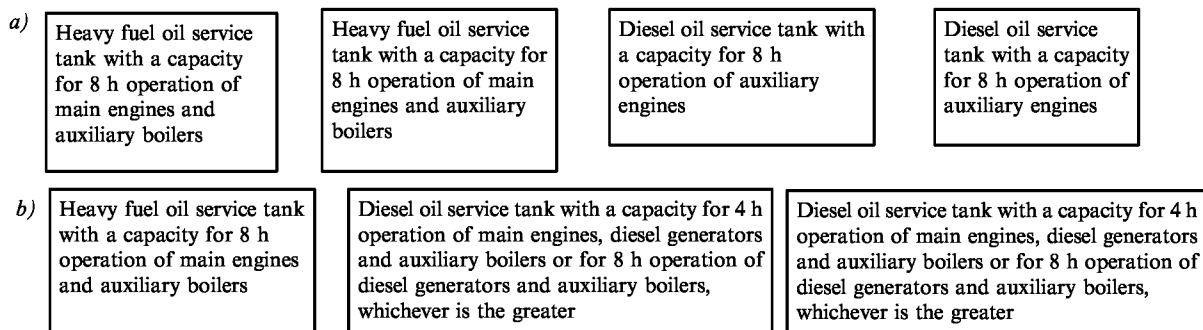

Fig. 13.8.1-2 Fuel oil service tanks for main engines and auxiliary boilers and diesel oil service tanks for auxiliary engines: *a* — tanks required by SOLAS-74 Convention; *b* — tanks equivalent to those required by the Convention

Exemption from these requirements may be granted by the Register for fishing ships, ships of less than 500 gross tonnage, as well as for dredging ships, ships less than 24 m in length and berth-connected ships.

**13.8.2** The filters fitted in the fuel oil supply lines to the engines shall be such that any filter can be cleaned without interrupting the operation of the engine. The design and construction of filters shall meet the requirements of 4.2.

**13.8.3** When fuel oil is supplied to the engines, the following requirements shall be satisfied:

**.1** where one booster pump is fitted to serve the main engines, except where the machinery installation comprises two or more engines, each having its own booster pump, the arrangements shall be such that the engines are supplied with fuel oil in the event of damage to the booster pump;

**.2** where fuel oil is supplied to engines forming part of machinery installations comprising two or more main engines supplied with fuel oil from a single source, arrangements shall be provided to cut off fuel oil supply to each individual engine. The cut off valves shall be remotely operated from the control station (refer also to 3.2.1.11, Part VII "Machinery Installations").

The Register may grant an exemption for cargo ships of less than 500 gross tonnage that navigate in restricted areas **R2**, **R2-RSN**, **R2-RSN(4,5)**, **R3-RSN** and **R3**.

**13.8.4** Where the engines operate on different grades of fuel, precautions shall be taken to prevent auxiliary engines and other consumers from being supplied with fuel that is unfit for their operation.

**13.8.5** The diesel-generating sets intended for use as emergency units shall be supplied with fuel from an independent daily service tank situated in the emergency diesel generator room. Consumption of fuel from this tank by other consumers is not allowed, except cases specified in 9.4.2, Part XI "Electrical Equipment" provided the requirements of 2.2.6, Part IX "Machinery" are complied with. The tank capacity shall be such as to ensure operation of the diesel generator for the period stated in 9.3.1, 9.3.8, and 19.1.2.1, Part XI "Electrical Equipment". When emergency diesel generator is used for feeding consumers not in an emergency condition during the ship's moorage as well as in case of its use as a means to ensure that the machinery can be brought into operation from the dead ship condition (refer to 2.1.6, Part VII "Machinery Installations"), provision shall be made of automatic refilling of emergency diesel generator daily service tank and of low-level alarm corresponding to the volume of the emergency diesel-generator daily service tank.

**13.8.6** The fuel oil system shall be provided with inspection and measuring instruments in accordance with 2.1.2, Part IX "Machinery". Sight glasses on pipelines shall be heat-resistant.

**13.8.7** Fuel system components and connections within fuel supply lines shall be designed considering the maximum peak pressure to be experienced in service including any high pressure pulses and hydraulic impacts, which are generated and transmitted back into the fuel supply and spill lines by the action of fuel injection pumps.

### 13.9 FUEL OIL SUPPLY TO BOILERS

**13.9.1** The fuel oil supply system with mechanical atomization, serving the main boilers and the auxiliary boilers for essential services (refer to 1.2, Part X "Boilers, Heat Exchangers and Pressure Vessels") shall include at least two sets of fuel pumps, suction and discharge filters.

Each set of machinery shall be calculated for the full steam generating capacity of the boilers served.

Apart from the local controls, the fuel pumps shall have means enabling them to be stopped from easily accessible positions outside the spaces, in which they are situated.

The main boilers shall generally be supplied from two fuel tanks.

**13.9.2** The pumps supplying fuel oil to the boilers shall not be used for other purposes.

**13.9.3** The pipes conveying fuel oil to the burners of each boiler shall be fitted with a quick-closing valve operated by hand.

This requirement is applicable to the boilers put into action by hand igniters and also to boilers with gravity feed of fuel oil to the burners.

**13.9.4** Where fuel oil is fed to the burners by gravity, filters shall be fitted in the supply pipeline to the burners.

**13.9.5** It shall be possible to bring the main boilers into operation without having to recourse to a source of power outside the ship.

**13.9.6** If the fuel tanks of main and essential auxiliary boilers are used also as water ballast tanks, provision shall be made for settling tanks.

Where two daily service tanks are available, settling tanks need not be provided.

**13.9.7** The oil burning installation of the boilers shall comply with the requirements of Section 5, Part X "Boilers, Heat Exchangers and Pressure Vessels".

**13.9.8** Thermometers and pressure gauges shall be installed in suitable positions on the pipes supplying fuel oil to the burners.

### 13.10 FUEL OIL SUPPLY TO GAS TURBINES

**13.10.1** The main gas turbine shall have at least two fuel feed pumps: main and standby, of which one may be driven from the main turbine. The capacity of the standby pump shall not be less than that of the main pump.

Where there are two gas turbines or more, one independent standby pump will suffice.

**13.10.2** The fuel oil system of a gas turbine shall comply with the requirements of 13.8 of the present Part and 8.5.4, Part IX "Machinery".

### 13.11 USE OF CRUDE OIL OR SLOPS AS FUEL FOR TANKER BOILERS

**13.11.1** In oil tankers crude oil or slops may be used as fuel for main and auxiliary boilers according to the following requirements.

For this purpose, all arrangement drawings of a crude oil installation with pipeline layout and safety equipment shall be submitted to the Register for approval.

**13.11.2** Crude oil or slops may be taken directly from cargo tanks or flow slop tanks fitted in the cargo tank area. They shall be separated from non-gas-dangerous areas by means of cofferdams with gastight bulkheads.

**13.11.3** The construction and workmanship of the boilers and burners shall be proved to be satisfactory in operation with crude oil.

The outer hood of the boilers shall be gastight separated from the engine room.

The boilers themselves shall be tested for gastightness before being used.

The whole system of pumps, strainers, separators and heaters, if any, shall be fitted in the cargo pump room or in another room, to be considered as dangerous and separated from engine and boiler room by gastight bulkheads.

Where crude oil is heated by steam or hot water, the outlet of the heating coils shall be laid to a separate observation tank installed together with the above-mentioned components.

This closed tank shall be fitted with a venting pipe laid to the atmosphere in a safe position according to the requirements of 10.1.6 for oil tankers. The venting pipe outlet shall be fitted with easily removable flame proof wire gauze.

**13.11.4** The arrangement of prime movers of pumps, separators, etc. shall comply with the requirements of 4.2.5, Part VII "Machinery Installations".

**13.11.5** The pumps shall be fitted with a pressure relief bypass from delivery to suction side.

It shall be possible to stop them by a remote control placed in a position near the boiler fronts or main machinery control room and from outside the engine room.

**13.11.6** When it is necessary to preheat crude oil or slops, their temperature shall be automatically controlled and a high temperature alarm shall be fitted.

**13.11.7** The piping for crude oil or slops and the draining pipes for the tray defined in 13.11.9 shall have wall thickness in compliance with column 5 of Table 2.3.8.

The number of connections for these pipes shall be minimum.

The pipe detachable connections shall be of the flange type and shall comply with the requirements of Table 2.4.3.3 for piping of Class I.

Within the engine room and boiler room these pipes shall be fitted within metal duct, which shall be gastight and tightly connected to the fore bulkhead separating the pump room and to the tray.

This duct (and the enclosed piping) shall be at an inclination rising towards the boiler so that the oil naturally returns towards the pump room in the case of leakage or failure in delivery pressure.

Besides, the duct shall be fitted at a distance from the ship's side of at least 20 per cent of the ship's beam amidships.

It shall be fitted with inspection openings with gastight doors in way of connections of pipes within it, with an automatic closing drain-trap placed on the pump room side, set in such a way as to discharge leakage of crude oil into the pump room.

In order to detect leakages, level position indicators with relevant alarms shall be fitted on the drainage tank specified in 13.11.9.

Also a vent pipe shall be fitted at the highest part of the duct and shall be laid to the open in a safe position according to the requirements of 10.1.6 for oil tankers. The outlet shall be fitted with easily removable flame proof wire gauze.

The duct shall be permanently connected to the inert gas system or steam supply in order to make possible:

injection of inert gas or steam in case of fire or leakage;

purging of the duct before carrying out work on the piping in case of leakage.

**13.11.8** In way of the bulkhead, to which the duct defined in 13.11.7 is connected, delivery and return oil pipes shall be fitted on the pump room side with shut-off valves remotely controlled from a position near the boiler fronts or from the main machinery control room.

The remote control valves shall be interlocked with the hood exhaust fans mentioned in 13.11.10 to ensure that whenever crude oil is circulating the fans are running.

**13.11.9** Boilers shall be fitted with a tray or gutterway of a height not less than 200 mm and be placed in such a way as to collect any possible oil leakage from burners, valves and connections.

Such a tray or gutterway shall be fitted with easily dismountable flame proof wire gauze at their upper part.

Delivery and return oil pipes shall pass through the tray or gutterway by means of a tight penetration and shall then be connected to the oil supply manifolds.

A quick closing master valve shall be fitted on the oil supply to each boiler manifold.

The tray or gutterway shall be fitted with a draining pipe discharging into a collecting tank in pump room. This tank shall be fitted with a venting pipe laid to the open in a safe position and with the outlet fitted with wire gauze easily dismountable for cleaning.

This draining pipe shall be fitted with arrangements to prevent the return of fuel oil to the boiler or engine room.

**13.11.10** The boilers shall be fitted with a suitable hood placed in such a way as to enclose as much as possible of the burners, valves and oil pipes, without preventing, on the other side, air inlet to burner register.

The hood, if necessary, shall have means of inspection and access to oil pipes and valves placed behind it.

It shall be fitted with a duct laid to the open in a safe position, the outlet of which shall be fitted with an easily dismountable flame wire gauze.

At least two mechanically driven exhaust fans having spark proof impellers shall be fitted so that the pressure inside the hood is less than that in the boiler room.

The exhaust fans shall be connected with automatic change-over in case of stoppage or failure of the one in operation.

The exhaust fan prime movers shall be placed outside the duct and a gastight bulkhead penetration shall be arranged for the shaft.

Electrical equipment installed in gas dangerous areas or in areas, which may become dangerous (i.e. in the hood or duct in which crude oil piping is placed), shall be of certified safe type.

**13.11.11** When using fuel oil for delivery to and return from boilers fuel oil burning units in accordance with 13.9 of this Part and Section 5, Part X "Boilers, Heat Exchangers and Pressure Vessels" shall be fitted in the boiler room.

Fuel oil delivery to, and returns from, burners shall be effected by means of a suitable mechanical interlocking device so that running on fuel oil automatically excludes running on crude oil or vice versa.

**13.11.12** The boiler compartments shall be fitted with a mechanical ventilation plant and shall be designed in such a way as to avoid the formation of

gas pockets. Ventilation shall be particularly efficient in way of electrical plants and machinery and other plants which may generate sparks. These plants shall be separated from those for service of other compartments and shall comply with the requirements of 12.4.

**13.11.13** A gas detector plant shall be fitted with intakes in the duct mentioned in 13.11.7, in the hood duct (downstream of the exhaust fans in way of the boilers) and in all zones where ventilation may be reduced.

Visual and audible alarm shall be installed near the boiler fronts, in the machinery space and in the main machinery control room.

**13.11.14** Means shall be provided for the boiler to be automatically purged before firing.

**13.11.15** Independent of the fixed fire extinguishing system required for engine and boiler rooms, an additional fire extinguishing plant (refer to 3.1.2.8, Part VI "Fire Protection") shall be fitted in such a way that it is possible for an approved fire extinguishing medium to be directed on to the boiler fronts and on to the tray defined in 13.11.9.

The emission of extinguishing medium shall automatically stop the exhaust fan of the boiler hood (refer also to 13.11.8).

**13.11.16** A warning notice shall be fitted in an easily visible position near the boiler front. This notice shall specify that when an explosive mixture is signalled by the gas detector plant defined in 13.11.13, the watchkeepers shall immediately shut off the remote controlled valves on the crude oil delivery and return pipes in the pump room, stop the relative pumps, inject inert gas into the duct mentioned in 13.11.7 and turn the boilers to normal running on fuel oil.

**13.11.17** The Register reserves the right to require installation of one pilot burner in addition to the normal burning control.

### **13.12 APPLICATION OF NATURAL GAS (METHANE) AS FUEL**

**13.12.1** Gas fuel piping shall not be laid through control stations, accommodation and service spaces.

Laying of gas fuel pipelines through other spaces is allowed in compliance with the requirements of 13.12.2 or 13.12.3.

**13.12.2** The pipeline represents a piping system with double walls containing gas fuel inside the internal pipe. The following conditions shall be met:

.1 the space between the walls shall be filled with inert gas under pressure exceeding gas fuel pressure;

.2 inert gas pressure shall be constantly monitored by the alarm system;

.3 at the alarm system actuation the automatic valves mentioned in 13.12.5 and the main gas valve indicated in 13.12.6 shall be automatically closed prior the inert gas pressure drops lower than the pressure of gas fuel, and vent valve stated in 13.12.5 shall be automatically opened;

.4 the system shall be arranged so that the internal part of gas fuel supply pipeline between the main gas valve and engine be automatically purged with inert gas, when the main gas valve is closed.

**13.12.3** Gas fuel pipelines shall be installed in the pipe or duct with artificial exhaust ventilation of the space between them. The capacity of exhaust ventilation shall be calculated basing on the velocity of gas fuel flow, structure and location of protective pipes or ducts and provide at least 30 air changes per hour.

Therewith the following conditions shall be met:

.1 the pressure in the space between the external and internal walls of pipelines or ducts shall be kept lower than the atmospheric pressure;

.2 provision shall be made for the gas leakage detector and the cut-off of the gas supply to the engine room;

.3 electrical motors shall be of explosion-proof design and be located outside the pipes and ducts;

.4 when the required air flow is not maintained by the ventilation system, the main gas valve, mentioned in 13.12.6, shall be closed automatically. Ventilation shall function every time when gas is supplied through the pipeline;

.5 air intakes of the ventilation system shall be provided with non-return devices. These requirements are not compulsory when gas detectors are fitted in the air intakes;

.6 provision shall be made for inertization and degasification of gas fuel pipeline system section located in the engine room.

**13.12.4** For the engine rooms of category A where gas fuel is used besides the requirements of 13.12.2 and 13.12.3 the additional requirements to ventilation shall be met.

**13.12.4.1** Engine rooms shall be fitted with ventilation system precluding gas pockets. Ventilation shall be particularly effective in the area of electrical equipment installation, machinery or other possible sources of spark formation.

The ventilation system shall be separated from ventilation of other spaces and meet the requirements of 12.5.

**13.12.4.2** Engine rooms shall be equipped with the effective gas detection system in the places of possible gas lock and leakage. When the concentration of gas is equal to 30 per cent of low flammability limit, the audible and visible alarms shall be actuated, and when the concentration of gas is equal to 60 per cent of low flammability limit, the supply of gas fuel to the engine room shall be cut off.

**13.12.5** Gas fuel supply system shall be fitted with three automatic valves. Two of them shall be installed in succession in the system of gas fuel supply to the engine. The third valve (ventilation) shall be mounted for gas discharge from the pipe section located between two automatic valves installed in succession to the safe place on the weather deck. The system shall be constructed so that when:

the pressure in the gas fuel supply pipeline fluctuates from the set values;

loss of energy for valve driving;

violation of the conditions stated in 13.12.2 and 13.12.3;

stop of the engine because of any reason;

two valves installed in succession shall be closed automatically and the third valve (ventilation) shall be opened automatically.

As an alternative, one of two valves installed in succession and the ventilation valve may be combined in one body, provided their performance of the above-mentioned functions.

All three valves shall be manually operated.

**13.12.6** The main gas valve shall be installed outside the engine room and be equipped with remote control to enable its closing from the engine room.

This valve shall to be automatically closed in the following cases:

leakage of gas fuel;

violation of the conditions stated in 13.12.2 and 13.12.3;

actuation of oil mist concentration sensor in the engine crankcase or in the temperature control system of the engine bearings.

It is advisable, that the main gas valve is automatically closed at the actuation of interlocked gas valves (refer to Table 9.7.1, Part IX "Machinery").

**13.12.7** Gas line shall have sufficient structural strength with regard to stresses caused by the mass of the pipeline, internal pressure, loads caused by bends of the ship's hull and accelerations.

**13.12.8** The structure of protective pipes or ducts of the ventilation system mentioned in 13.12.2 and 13.12.3 shall have strength sufficient to withstand fast increase of pressure in case of pipeline break. A number of split connections in protective pipes or ducts shall be minimum.

**13.12.9** As a rule, gas pipelines shall be connected with complete-penetration butt welds and special means for provision of weld root quality and completely radiographically tested.

All butt welds after welding are subjected to heat treatment depending on the material.

**13.12.10** The installation for gas fuel supply and reservoirs for its storage shall comply with the following requirements:

.1 the construction, control and safety system of gas compressors, pressure vessels and heat-exchangers incorporated in the gas fuel supply system, shall meet the requirements of the appropriate Parts of the Rules;

.2 during the design work and calculation the possibility of fatigue failure of gas pipelines because of vibration as well as fluctuation of pressure when gas fuel is supplied by the compressors, shall be taken into consideration.

13.12.11 Gas supply to dual-fuel engines and gas turbine engine shall meet the requirements of 8.10 and 9.8, Part IX "Machinery".

### 13.13 FUEL OIL SYSTEMS FOR HELICOPTERS

13.13.1 The fuel oil system for supplying other ships and helicopters with fuel having a flash point below 43 °C shall comply with the requirements of 6.5, Part XVII "Distinguishing Marks and Descriptive Notations in the Class Notation Specifying Structural and Operational Particulars of Ships".

13.13.2 An fuel oil pump shall take in fuel oil simultaneously from one tank only. Pipelines shall be made of steel or equivalent material, shall be short (where possible) and shall be protected against damages.

13.13.3 Fuel oil pumps shall be provided with shutdown means positioned in a remote safe place. Service tanks shall be provided with quick-closing valves driven from outside the tank area.

13.13.4 Tanks for helicopter fuel shall be arranged in compliance with 6.1.14 to 6.1.17, Part VI "Fire Protection".

13.13.5 A fuelling pipeline shall be provided with a safety device, which prevents the excess of pressure in a fuelling hose above the permissible one.

13.13.6 All pipelines and equipment of the system for bunkering, storage and fuelling shall be electrically continuous and shall be earthed to the ship hull.

13.13.7 Each fuel oil tank shall be fitted with filling, outlet, sounding and air pipes. The end of a filling pipe shall not be more than 300 mm above a tank bottom. It is recommended to use closed-type flow-meters. The sounding pipe shall end 30 to 50 mm above a tank bottom and shall be laid to the open deck.

13.13.8 Air pipes of fuel oil tanks shall be laid to a height of at least 2,4 m above the open deck. Open ends of air pipes shall be spaced at a distance of at least 10 m from air in-takes and openings of enclosed spaces with ignition sources, and from a deck machinery and equipment, which may present an ignition hazard, and shall be fitted with flame-arresting meshes or other fittings approved by the Register.

### 13.14 LIQUEFIED GAS SYSTEM FOR DOMESTIC NEEDS

13.14.1 The use of gas meeting the requirements of current national standards is permitted.

13.14.2 Liquefied gas may be used for galley ranges, as also for straight-through liquid heaters (including provision refrigerators) consuming not more than 1 kg of liquefied gas per hour.

13.14.3 Only standard gas containers and gas-consuming appliances of type approved by competent technical supervision bodies may be installed on board the ship.

13.14.4 An automatic safety gas shut-off device shall be fitted on gas-consuming appliances, which operates in the event of flame failure.

For straight-through heaters this device shall have check flame.

13.14.5 Gas containers shall be stowed in a special compartment on the open deck, complying with the requirements of 2.1.5.3, Part VI "Fire Protection" with direct access to the open deck.

Where provision is made for stowage of not more than two gas containers, they may be arranged in an enclosed recess in the superstructure or deckhouse, or in a steel locker.

Furthermore, the stowage compartment for gas containers shall meet the following requirements:

.1 efficient natural ventilation shall be provided, account being taken of the provisions of 12.1.4 and 12.4.6.

In addition to natural ventilation, mechanical ventilation may be used, the requirements of 12.1.4 being taken into consideration;

.2 where necessary, structural arrangements shall be made to maintain the temperature in the compartment not exceeding + 50 °C;

.3 electric illumination and electrical equipment at a distance of 2 m from openings to the compartment shall comply with the requirements of 2.9, Part XI "Electrical Equipment";

.4 a warning notice recalling of the risk of explosion and prohibiting the use of naked flame and smoking shall be displayed on the door.

13.14.6 The installation of gas containers in the compartment shall comply with the following requirements:

.1 cylinders shall be installed with stop valves upwards and be secured with quick-detachable arrangements. Other measures shall be taken to quickly release containers;

.2 a reducing valve shall generally be fitted on the container head; in this case, flexible hose of approved type may be used for connection of the reducing valve to the liquefied gas pipeline;

.3 if a group of containers is connected to the manifold, only one reducing valve shall be fitted between each container and the manifold; in this case, containers shall be connected to manifold by copper pipes;

.4 where more than one container is connected to the manifold, shut-off valve or cock shall be fitted between each container and the manifold. A notice prohibiting the simultaneous use of more than one container shall be displayed in the compartment.

**13.14.7** Compartments containing gas-consuming appliances shall be equipped in compliance with 2.1.5.2, Part VI "Fire Protection" and meet the following requirements:

.1 they shall not be arranged below the upper deck and be provided with efficient natural ventilation for extraction of combustion products and air taking from the lower part of the compartment;

.2 where the compartment is partially below the open deck, it shall be provided with mechanical ventilation;

.3 straight-through gas-consuming appliances shall be provided with separate lines for removal of combustion products.

**13.14.8** Pipes shall be of seamless steel or copper. Steel pipes shall be protected against corrosion.

**13.14.9** The thickness of pipe walls shall meet the requirements of column 2 or 8, Table 2.3.8.

**13.14.10** Pipes from gas containers to gas-consuming appliances shall be laid over the open deck and be protected against mechanical damages.

**13.14.11** Pipe joints shall be welded. Threaded or flange joints are permitted only in places of connection of instrumentation lines, gas-consuming appliances and valves.

**13.14.12** A shut-off valve or cock shall be fitted on the pipe where it pierces the bulkhead of the container compartment, this valve or cock being operated from outside the compartment. The valve or cock shall be provided with a turning limiter and a plug position indicator.

**13.14.13** Where more than one gas-consuming appliance is installed, a shut-off valve or cock provided with a turning limiter and a plug position indicator shall be fitted on branches from a common pipe line to each gas-consuming appliance.

Where these valves or cocks are fitted in the container compartment, provision shall be made for their operation from outside the compartment; in this

case, the installation of a cock or valve on the common pipe line may be omitted (refer to 13.14.12).

**13.14.14** The reducing valve shall provide the pressure of not more than 5 kPa in the system.

**13.14.15** The reducing valve or the pipe line after it shall be provided with a safety valve with a setting pressure less than 7 kPa with gas outlets piped to a safe place of the upper deck.

Where the reducing valve is so designed that gas outlet to a low pressure pipe line is closed in case of failure or break of the diaphragm, the safety valve need not be provided.

**13.14.16** Valves shall be of bronze, brass or other corrosion-resistant material.

**13.14.17** Liquefied gas pipe lines from containers to reducing valves shall be tested:

in ship, by hydraulic pressure of 2,5 MPa;

in ship, by air pressure of 1,7 MPa.

Pipelines from reducing valves to gas-consuming appliances shall be tested by air pressure of 0,02 MPa after installation on board.

#### **13.15 FUEL OIL SUPPLY SYSTEM FOR GALLEY EQUIPMENT**

**13.15.1** It is permitted to use fuel oil with a flash point not less than 60 °C for galley equipment.

**13.15.2** The capacity of fuel oil service tanks located in galleys shall not exceed the daily consumption requirement.

**13.15.3** A shut-off valve on the supply pipe shall be remotely controlled from readily accessible place outside the galley. It is recommended to use quick-closing type valves.

**13.15.4** Tanks, fuel oil pumps and heaters shall be placed at least 2 m from the nearest point on the heating equipment, and at a 0,5 m distance from the same in the plan view of the place.

**13.15.5** If the galley space is sufficiently large, fuel oil tanks, pumps and other appliances of the fuel oil system shall be placed in special enclosures.

**13.15.6** All oil-fired equipment, burners included, shall be fitted with trays underneath (or an equivalent protection provided directly on the steel deck), with beads not less than 75 mm in height, extending not less than 100 mm outside the equipment perimeter.

## 14 LUBRICATING OIL SYSTEM

### 14.1 LUBRICATING OIL PUMPS OF INTERNAL COMBUSTION ENGINES, GEARS AND COUPLINGS

**14.1.1** For an installation with one main engine provision shall be made for not less than two lubricating oil pumps, main and standby, of the same capacity. One of these pumps may be driven from the main engine.

**14.1.2** Where two or more main engines are installed, each of them shall have its own lube oil pump, with provision for one stand-by pump driven independently and having a capacity sufficient to ensure the operation of each engine.

It is permitted to have on the ship a spare pump as stand-by provided that it is accessible for mounting in operational conditions.

**14.1.3** In cargo ships of less than 500 gross tonnage navigating in restricted areas **R2**, **R2-RSN**, **R2-RSN(4,5)**, **R3-RSN** and **R3** standby pumps may not be installed irrespective of the number of main engines.

This exception shall not apply to the following ships of restricted navigation area **R2**:

tugs with one main engine;

passenger ships with one main engine.

**14.1.4** Where the turbo-blowers of the main engine have an independent electrically driven lubricating oil pump, provision shall be made for a standby pump of adequate capacity and a gravity tank containing sufficient oil to maintain lubrication of the turbo-blowers during idle rotation if the oil pump stops working.

Warning alarms shall operate for low level in the tank and automatic start-up of standby pump shall be ensured at stoppage of the pump at work.

Means shall be provided to enable the oil flow in turbo-blower bearings to be controlled.

**14.1.5** Lubricating oil pumps of main gearing, as well as the pumps supplying the main fluid couplings, shall comply with the requirements of 14.1.1 to 14.1.3 for the main engines.

**14.1.6** Each auxiliary engine and each emergency diesel generator engine (refer to 2.2.5, Part IX "Machinery") shall have a separate lubricating system.

**14.1.7** The lubrication of oil-lubricated sterntube bearings shall comply with the requirements of 5.6.3 and 5.6.4, Part VII "Machinery Installations".

### 14.2 LUBRICATING OIL SUPPLY TO INTERNAL COMBUSTION ENGINES AND GEARS

**14.2.1** The design of a lubricating oil drain tank and the operating oil level in it, as well as the

arrangement of pump suction pipes shall prevent a lubricating oil flow separation at the maximum static and dynamic heel and trim angles, which are probable for the given ship. The lubricating oil drain pipes from the engine crankcase shall terminate in the oil drain tank so as to be submerged in oil all the time of the engine operation. No communication is permitted between lubricating oil drain pipes of two or more engines.

**14.2.2** The pipes of the lubricating oil system shall not communicate with other piping systems, except where they are connected to separators, which may be used for fuel oil separation. In the latter case, arrangements shall be fitted, which will preclude mixing of fuel oil and lubricating oil.

While separating a lube oil, precautions shall be taken to prevent mixing of lubricating oils of different specifications.

**14.2.3** The lubrication system shall provide effective cleaning of oil, for which purpose filters shall be fitted as follows:

**.1** magnetic filter generally on the suction side of the pump of the gears;

**.2** one coarse filter (strainer) on the suction side of the main engine pump; two parallel filters or one duplex filter or a self-cleaning filter on the discharge side of the main engine pump. The design and construction of filters shall meet the requirements of 4.2 and 13.8.2.

**14.2.4** The capacity of each oil filter shall exceed by 10 per cent the maximum capacity of the pump.

**14.2.5** The lubricating system shall be fitted with instrumentation in accordance with 2.12, Part IX "Machinery".

The pressure gauge indicating the pressure after the oil cooler shall be placed at the control station.

### 14.3 LUBRICATING OIL PUMPS OF STEAM TURBINES AND GEARS

**14.3.1** The lubricating oil system of the main turbine set shall be serviced by two oil pumps, the capacity of each pump being sufficient to ensure lubrication of the turbine set for maximum output condition. At least one of the pumps shall be independently driven.

Where two main turbine sets are arranged in the same space, one independent standby pump may be fitted for both turbine sets.

**14.3.2** Lubricating oil pumps shall be of self-priming type and shall be so disposed that reliable start-up is always possible.

**14.3.3** In general, the lubricating oil for main turbine sets shall be supplied from the gravity tank,

with arrangements to be such that lubrication is supplied to the turbines also in the event of damage to the main oil pump, and until the turbines come to rest at failure in power supply from the main sources of power to the motors of oil pumps.

#### 14.4 LUBRICATING OIL SUPPLY TO STEAM TURBINES AND GEARS

**14.4.1** The circulating oil pipe line, including all branch pipes of consumers, shall be made of copper, bimetal, cupro-nickel or equivalent materials.

**14.4.2** Oil may be taken from the main turbine lubricating system only for control, adjustment and protection needs, as well as for lubricating the main thrust bearing.

**14.4.3** Each lubricating system shall be fitted with audible and visual alarms warning of oil pressure drop and placed at the main turbine control station. In gravity lubrication system, the alarms shall operate at such level in the gravity tank as to enable the protection devices to cut in the standby pump during the time left before the tank is emptied.

**14.4.4** The capacity of the gravity tank shall not be less than a 5-minute consumption of oil, with the turbine running at rated output.

The tank shall be fitted with an overflow pipe with a sight glass well lighted and visible from the control station. The cross-sectional area of the overflow pipe shall be at least 1,25 times that of the discharge pipe of the pump.

It shall be possible to supply lubricating oil to consumers from the pump, excepting the tank.

**14.4.5** The lubrication system of the main turbine set shall be fitted with two oil coolers, one of which is a standby cooler.

Where two turbine sets are situated in the same space, one standby oil cooler may be installed for both turbine sets.

Servicing of oil coolers shall be provided according to 15.1.7.

**14.4.6** The lubrication system of the main turbine sets and associated gearing shall comply with the requirements of 14.1.6, 14.2.3 and 14.2.5.

**14.4.7** The branch pipes of the circulating oil pipeline shall be fitted with throttle valves for regulating the amount of oil supplied to each consumer.

#### 14.5 LUBRICATING OIL TANKS

**14.5.1** The lubricating oil tanks shall be separated from the feed water and vegetable oil tanks by

cofferdams, the structural members of which shall comply with the requirements of Part II "Hull".

**14.5.2** The lubricating oil drain tanks in ships with main turbines shall in any case be separated from the bottom shell plating by a cofferdam, the structural members of which shall comply with the requirements of Part II "Hull".

For other ships, the arrangement of cofferdams is recommended.

Where the cofferdams are not available, the drain pipes from crankcases shall have non-return or shut-off valves capable of being operated from above the engine room floor plating.

In these cases lubricating oil drain tanks shall be provided with the relevant pipelines with valves for emergency lubricating oil suction by pumps from engines crankcases if tanks are holed.

Valves shall have drives located above the engine room plating.

**14.5.3** Provision shall be made for a lubricating oil storage tank with a capacity sufficient for filling the system with oil to the working condition.

This tank is recommended to be situated outside the double bottom.

In ships of restricted areas of navigation **R2** and **R3**, the lubricating oil storage tank need not be provided.

**14.5.4** The suction pipes from the tank situated outside the double bottom shall be fitted with shut-off valves installed directly on the tanks. Such cocks or valves may be fitted on straight branch pipes welded to the shell plating, provided they are rigid enough and have the minimum length.

In tanks of a capacity of more than 500 l which, with the exception of gravity lubrication systems, may be open in normal conditions, such valves shall be remote-controlled from always accessible positions outside the space containing the tank.

**14.5.5** Arrangements for heating of the lubricating oil shall comply with the requirements of 13.3.

**14.5.6** For lubricating oil tanks arranged in machinery spaces of category A (refer to 1.2, Part VII "Machinery Installations") and, whenever practicable, in other machinery spaces, the requirements of 10.4, 13.5.1 and 13.6 of this Part and 4.3.3, 4.3.4, Part VII "Machinery Installations", shall be complied with, as far as lubricating oil tanks installed above heated surfaces of engines and machinery are concerned.

#### 14.6 ARRANGEMENTS FOR COLLECTION OF LEAKAGE LUBRICATING OIL

**14.6.1** The requirements of 13.5 apply to arrangements for collection of leakage lubricating oil.

**14.7 LUBRICATING OIL SUPPLY  
TO GAS TURBINES**

**14.7.1** The lubricating oil system of a gas turbine plant shall comply with the requirements of 14.1 to 14.5 as far as these requirements are applicable to the given plant.

## 15 WATER COOLING SYSTEM

### 15.1 PUMPS

**15.1.1** Water cooling systems of main engines shall comply with the following requirements:

**.1** a sea water cooling system of one main engine shall include two cooling water pumps, one of which is standby. The capacity of the standby pump shall not be less than that of the main pump. At least, one pump shall be driven independently.

A fresh water cooling system of the main engine shall also comply with these requirements.

One common independent standby pump may be used for both fresh and salt water cooling; the capacity of this pump shall not be less than that of the main pumps; precautions shall be taken to prevent mixing of fresh and salt water;

**.2** one independent standby pump ensuring the operation of each engine running at maximum load shall be installed in a salt water cooling system of two and more main engines, each served by a separate cooling water pump.

No standby pump may be provided where a reserve pump is available, which may be assembled on board.

A fresh water cooling system shall also comply with these requirements.

It is permitted to install one common independent standby pump, the capacity of which shall ensure fresh or sea water cooling of any engine; precautions shall be taken to prevent mixing of fresh and salt water;

**.3** it is allowed to cool several engines by one independently driven pump. In this case, the capacity of the pump shall be sufficient for simultaneous cooling of all engines when running at maximum load. One standby pump, the capacity of which shall not be less than that of the main pump cooling simultaneously all engines, shall be provided.

The cooling pipe shall have a water control valve at inlet to each engine;

**.4** in installations of ships with an automation mark in the class notation provision shall be made for separate fresh water and salt water standby pumps, the capacity of which shall not be less than that of the main pumps;

**.5** in ships of restricted areas of navigation, special standby facilities are not compulsory; however, it shall be possible to cool the engine by sea water directly.

In ships of restricted areas of navigation **R2**, **R2-RSN**, **R2-RSN(4,5)**, **R3-RSN** and **R3** having two and more main engines direct standby sea water cooling is not compulsory.

**15.1.2** The oil and air coolers of the electric propulsion motors shall have standby means of cooling, equivalent to the main means.

**15.1.3** Where each of the auxiliary engines is provided with an independent cooling water pump, the standby pumps for these engines are not required.

Where, however, a group of auxiliaries is supplied with cooling water from a common system, one standby pump for salt water and fresh water is sufficient.

If a common cooling line is fitted for the main and auxiliary engines, standby pumps for cooling the auxiliary engines are not required.

For the diesel-generators kept ready for immediate use (hot condition) continuous priming with hot water shall be possible, where necessary.

**15.1.4** The ballast, bilge or other general service pumps operated only for clean water may be used as standby cooling pumps.

The use of fire pumps for this purpose is permitted if the requirements contained in 3.2.3.2, Part VI "Fire Protection", are complied with.

**15.1.5** An independent cooling system for pistons shall include a standby pump with a capacity not less than that of the main pump.

**15.1.6** An independent cooling system of the fuel valves shall include a standby pump with a capacity not less than that of the main pump.

**15.1.7** The oil coolers of the main turbine sets shall generally be served by the circulating pumps of the main condensers.

Where for servicing the oil coolers an independent circulating pump is fitted, provision shall be made also for a standby pump having a capacity of at least 0,66 of the consumption of water for the oil cooler, with the turbine running at rated output.

Any one general service pump may be used as a standby pump.

**15.1.8** A reserve pump with a capacity not less than that of the main pump shall be provided in an independent sea water cooling and lubricating system for stern bearings. Any sea water general purpose pump referred to in 15.1.4 may be used as a reserve pump.

### 15.2 PIPING LAYING

**15.2.1** Sea water cooling system shall be supplied from at least two sea chests or ice boxes (bottom and side) arranged in the engine room and interconnected. In cargo ships of less than 500 gross tonnage navigating in restricted areas **R2**, **R2-RSN**, **R2-RSN(4,5)**, **R3-RSN** and **R3** only one sea inlet shall be used.

**15.2.2** It is recommended that the cooling systems servicing the auxiliary engines and condensers of auxiliary turbines shall be supplied with water from separate sea inlets. Where these sea inlets are located

in the engine room, the suctions of the above-mentioned systems shall be connected through isolating valves to the cooling main supplied from sea inlets and/or ice boxes according to 15.2.1.

**15.2.3** The requirements for design of sea chests and ice boxes in ice class ships and icebreakers are given in 4.3.1.

### 15.3 COOLING WATER FILTERS

**15.3.1** Filters shall be fitted on the suction lines of water cooling system servicing the main and auxiliary engines. Filters shall be provided with a facility that makes it possible to be sure, before the filters are opened up, that there is no pressure. Means shall be provided to enable the filters to be cleaned without having to stop the cooling pumps.

In a water cooling system of a turbine installation, filters are recommended to be fitted.

### 15.4 COOLING OF INTERNAL COMBUSTION ENGINES

**15.4.1** In a fresh water cooling system of the engine provision shall be made for an expansion tank where the level of water is higher than the maximum level of water in the engine. The expansion tank shall be connected to the suction piping of the pumps and may be common for the cooling system of several engines.

The tank shall be provided with a device for monitoring the water level.

In the cooling system of engines, the arrangement of the sea water discharge pipes shall be such that the highest cooled spaces of the engines, air coolers and oil coolers are always filled with water and formation of trapped zones is excluded.

**15.4.2** The cooling system shall be fitted with thermometers and temperature control devices.

It is recommended that suitable alarms shall be provided to warn on the limit value of the cooling water temperature (refer to 2.12, Part IX "Machinery").

**15.4.3** The cooling system of an engine to be used as emergency engine shall comply with the requirements of 2.2.5, Part IX "Machinery".

**15.4.4** Where fuel oil or lubricating oil is used in the cooling systems of nozzles or pistons, such

systems shall comply with Section 13 or Section 14, accordingly.

### 15.5 COOLING OF GAS TURBINE INSTALLATIONS

**15.5.1** The cooling system of turbine casings shall comply with the requirements indicated in 15.4.

**15.5.2** Only fresh water cooling shall be used for turbine casings.

Sea water cooling may be admitted in the event of failure of the main cooling water pump.

**15.5.3** The cooling system of the air cooler shall comply with the requirements of 19.2.1, 19.2.3 and 19.3.1.

The standby pump may not be provided, if in the event of failure in water supply to the air coolers, 30 per cent of turbine rating is maintained.

### 15.6 SEA-WATER COOLING SYSTEMS

**15.6.1** As a rule, cooling systems fitted with keel sea coolers shall not be used in icebreakers and Arc4 to Arc9 ice class ships.

However, application of such cooling systems on Arc4 ice class ships may be allowed if thickness of the used cooling ducts is not less than the side hull plating and the ship's speed is maintained in case of damage of any cooling duct.

**15.6.2** For ships equipped with one main engine not less than two sea-water coolers, one of which is stand-by, shall be provided.

**15.6.3** For ships equipped with two or more main engines one stand-by cooler shall be provided to keep each engine running. The stand-by cooler may not be fitted if the system allows two engines operate using one cooler.

**15.6.4** For ships of restricted area of navigation equipped with two or more main engines the stand-by sea-water cooler may not be fitted.

**15.6.5** On the pipelines for supply and rejection of cooled medium to coolers the check valves shall be provided.

**15.6.6** Provision shall be made for drainage or purging of cooler.

**15.6.7** Each cooler shall be provided with air discharge arrangement.

## 16 COMPRESSED AIR SYSTEM

### 16.1 NUMBER AND CAPACITY OF STARTING AIR RECEIVERS

**16.1.1** The compressed air system of the main engines shall ensure simultaneous starting and reversing of all the main engines and starting arrangements shall comply with the requirements of 2.9, Part IX "Machinery".

The requirements for the compressed air system of gas turbines are given in 8.1.5, Part IX "Machinery".

**16.1.2** The total amount of starting air for the main engines starting and the associated pneumatic control systems shall be stored in not less than two air receivers or two groups of them so arranged that they may be used independently; the capacity of each air receiver, or each group of air receivers shall be at least 50 per cent of that required in 16.1.3 and 16.1.4 (refer also to 16.1.6).

Where an electric tyfon is used in ships of restricted areas of navigation **R2** and **R3**, it is permitted to fit one air receiver of a capacity sufficient to meet the requirements of 16.1.3 and 16.1.4.

**16.1.3** The total capacity of air receivers for starting and reversing of the main engines shall be sufficient to provide not less than 12 starts alternating between "ahead" and "astern" of each engine in ready to start condition, as well as the function of engine control systems.

**16.1.4** The total capacity of air receivers for starting of the main engines connected to a controllable pitch propeller or some other device, enabling to start without opposite torque, shall be sufficient to provide not less than 6 starts of each engine being in ready to start condition, and where there are more than two engines, at least 3 starts of each engine. At the same time, the function of engine control systems shall be provided.

**16.1.5** For starting of the auxiliary engines provision shall be made for one air receiver with a capacity sufficient to provide 6 starts of the largest engine in ready to start condition.

Such an air receiver may be dispensed with, when the provisions is made to start the auxiliary engines from the air receivers of the main engines. In this case, the compressed air storage in each air receiver of the main engines shall be increased for a capacity sufficient to provide six starts of one auxiliary engine of the maximum output, and the air receivers shall be filled automatically and the requirements of 4.5, Part XV "Automation" shall be complied with.

**16.1.6** It is permitted that the starting air stored in one air receiver, or in a group of air receivers of the main engines according to 16.1.2, be used to feed the

tyfon whistle, as well as for domestic needs, provided the capacity of the air receiver is increased by an amount of air specified below for a special air receiver of the tyfon, or where the air receiver is fitted with automatic replenishing means or with alarms warning on a drop of pressure of not more than 0,49 MPa below the working pressure.

Where an air receiver is fitted especially for the tyfon, its capacity shall be determined so that the tyfon will be able to work continuously for 2 min, with hourly performance of compressor being not less than required to provide continuous operation of tyfon during 8 min.

If air from the air receiver of the tyfon is consumed also for other purposes, the capacity of the air receiver shall be increased as compared with that designed for tyfon only, with provision for automatic replenishing or signalling means which shall operate as soon as the amount of air in the air receiver is such as required for tyfon only.

In ships having a mark of automation the replenishing of air receivers shall proceed according to 4.5, Part XV "Automation".

**16.1.7** The air receivers of auxiliary engines indicated in 16.1.5 may be replenished from the main air receivers stated in 16.1.6, with any possibility of back flow being excluded.

**16.1.8** The starting devices of the emergency diesel generator shall comply with the requirements of 9.5, Part XI "Electrical Equipment".

Where a compressed air system is used as one of the means of starting the emergency diesel generator, the air receiver may be maintained from main or auxiliary starting air compressors through a non-return valve fitted in the emergency generator room, or from an electric compressor supplied from the emergency switchboard.

### 16.2 COMPRESSORS

**16.2.1** The number of the main air compressors shall be at least two. The total capacity of the main compressors shall be sufficient for the filling of the main air receivers during one hour for starting the main engines, beginning from the atmospheric pressure to the pressure required to carry out the number of starts and reverses referred to in 16.1.3 and 16.1.4. For ships, the main engines of which are started without a load, one of the main compressors may be attached on the engine. The capacity of individual main compressors shall be approximately

the same. The capacity of the independently driven compressors shall not be less than 50 per cent of that required of all the main compressors, but not less than the air consumption for the whistle according to 16.1.6.

**16.2.2** In cargo ships of less than 500 gross tonnage navigating in restricted areas **R3-RSN** and **R3** with reversible main engines, one independently driven compressor is permitted, whereas with main engines of a non-reversible type, one attached compressor is permitted. For the above ships having combined starting systems, one attached compressor may be installed. The capacity of the compressors shall be in accordance with the requirements of 16.2.1.

**16.2.3** In ships with the main and auxiliary engines arranged for compressed air starting, provision shall be made, in case of the ship blackout, for starting the main compressors during not more than one hour. For this purpose it is allowed to use a hand compressor or a hand operated diesel compressor to fill a separate air receiver, which capacity is sufficient for three starts of one of the diesel generators or one of the main compressors, where it is driven by an internal combustion engine.

A separate air receiver need not be installed where the diesel compressor or hand compressor is capable of filling the smallest of the air receivers specified in 16.1.5 during the aforesaid time period.

Where the motor of the compressor supplying one of the air receivers considered in this para can be energized by the emergency diesel generator, the above-mentioned provisions are not necessary. Where the above compressor is cooled with the motor pump, the motor of the pump shall be energized by emergency diesel generator.

This requirement is not applicable to cargo ships of less than 500 gross tonnage navigating in restricted areas **R2**, **R2-RSN**, **R2-RSN(4,5)**, **R3-RSN** and **R3**.

### 16.3 PIPING LAYING

**16.3.1** All pressure pipes from starting air compressors shall be laid directly to the starting air receivers, and all starting pipes from the air receivers to main or auxiliary engines shall be entirely separated from the compressor pressure pipe system.

**16.3.2** Each of the starting air receivers specified in 16.1 shall be capable of being filled from each main compressor specified in 16.2. Possibility of back flow shall be precluded (refer to 16.1.7).

**16.3.3** Non-return shut-off valves shall be installed on the discharge pipe of each compressor.

The manifold supplying starting air to each engine shall have a non-return valve placed before the cylinder starting valve.

The non-return valve may be omitted, if provision is made in the engine design for suitable devices protecting the manifold from the effects of an internal explosion (refer to 2.9.1, Part IX "Machinery").

**16.3.4** The temperature of air entering the receiver shall not exceed 90 °C. Where required, provision shall be made for coolers.

**16.3.5** The pipes shall be laid as straight as practicable with a slight slope in the direction of the master starting valve of the engine for water drainage.

**16.3.6** Suitable arrangements for draining the accumulations of oil and water shall be fitted on the pipes between compressors and air receivers, unless drain arrangements are fitted on the compressors.

**16.3.7** If the pressure relief valves or fuse plugs fitted on air receivers are arranged to discharge a compressed air outside engine rooms, the cross-sectional area of discharge pipes shall not be less than a two-fold cross-sectional area of the pressure relief valves or fuse plugs; appropriate arrangements for draining water from the pipes shall be provided.

## 17 FEED WATER SYSTEM

### 17.1 PUMPS

**17.1.1** Each main boiler and an essential auxiliary boiler or a group of boilers shall be provided with at least two independent feed pumps.

For auxiliary boilers, which are not intended for essential services, as well as for exhaust gas boilers so constructed that they can be left without water when heated by exhaust gas, one feed pump is sufficient.

For boilers with manual feed regulation the capacity of each pump shall not be less than 1,50 times the rated capacity of the boilers, and for boilers with automatic control systems, not less than 1,15 times their rated capacity.

Where several pumps are installed, their adopted capacity shall be such that in the event of damage to any of the pumps the total capacity of the rest of the pumps is not less than the capacity required in the foregoing for each pump.

The capacity of each feed pump of a straight-through boiler shall not be less than the rated capacity of the boiler.

**17.1.2** In the case of steam driven feed pumps, live steam shall be supplied to the line having connections from all the boilers fed by these pumps.

**17.1.3** The main and essential auxiliary boilers with forced circulation as well as waste heat boilers connected to exhaust gas systems of two-stroke diesels with inlet gas temperature of 270 °C and lower, shall be serviced by not less than two circulating pumps, one of which is a standby pump.

### 17.2 PIPING LAYING

**17.2.1** In case of open circuit feed system, the feed pumps and injectors shall be provided with suctions from the hot well and from the feed water storage tanks.

**17.2.2** The feed system of each main boiler and each auxiliary boiler for essential services shall be so constructed as to enable a boiler or a group of boilers to be fed by each pump through two separate feeding systems, i.e. the main and the auxiliary lines.

For non-essential auxiliary boilers, one feeding pipeline is sufficient.

Where a steam generation system consists of two or more adequately sized boilers, and the feed water for each of these boilers is supplied by a single feed water pipe, the level of redundancy for the piping of the feedwater system is considered sufficient.

**17.2.3** All structural measures shall be taken to prevent feed water being contaminated by oil and oily products.

**17.2.4** The main boilers and essential auxiliary boilers shall be provided with automatic devices for monitoring of feed water salinity.

**17.2.5** For the waste heat boilers with forced circulation, mentioned in 17.1.3, provision shall be made for the circulating water consumption, corresponding to at least 5-times design steam capacity to eliminate excessive heat emission in case of ignition of sediments. For this purpose a standby circulating pump of a waste heat boiler or another suitable pump may be used.

**17.2.6** Each exhaust gas heated economizer shall be provided with arrangements for water treatment, pre-heating and deaeration to ensure the quality of feed water compliance with the manufacturer's requirements.

### 17.3 TANKS

**17.3.1** Feed water tanks shall be separated from tanks containing oil fuel, lubricating oil and vegetable oil by cofferdams, the structural members of which shall comply with the requirements of Part II "Hull".

## 18 STEAM AND BLOW-OFF SYSTEMS

### 18.1 PIPING LAYING

**18.1.1** Where two or more boilers are connected to a common steam line, a non-return valve shall be fitted on the steam pipe of each boiler before connection to the common line.

These valves need not be fitted if the stop valves of the boilers are of non-return shut-off type.

**18.1.2** The blow-down and the scum valves of two or more boilers may be connected to a common discharge, provided a non-return stop-check valve is fitted on the blow-off pipe of each boiler before the connection to the discharge line.

**18.1.3** The machinery connected with the steam lines shall be relieved of the stresses caused by thermal expansion of pipes. It may be achieved by means of self-compensation (pipe bends) or by installation of thermal compensators in appropriate positions.

**18.1.4** In the steam lines supplying the machinery and arrangements designed for a lesser pressure than the boiler pressure, there shall be fitted reducing valves, and requirements of 1.4.4 shall be complied with.

**18.1.5** If provision is made for a steaming system for fuel and cargo oil tanks, each tank shall be fitted with non-return shut-off valves.

**18.1.6** The steam pipelines in the engine and boiler rooms shall be laid in the upper parts of these spaces, where practicable, in a position accessible for observation and servicing.

Laying of steam lines under the floor plates of engine and boiler rooms, with the exception of heating coils and boiler blow-off pipes, is not permitted.

Steam lines shall not be laid near the fuel oil tanks.

Steam lines shall not be laid in spaces used for carriage of flammable substances and in paint rooms.

Steam lines with working temperatures above 220 °C are not permitted to be laid in cargo pump rooms of tankers.

**18.1.7** While laying steam lines, the minimum distance from pipeline insulation shall be observed:  
to hull structures — 50 mm;  
to cable routing — 150 mm.

**18.1.8** Steam radiators shall be located at a distance of at least 50 mm from hull structures. If the hull structures are lined with a combustible material, the portions located against the heating elements shall be protected with heat insulation of non-combustible material. In the absence of heat insulation the heating elements shall be located at a distance of not less than 150 mm from the combustible lining.

### 18.2 BLOW-OFF ARRANGEMENTS OF STEAM LINES

**18.2.1** Pipelines conveying live steam shall have condensate drain arrangements to protect the machinery against water hammer.

**18.2.2** The open ends of the pipes for steam line blow-off shall be laid below the floor plates of the engine and boiler rooms (refer also to 5.3.7).

### 18.3 CALCULATION OF STEAM PIPES FOR THERMAL EXPANSION

**18.3.1** The calculation of steam pipes for thermal expansion shall be based on the methods generally adopted in structural mechanics for computing beam elements. On agreement with the Register, the calculation may be prepared on a computer or by means of a model method.

**18.3.2** The calculation of steam pipes for thermal expansion shall include a summary table of stresses and safety factors for all the pipe ranges dealt with in the calculation.

The steam pipes working under temperatures, which do not cause stress relaxation, shall, as a rule, be calculated for thermal expansion taking into account the initial prestressing, as well as prestressing in cold condition.

The steam pipes working under conditions of stress relaxation shall be calculated in cold condition for a 100 per cent prestressing considered as great as the displacements due to full thermal expansion (displacements of supports included), but with an opposite sign. Where a steam pipe in hot condition undergoes displacements, it shall be calculated in view of these displacements and, after that, for a 100 per cent prestressing in cold condition (displacements of supports included).

**Note.** The temperatures, which cause the pipes to relax are as follows:

350 °C and over — for carbon steel pipes;  
420 °C and over — for alloy steel pipes.

**18.3.3** In the calculation of thermal expansion the valves and fittings (elbows, T-joints, etc.) may be assumed rigid and need not be calculated for flexibility.

**18.3.4** The design stress in pipes shall be calculated depending on the pipe cross-sectional area, including the positive manufacturing tolerance for pipe wall thickness. The same sizes shall be used

for determining the stresses from displacements. As for the stresses caused by internal pressure, they shall be determined depending on pipe cross-sectional area, including the negative manufacturing tolerance for pipe wall thickness.

**18.3.5** For all types of butt joints of steam pipes welded with a back sealing run at the root, butt joints welded from both sides and made by automatic submerged arc welding, including joints welded on a removable backing ring, with surface dressing, the efficiency factor in the formula for stress calculation of piping may be assumed equal to a unity ( $\varphi=1$ ).

**18.3.6** In a calculation, the three components of reaction for a plane frame in general and the six components for a space frame shall be determined by force method, well known in structural mechanics beam system. In determining the components of reactions, the space frame of the pipe is reduced to three plane frames. To minimize the error due to reduction of the space frame to three plan frames, the axes of coordinates plotted for the pipe length under consideration shall be arranged parallel (or perpendicular) to the longest straight portion of the pipe and in a way that the curved portions be projected on the coordinate plane without distortion as far as is possible, or in form of straight lines.

**18.3.7** The flexibility coefficient  $k$  of the curved portion shall be determined by the formulae:

$$k = \frac{10 + 12\lambda^2}{1 + 12\lambda^2} \text{ for } \lambda \geq 0,4; \quad (18.3.7-1)$$

and

$$k = 1,65/\lambda \text{ for } 0,2 \leq \lambda < 0,4 \quad (18.3.7-2)$$

where  $\lambda = sR/r^2$  — geometrical coefficient of bent pipe;  
 $s$  = wall thickness of straight pipe, mm;  
 $R$  = bending radius of the curved portion, mm;  
 $r$  = average radius of cross-sectional area of a straight pipe, mm.

**18.3.8** In calculating the steam pipes for thermal expansion, the maximum stresses to be determined are as follows:

resultant stress for a straight pipe conveying hot steam under working pressure, as well as for cold pipe not subjected to internal pressure;

total local stress acting on the inside of a bent pipe conveying hot steam under working pressure, as well as in bent pipe when cold and not subjected to internal pressure.

Bent pipes with  $\lambda \geq 1,44$  may be regarded as straight, when determining the resultant stress, and need not be calculated for total local stress.

When the assembled steam pipeline is subjected to a hydraulic test on board ship, the resultant stresses shall be shown also for a cold pipeline at they hydraulic test pressure.

**18.3.9** The resultant stress  $\sigma_c$  in a straight pipe when exposed to internal pressure and to the bending and twisting moments shall be determined by the formula

$$\sigma_{res} = \sqrt{\sigma_1^2 + \sigma_2^2 + \sigma_3^2 - \sigma_1\sigma_2 - \sigma_1\sigma_3 - \sigma_2\sigma_3 + 3\tau^2} \quad (18.3.9)$$

where  $\sigma_1$  = total normal stress from bending and internal pressure, MPa;  
 $\sigma_2$  = circumferential stress due to internal pressure, MPa;  
 $\sigma_3$  = radial stress due to internal pressure, MPa;  
 $\tau$  = shearing stress, MPa.

**18.3.10** The total stress acting on the inside of a bent pipe shall be determined in all cases of bending (plane, perpendicular to curvature plane of a bent pipe, and tangential) as a sum of bending stresses and circumferential stress from internal pressure.

**18.3.11** Safety factors, relating to the yield point and average stress producing rupture, which shall be used in the calculation of the resultant stress and the total local stress, are as follows:

- 1,2 — for plane frame;
- 1,5 — for space frame.

## 19 CONDENSER INSTALLATIONS

### 19.1 GENERAL

**19.1.1** Each main turbine set shall be fitted with an independent condenser installation ensuring a stable vacuum under all rated operating conditions.

The auxiliary turbines may have a common condenser installation. In running conditions, waste steam from the auxiliary turbo-generators may be discharged into the main condenser or into the stages of the main turbine set.

### 19.2 PUMPS

**19.2.1** The main condenser shall be serviced by two circulating cooling pumps, one of which is a standby pump.

The capacity of the standby pump shall not be less than 30 per cent of rated quantity of circulating water for all consumers.

Any pump of sufficient capacity may be used as a standby pump (refer to 15.1.4).

In twin-screw ships it is allowed to use one standby circulating pump for both turbine sets.

Where, for servicing the main condenser, provision is made for simultaneous operation of both pumps, the capacity of each pump shall make not less than 50 per cent of the rated quantity of circulating water for all the consumers. No standby circulating pump is required in this case.

**19.2.2** Where the auxiliary condenser is common for all the turbo-generators, it shall be serviced by two circulating cooling pumps, one of which is a standby pump.

Any pump of sufficient capacity may be used as a standby pump.

**19.2.3** A sea inlet scoop arrangement of water cooling may be permitted if a circulating pump is fitted, which has a capacity sufficient to ensure the full astern speed condition. The standby circulating pump shall meet the requirements of 19.2.1.

**19.2.4** The condensate system of a steam turbine installation shall be serviced by two condensate pumps. The capacity of each pump shall exceed by not less than 25 per cent the maximum design amount of steam and condensate entering the condenser. In the installations with two main condensers arranged in the same engine room, the standby condensate pump may be common for both condensers.

### 19.3 PIPING LAYING

**19.3.1** The laying of pipes and their connections shall comply with the requirements of 15.2.

**19.3.2** The condensate collector, discharge pipe and condensate pump shall be so arranged as to preclude flooding of the lower rows of pipes and to ensure the required positive pressure and smooth delivery of condensate to the pump.

Provision shall be made for a handhole for cleaning the condensate collector.

**19.3.3** The nozzles of the ejectors of the condenser installations shall be protected against damage and clogging, for which purpose a metal screen shall be fitted in the steam pipe.

### 19.4 INSTRUMENTATION

**19.4.1** The condenser installation shall be fitted with gauges and alarms, including:

- .1 a condensate level indicator for the condenser;
- .2 vacuum and pressure gauges for the condenser and ejector coolers;
- .3 a pressure gauge in the steam line to ejector;
- .4 thermometers for the cooling water discharge pipes of the condenser and ejector coolers;
- .5 salinometers with visual and audible alarms indicating condensate salinity.

## 20 THERMAL LIQUID SYSTEMS

### 20.1 DEFINITIONS

**20.1.1** Thermal liquid boiler is the heat-exchange apparatus for heating a thermal liquid up to the required temperature using the energy of fuel oil burnt in it, of an engine exhaust gases or electric power.

Thermal liquid heater is the heat-exchange apparatus for heating a thermal liquid with steam, water electric power or thermal liquid of another circuit.

Working pressure in the thermal liquid system is the highest pressure that may arise in any part of the system in operation.

Thermal liquid system is the system, in which a thermal liquid circulates in a liquid phase.

Thermal liquid temperature is the temperature measured in the centre of a pipeline cross section.

### 20.2 REQUIREMENTS FOR THERMAL LIQUID

**20.2.1** A thermal liquid may be used within the range of working temperatures specified by a manufacturer. In this case, the maximum working temperature of the thermal liquid shall not be less than 50 °C below the temperature of boiling beginning at an atmospheric pressure.

**20.2.2** In thermal liquid heaters, the heating medium temperature shall be below the temperature of boiling beginning of the thermal liquid being heated.

### 20.3 THERMAL LIQUID CIRCULATION SYSTEM

**20.3.1** In order to ensure the thermal liquid circulation in the circuits of all boilers as well as the heaters for essential services, the system shall be provided with two circulating pumps.

For the systems for non-essential services, in which heaters are used for heating the thermal liquid, one pump may be provided.

**20.3.2** Manometers shall be fitted on the side of the thermal liquid outlet from pumps.

**20.3.3** Engines of thermal liquid circulating pumps shall be fitted with disconnectors meeting the requirements of 5.7.1, Part XI "Electrical Equipment".

**20.3.4** The circulating pumps shall be locally and remotely controlled.

**20.3.5** In case of disconnection of all services, circulation of the thermal liquid through the boilers and heaters shall automatically continue for a time necessary for eliminating the residual heat release.

If the temperature of the exit gas or thermal liquid cannot exceed the boiling temperature of the thermal liquid at atmospheric pressure, this requirement may be dispensed with.

### 20.4 EXPANSION TANK

**20.4.1** A thermal liquid system shall be provided with an expansion tank placed, as a rule, at the highest point of the system.

**20.4.2** An expansion tank shall be fitted with a liquid level indicator meeting the requirements of 10.4.

The lowest permissible liquid level shall be marked on the level indicator.

**20.4.3** The expansion tank of an open system shall be equipped with an air pipe, and also with an overflow pipe laid to a drain tank or storage tank if the former is lacking.

**20.4.4** Provision shall be made for the alarm, which indicates when the lowest and highest thermal liquid levels are reached in the tank. When the thermal liquid level is lower than the lowest permissible level, heating in boilers shall be automatically discontinued and circulating pumps shall be stopped.

**20.4.5** The expansion tank of a closed system shall be equipped with a manometer and safety valve. The safety valve outlet pipe shall be connected to a drain or storage tank. The opportunity of the closed system operation in the mode of the open system shall be provided.

**20.4.6** The expansion tanks having thermal insulation shall be fitted with thermometers to monitor the thermal liquid temperature.

**20.4.7** The expansion tank capacity within the level indicator range measured from the lowest permissible level mark up to the overflow pipe top shall not less than by 30 per cent exceed the design increased volume of the thermal liquid in the system during operation. The total quantity of the thermal liquid in the equipment and piping when filled up to the minimum working level in the expansion tank shall be taken as the initial volume.

**20.4.8** The expansion tank shall be fitted with a valve locally and remotely controlled outside the space, in which the tank is located for an emergency discharge of the thermal liquid.

## 20.5 STORAGE AND DRAIN TANKS

**20.5.1** The system shall be provided with a storage and a drain tanks. The storage tank capacity shall be at least 40 per cent of the system capacity. Depending on the system purpose and the ship navigation area, the storage tank capacity may be reduced.

**20.5.2** The drain tank capacity shall be sufficient for draining the thermal liquid from the largest disconnectible section. For emergency draining of the thermal liquid from boilers (refer to 3.5, Part X "Boilers, Heat Exchangers and Pressure Vessels") the tank shall be provided with capacity sufficient for draining into it of the thermal liquid from the whole system.

**20.5.3** The common tank for storage of the thermal liquid supply and of its drain from a system may be used. In this case, the capacity of that tank shall be adequate for the simultaneous storage of the thermal liquid supply and drain. The tank location shall provide an opportunity to drain into it the complete thermal liquid.

## 20.6 PIPING AND VALVES

**20.6.1** Thermal liquid piping laying shall meet the requirements of 13.2 and Section 5.

**20.6.2** Bellows-type valves shall be used in piping containing the pressure thermal liquid.

**20.6.3** The use of copper and its alloys is not permitted for the system components contacting the thermal liquid.

**20.6.4** Seals and gaskets shall be of materials resistant to thermal liquids.

**20.6.5** Threaded connections shall not be used for thermal liquid pipelines.

**20.6.6** Steel pipe wall thickness shall meet the requirements of 2.3.1. In this case, the design pressure shall be assumed not less than 1,4 MPa.

**20.6.7** The thermal liquid arrangement design shall provide for filling the system, filling up the expansion tank, and also the thermal liquid pumping.

**20.6.8** An opportunity of thermal liquid sampling shall be provided in each independent circulation circuit.

**20.6.9** The system shall be designed so as to prevent deterioration of the thermal liquid quality due to local overheating or air contact.

**20.6.10** The system shall be provided with an effective arrangement for trapping and removal of emitting vapours and gases. The operation of this arrangement shall not result in circulation and heating of the thermal liquid in an expansion tank above 50 °C.

**20.6.11** An opportunity of controlling of at least thermal liquid flow rate and temperature by means of

a manual control from a local station shall be provided in the system.

**20.6.12** The company nameplate in the conspicuous place in the immediate vicinity of circulating pumps shall be provided. It shall contain the following main information on the system:

manufacturer;

year of mounting;

maximum design working temperature of the thermal liquid;

system capacity;

maximum permissible working pressure.

**20.6.13** The tanks containing the thermal liquid in which water may accumulate shall be fitted with drain cocks to remove sediment.

## 20.7 AIR PIPES AND SOUNDING ARRANGEMENTS

**20.7.1** Air pipes of thermal liquid tanks shall meet the requirements of 10.1, applicable to the fuel oil and lubricating oil tanks.

**20.7.2** Air pipes of thermal liquid tanks shall be carried to open decks.

**20.7.3** If there are ignition hazards in the premise, the sounding arrangements of thermal liquid tank shall comply with requirements of 10.4.2 and 10.4.4.

## 20.8 ARRANGEMENTS FOR COLLECTING OF THERMAL LIQUID LEAKAGES

**20.8.1** Arrangements for collecting of thermal liquid leakages shall meet the requirements of 13.5.

**20.8.2** Provision shall be made for the arrangements on the gas side in waste-heat boilers and on exhaust gas piping, which prevent an ingress of the leaking thermal liquid into an engine, and also of the water used for fire extinguishing or boiler washing.

## 20.9 THERMAL LIQUID BOILERS

**20.9.1** The requirements of 3.5, Part X "Boilers, Heat Exchangers and Pressure Vessels" apply to thermal liquid boilers and heaters.

## 20.10 INSULATION

**20.10.1** The insulation of the system piping and equipment shall meet the requirements in 4.6, Part VII "Machinery Installations".

**20.11 HEATING OF LIQUID CARGOES**

**20.11.1** Where a thermal liquid is used for liquid cargoes or other liquid products heating, it shall be compatible with heated products when in contact due to leakages of heater coils or pipes. The use of a thermal liquid, which may enter into a hazardous reaction with a heated product, is not permitted.

**20.11.2** The use of thermal liquid systems for heating liquid cargoes with a flash point below 60 °C is permitted only if an independent intermediate system located within a cargo area is fitted. However, such a system may be unnecessary if the following conditions are observed:

**.1** the system is designed so that with a circulating pump switched off the excessive pressure in coils is at least 0,03 MPa above the static cargo head;

**.2** means for detection of flammable cargo vapours in the thermal liquid system expansion tank are provided;

**.3** valves of separate heating coils are provided with locking arrangements, which ensure that the coils are permanently under the above static pressure.

**20.12 THERMAL LIQUID SYSTEM PIPING TESTING**

**20.12.1** Thermal liquid systems piping and their components shall be tested according to the requirements of 21.2 like fuel oil pipelines with a design pressure over 0,35 MPa.

## 21 TESTS

### 21.1 HYDRAULIC TESTS OF VALVES

**21.1.1** The valves intended for Class I and Class II piping shall be subjected to a hydraulic test by the pressure indicated in 1.3.1, Part IX "Machinery".

**21.1.2** The valves intended to work under a design pressure of 0,098 MPa and less, as well as in vacuum conditions shall be tested by a pressure not less than 0,196 MPa.

**21.1.3** Valves, cocks and other fittings intended to be fitted on the ship side below the loadline shall be tested by hydraulic pressure not less than 0,5 MPa.

**21.1.4** After assembly, the valves shall be checked for leakage by a hydraulic pressure equal to the design pressure.

### 21.2 HYDRAULIC TESTS OF PIPING

**21.2.1** All Class I and Class II pipes, as well as steam, feed, compressed air and fuel oil pipes with design pressure over 0,35 MPa irrespective of their class, shall be tested by hydraulic pressure in the presence of a surveyor to the Register after completion of manufacture and before insulating and coating, by a test pressure, in MPa:

$$p_{test} = 1,5p \quad (21.2.1-1)$$

where  $p$  = design pressure (refer to 2.3.1), MPa.

The test pressure for steel pipes, MPa, intended for design temperatures over 300 °C, shall be determined from the following formula, but it need not exceed  $2p$ :

$$p_{test} = 1,5 \frac{\sigma_{100}}{\sigma_t} p \quad (21.2.1-2)$$

where  $\sigma_{100}$  = permissible stress at 100 °C;

$\sigma_t$  = permissible stress at design temperature.

In case where during the test excessive stress arises the value of test pressure, as obtained from Formula (21.2.1-2), may be reduced to  $1,5p$  on agreement with the Register.

In no case shall be stresses arising during the test exceed 0,9 of the yield point at the temperature of testing.

**21.2.2** Pressure testing of small bore pipes (less than 15 mm) of any class may be omitted at discretion of the Register, depending on the application of these pipes. When assembled piping is exposed to hydraulic strength tests at  $1,5p$ , it is allowed not to perform preliminary strength test of pipes listed in 21.2.1.

**21.2.3** All the piping systems shall be checked for tightness in operating conditions in the presence of a surveyor to the Register, except that particular testing is required for the following piping:

.1 heating coils in tanks and liquid or gas fuel lines shall be tested by  $1,5p$ , but not less than 0,4 MPa;

.2 liquefied gas pipelines shall be leak tested in compliance with 13.14.17.

**21.2.4** Where, for technical reasons, the hydraulic test of the entire pipeline cannot be carried out, proposals shall be submitted to the Register for testing of separate pipe lengths, in particular, the end joints.

**21.2.5** In the case where hydraulic tests of an assembled piping system are carried out on board, testing of piping for tightness and strength may be combined.

**21.2.6** Liquefied gas pipe lines from containers to reducing valves shall be tested in accordance with 3.14.17.

**21.2.7** On agreement with the Register the pipes tested by hydraulic pressure after completion of manufacture in compliance with 21.2.1, all the piping systems (with the exception of steam, feed, boiler blow-off pipes, freon and ammonia, as well as pipelines with welded joints) intended to work under pressure up to 5 MPa are allowed to be tested with compressed air instead of testing for tightness (refer to 21.2.3).

The value of test pressure with compressed air shall be  $P_{test} = 0,1P$ , but not less than 0,2 MPa.

For pipes intended to work in vacuum conditions the test pressure with compressed air shall be 0,2 Pa.

Pipes of fuel oil that work at pressure of up to 0,6 MPa and that have welded joints shall be checked by test pressure with compressed air accepted in compliance with 21.2.1 during the time necessary to check the air leakage but not less than 10 min.

### 21.3 TESTING OF DEVICES TO PREVENT THE PASSAGE OF FLAME INTO CARGO TANKS IN OIL TANKERS

**21.3.1** Prior to assembly on board, flame arresters, flame screens, high velocity vents and pressure/vacuum valves along with protective devices against atmospheric precipitation shall be tested in accordance with the IMO procedure to be found in MSC/Circ. 677.

#### 21.4 TESTING OF AIR PIPE AUTOMATIC CLOSING DEVICES

**21.4.1** Each type and size of air pipe automatic closing device shall be surveyed and shall undergo the following tests:

**.1** determination of the flow characteristics.

Measuring of the pressure drop versus rate of volume flow shall be carried out using water and with any intended flame or insect screens in place;

**.2** tightness test during immersion/emerging in water.

An automatic closing device shall be subjected to a series of tightness test involving not less than two immersion cycles under the following conditions:

the automatic closing device shall be submerged slightly below the water surface at a velocity of approximately 4 m/min and then returned to the original position immediately. The quantity of leakage shall be recorded;

the automatic closing device shall be submerged to a point slightly below the surface of the water. The submerging velocity shall be approximately 8 m/min and the device shall remain submerged for not less than 5 min.

Each of the above tightness tests shall be carried out in the normal position as well as at an inclination of 40° under the strictest conditions for the device. In cases where such strictest conditions are not clear, tests shall be carried out at an inclination of 40 degrees with the device opening facing in three different directions: upward, downward, sideways (left or right).

The maximum allowable leakage per cycle shall not exceed 2 ml/mm of nominal diameter of inlet pipe;

**.3** discharge / reverse flow test.

The air pipe head shall allow the passage of air to prevent excessive vacuum developing in the tank. A reverse flow test shall be performed. A vacuum pump or another suitable device shall be connected to the opening of the air pipe leading to the tank. The flow velocity shall be applied gradually at a constant rate until the float gets sucked and blocks the flow. The velocity at the point of blocking shall be recorded. 80 per cent of the value recorded will be stated in the certificate.

**21.4.2** Impact and compression loading tests shall be carried out on non-metallic ball type floats by the manufacturer bearing in mind the requirements of Table 21.4.2, as follows:

Table 21.4.2

Test condition	Test temperature, °C		
	-25	+20	+85
Dry	+	+	+
After immersing in water <sup>1</sup>	+	+	+
After immersing in fuel oil <sup>1</sup>	—	+	—
Symbols: "+" where the test shall be conducted; "—" where the test shall not be conducted.			
<sup>1</sup> Immersing in water and fuel oil shall be for at least 48 h.			

**.1** impact test shall be conducted on a pendulum type testing machine. The floats shall be subjected to 5 impacts of 2,5 N/m each and shall not suffer permanent deformation, cracking or surface deterioration at this impact loading. Subsequently the floats shall be subjected to 5 impacts of 25 N/m each. At this impact energy level some localized surface damage at the impact point may occur, but no permanent deformation or cracking of the float shall appear;

**.2** compression test shall be conducted with the floats mounted on a supporting ring of a diameter and bearing area corresponding to those of the float seating with which it is intended that the float shall be used. Loads shall be applied through a concave cap of the same internal radius as the test float. A load of 350 kg shall be applied over one minute and maintained for 60 min. The deflection shall be measured at intervals of 10 min after attachment of the full load. The record of deflection against time shall show no continuing increase in deflection and, after release of the load, there shall be no permanent deflection;

**.3** testing of metallic ball type floats shall be conducted in accordance with 21.4.2.1.

#### 21.5 TESTING OF PLASTIC PIPES

**21.5.1** Plastic pipes shall be tested taking into consideration the requirements of 6.8, Part XIII "Materials", and where necessary, their fire resistance shall be confirmed and flame spread tested in accordance with 3.3.1 and 3.3.2.1 of the present Part.

**21.5.2** The quality of joints shall be tested taking into consideration the requirements of 3.5.2, and piping as assembled on board shall be tested in accordance with the requirements of 3.8.



**Российский морской регистр судоходства**  
**Правила классификации и постройки морских судов**  
**Часть VIII**  
**Системы и трубопроводы**

**Russian Maritime Register of Shipping**  
**Rules for the Classification and Construction of Sea-Going Ships**  
**Part VIII**  
**Systems and Piping**

The edition is prepared  
by Russian Maritime Register of Shipping  
8, Dvortsovaya Naberezhnaya,  
191186, St. Petersburg,  
Russian Federation  
[www.rs-class.org/en/](http://www.rs-class.org/en/)